CBSE CLASS XII

REFERENCE MATERIAL

<https://www.cbse.gov>

Dear Students,

Your Success Is Our Priority!

As you start on the final leg of your educational journey with us, we want to express our sincere commitment to your success. Your upcoming CBSE board exams mark a significant milestone in your academic career, and ICAD School of Learning is here to support you every step of the way. At ICAD School of Learning, we understand the importance of these board exams in shaping your future. This comprehensive reference material has been meticulously crafted to help you excel in your CBSE board exams.

What's Inside:

- The Latest Syllabus: Stay aligned with the CBSE curriculum, ensuring you cover all essential topics.
- Sample Papers: Practice makes perfect! Put your skills to the test with official sample papers released by CBSE.
- Solutions with Marking Scheme: Learn not only how to answer questions but also how to maximize your scores.
- Question Banks: Practice questions of Maths and Chemistry from the CBSE website

As educators, our greatest satisfaction comes from witnessing your growth and accomplishments. We have every confidence that you have the potential to achieve remarkable results, and ICAD School of Learning is here to support you at every turn. We wish you all the best as you prepare for your CBSE board exams. Remember, your hard work, dedication, and belief in yourself will carry you through any challenge. You've got this!

Together, Let's Achieve Excellence!

We are proud to be a part of your educational journey and look forward to celebrating your triumphs.

Best wishes,

ICAD School of Learning.

CONTENTS

	Page No.
1. MATHEMATICS SYLLABUS	1-7
2. SAMPLE QUESTION PAPER	8-15
3. MARKING SCHEME AND SOLUTION	16-34
4. QUESTION BANK	35-80
5. PHYSICS SYLLABUS	81-93
6. SAMPLE QUESTION PAPER	94-103
7. MARKING SCHEME AND SOLUTION	104-113
7. CHEMISTRY SYLLABUS	114-120
8. SAMPLE QUESTION PAPER	121-128
9. MARKING SCHEME AND SOLUTION	129-135
10. QUESTION BANK	136-162
11. BIOLOGY SYLLABUS	163-168
12. SAMPLE QUESTION PAPER	169-176
13. MARKING SCHEME AND SOLUTION	177-187

CLASS-XII
(2023-24)

One Paper

Max Marks: 80

No.	Units	No. of Periods	Marks
I.	Relations and Functions	30	08
II.	Algebra	50	10
III.	Calculus	80	35
IV.	Vectors and Three - Dimensional Geometry	30	14
V.	Linear Programming	20	05
VI.	Probability	30	08
	Total	240	80
	Internal Assessment		20

Unit-I: Relations and Functions

1. Relations and Functions **15 Periods**

Types of relations: reflexive, symmetric, transitive and equivalence relations. One to one and onto functions.

2. Inverse Trigonometric Functions **15 Periods**

Definition, range, domain, principal value branch. Graphs of inverse trigonometric functions.

Unit-II: Algebra

1. Matrices **25 Periods**

Concept, notation, order, equality, types of matrices, zero and identity matrix, transpose of a matrix, symmetric and skew symmetric matrices. Operations on matrices: Addition and multiplication and multiplication with a scalar. Simple properties of addition, multiplication and scalar multiplication. Non-commutativity of multiplication of matrices and existence of non-zero matrices whose product is the zero matrix (restrict to square matrices of order 2). Invertible matrices and proof of the uniqueness of inverse, if it exists; (Here all matrices will have real entries).

2. Determinants **25 Periods**

Determinant of a square matrix (up to 3 x 3 matrices), minors, co-factors and applications of determinants in finding the area of a triangle. Adjoint and inverse of a square matrix. Consistency, inconsistency and number of solutions of system of linear equations by examples, solving system of linear equations in two or three variables (having unique solution) using inverse of a matrix.

Unit-III: Calculus

1. Continuity and Differentiability

20 Periods

Continuity and differentiability, chain rule, derivative of inverse trigonometric functions, like $\sin^{-1} x$, $\cos^{-1} x$ and $\tan^{-1} x$, derivative of implicit functions. Concept of exponential and logarithmic functions.

Derivatives of logarithmic and exponential functions. Logarithmic differentiation, derivative of functions expressed in parametric forms. Second order derivatives.

2. Applications of Derivatives

10 Periods

Applications of derivatives: rate of change of quantities, increasing/decreasing functions, maxima and minima (first derivative test motivated geometrically and second derivative test given as a provable tool). Simple problems (that illustrate basic principles and understanding of the subject as well as real-life situations).

3. Integrals

20 Periods

Integration as inverse process of differentiation. Integration of a variety of functions by substitution, by partial fractions and by parts, Evaluation of simple integrals of the following types and problems based on them.

$$\int \frac{dx}{x^2 \pm a^2}, \int \frac{dx}{\sqrt{x^2 \pm a^2}}, \int \frac{dx}{\sqrt{a^2 - x^2}}, \int \frac{dx}{ax^2 + bx + c}, \int \frac{dx}{\sqrt{ax^2 + bx + c}}$$

$$\int \frac{px + q}{ax^2 + bx + c} dx, \int \frac{px + q}{\sqrt{ax^2 + bx + c}} dx, \int \sqrt{a^2 \pm x^2} dx, \int \sqrt{x^2 - a^2} dx$$

$$\int \sqrt{ax^2 + bx + c} dx,$$

Fundamental Theorem of Calculus (without proof). Basic properties of definite integrals and evaluation of definite integrals.

4. Applications of the Integrals

15 Periods

Applications in finding the area under simple curves, especially lines, circles/ parabolas/ellipses (in standard form only)

5. Differential Equations

15 Periods

Definition, order and degree, general and particular solutions of a differential equation. Solution of differential equations by method of separation of variables, solutions of homogeneous differential equations of first order and first degree. Solutions of linear differential equation of the type:

$$\frac{dy}{dx} + py = q, \text{ where } p \text{ and } q \text{ are functions of } x \text{ or constants.}$$
$$\frac{dx}{dy} + px = q, \text{ where } p \text{ and } q \text{ are functions of } y \text{ or constants.}$$

Unit-IV: Vectors and Three-Dimensional Geometry

1. Vectors

15 Periods

Vectors and scalars, magnitude and direction of a vector. Direction cosines and direction ratios of a vector. Types of vectors (equal, unit, zero, parallel and collinear vectors), position vector of a point, negative of a vector, components of a vector, addition of vectors, multiplication of a vector by a scalar, position vector of a point dividing a line segment in a given ratio. Definition, Geometrical Interpretation, properties and application of scalar (dot) product of vectors, vector (cross) product of vectors.

2. Three - dimensional Geometry

15 Periods

Direction cosines and direction ratios of a line joining two points. Cartesian equation and vector equation of a line, skew lines, shortest distance between two lines. Angle between two lines.

Unit-V: Linear Programming

1. Linear Programming

20 Periods

Introduction, related terminology such as constraints, objective function, optimization, graphical method of solution for problems in two variables, feasible and infeasible regions (bounded or unbounded), feasible and infeasible solutions, optimal feasible solutions (up to three non-trivial constraints).

Unit-VI: Probability

1. Probability

30 Periods

Conditional probability, multiplication theorem on probability, independent events, total probability, Bayes' theorem, Random variable and its probability distribution, mean of random variable.

MATHEMATICS (Code No. - 041)
QUESTION PAPER DESIGN CLASS - XII
(2023-24)

Time: 3 hours

Max. Marks: 80

S. No.	Typology of Questions	Total Marks	% Weightage
1	<p>Remembering: Exhibit memory of previously learned material by recalling facts, terms, basic concepts, and answers.</p> <p>Understanding: Demonstrate understanding of facts and ideas by organizing, comparing, translating, interpreting, giving descriptions, and stating main ideas</p>	44	55
2	<p>Applying: Solve problems to new situations by applying acquired knowledge, facts, techniques and rules in a different way.</p>	20	25
3	<p>Analysing : Examine and break information into parts by identifying motives or causes. Make inferences and find evidence to support generalizations</p> <p>Evaluating: Present and defend opinions by making judgments about information, validity of ideas, or quality of work based on a set of criteria.</p> <p>Creating: Compile information together in a different way by combining elements in a new pattern or proposing alternative solutions</p>	16	20
	Total	80	100

- No chapter wise weightage. Care to be taken to cover all the chapters*
- Suitable internal variations may be made for generating various templates keeping the overall weightage to different form of questions and typology of questions same.*

Choice(s):

There will be no overall choice in the question paper.

However, 33% internal choices will be given in all the sections

INTERNAL ASSESSMENT	20 MARKS
Periodic Tests (Best 2 out of 3 tests conducted)	10 Marks
Mathematics Activities	10 Marks

Note: For activities NCERT Lab Manual may be referred.

Conduct of Periodic Tests:

Periodic Test is a Pen and Paper assessment which is to be conducted by the respective subject teacher. The format of periodic test must have questions items with a balance mix, such as, very short answer (VSA), short answer (SA) and long answer (LA) to effectively assess the knowledge, understanding, application, skills, analysis, evaluation and synthesis. Depending on the nature of subject, the subject teacher will have the liberty of incorporating any other types of questions too. The modalities of the PT are as follows:

- a) **Mode:** The periodic test is to be taken in the form of pen-paper test.
- b) **Schedule:** In the entire Academic Year, three Periodic Tests in each subject may be conducted as follows:

Test	Pre Mid-term (PT-I)	Mid-Term (PT-II)	Post Mid-Term (PT-III)
Tentative Month	July-August	November	December-January

This is only a suggestive schedule and schools may conduct periodic tests as per their convenience. The winter bound schools would develop their own schedule with similar time gaps between two consecutive tests.

- c) **Average of Marks:** Once schools complete the conduct of all the three periodic tests, they will convert the weightage of each of the three tests into ten marks each for identifying best two tests. The best two will be taken into consideration and the average of the two shall be taken as the final marks for PT.
- d) The school will ensure simple documentation to keep a record of performance as suggested in detail circular no.Acad-05/2017.
- e) **Sharing of Feedback/Performance:** The students' achievement in each test must be shared with the students and their parents to give them an overview of the level of learning that has taken place during different periods. Feedback will help parents formulate interventions (conducive ambience, support materials, motivation and morale-boosting) to further enhance learning. A teacher, while sharing the feedback with student or parent, should be empathetic, non- judgmental and motivating. It is recommended that the teacher share best examples/performances of IA with the class to motivate all learners.

Assessment of Activity Work:

Throughout the year any 10 activities shall be performed by the student from the activities given in the NCERT Laboratory Manual for the respective class (XI or XII) which is available on the link: <http://www.ncert.nic.in/exemplar/labmanuals.html> a record of the same may be kept by the student. An year end test on the activity may be conducted

The weightage are as under:

- The activities performed by the student throughout the year and record keeping : 5 marks
- Assessment of the activity performed during the year end test: 3 marks
- Viva-voce: 2 marks

Prescribed Books:

- 1) Mathematics Textbook for Class XI, NCERT Publications
- 2) Mathematics Part I - Textbook for Class XII, NCERT Publication
- 3) Mathematics Part II - Textbook for Class XII, NCERT Publication
- 4) Mathematics Exemplar Problem for Class XI, Published by NCERT
- 5) Mathematics Exemplar Problem for Class XII, Published by NCERT
- 6) Mathematics Lab Manual class XI, published by NCERT
- 7) Mathematics Lab Manual class XII, published by NCERT

SAMPLE QUESTION PAPER

Class:-XII

Session 2023-24

Mathematics (Code-041)

Time: 3 hours

Maximum marks: 80

General Instructions:

1. This Question paper contains - five sections **A, B, C, D** and **E**. Each section is compulsory. However, there are internal choices in some questions.
 2. **Section A** has 18 MCQ's and 02 Assertion-Reason based questions of 1 mark each.
 3. **Section B** has 5 Very Short Answer (VSA)-type questions of 2 marks each.
 4. **Section C** has 6 Short Answer (SA)-type questions of 3 marks each.
 5. **Section D** has 4 Long Answer (LA)-type questions of 5 marks each.
 6. **Section E** has 3 source based/case based/passage based/integrated units of assessment of 4 marks each with sub-parts.
-

Section –A

(Multiple Choice Questions)

Each question carries 1 mark

Q1. If $A = [a_{ij}]$ is a square matrix of order 2 such that $a_{ij} = \begin{cases} 1, & \text{when } i \neq j \\ 0, & \text{when } i = j \end{cases}$, then A^2 is

- (a) $\begin{bmatrix} 1 & 0 \\ 1 & 0 \end{bmatrix}_{2 \times 2}$ (b) $\begin{bmatrix} 1 & 1 \\ 0 & 0 \end{bmatrix}_{2 \times 2}$ (c) $\begin{bmatrix} 1 & 1 \\ 1 & 0 \end{bmatrix}_{2 \times 2}$ (d) $\begin{bmatrix} 1 & 0 \\ 0 & 1 \end{bmatrix}_{2 \times 2}$

Q2. If A and B are invertible square matrices of the same order, then which of the following is not correct?

- (a) $|\mathbf{AB}^{-1}| = \frac{|\mathbf{A}|}{|\mathbf{B}|}$ (b) $|(\mathbf{AB})^{-1}| = \frac{1}{|\mathbf{A}| |\mathbf{B}|}$
- (c) $(\mathbf{AB})^{-1} = \mathbf{B}^{-1} \mathbf{A}^{-1}$ (d) $(\mathbf{A} + \mathbf{B})^{-1} = \mathbf{B}^{-1} + \mathbf{A}^{-1}$

Q3. If the area of the triangle with vertices $(-3, 0)$, $(3, 0)$ and $(0, k)$ is 9 sq units, then the value/s of k will be

- (a) 9 (b) ± 3 (c) -9 (d) 6

Q4. If $f(x) = \begin{cases} kx, & \text{if } x < 0 \\ |x|, & \text{if } x \geq 0 \end{cases}$ is continuous at $x = 0$, then the value of k is

- (a) -3 (b) 0 (c) 3 (d) any real number

Q5. The lines $\vec{r} = \hat{i} + \hat{j} - \hat{k} + \lambda(2\hat{i} + 3\hat{j} - 6\hat{k})$ and $\vec{r} = 2\hat{i} - \hat{j} - \hat{k} + \mu(6\hat{i} + 9\hat{j} - 18\hat{k})$; (where λ & μ are scalars) are

- (a) coincident (b) skew (c) intersecting (d) parallel

Q6. The degree of the differential equation $\left[1 + \left(\frac{dy}{dx}\right)^2\right]^3 = \left(\frac{d^2y}{dx^2}\right)^2$ is

- (a) 4 (b) $\frac{3}{2}$ (c) 2 (d) Not defined

Q7. The corner points of the bounded feasible region determined by a system of linear constraints are $(0,3), (1,1)$ and $(3,0)$. Let $Z = px + qy$, where $p, q > 0$. The condition on p and q so that the minimum of Z occurs at $(3,0)$ and $(1,1)$ is

- (a) $p = 2q$ (b) $p = \frac{q}{2}$ (c) $p = 3q$ (d) $p = q$

Q8. $ABCD$ is a rhombus whose diagonals intersect at E . Then $\overline{EA} + \overline{EB} + \overline{EC} + \overline{ED}$ equals to

- (a) $\vec{0}$ (b) \overline{AD} (c) $2\overline{BD}$ (d) $2\overline{AD}$

Q9. For any integer n , the value of $\int_{-\pi}^{\pi} e^{\cos^2 x} \sin^3(2n+1)x \, dx$ is

- (a) -1 (b) 0 (c) 1 (d) 2

Q10. The value of $|A|$, if $A = \begin{bmatrix} 0 & 2x-1 & \sqrt{x} \\ 1-2x & 0 & 2\sqrt{x} \\ -\sqrt{x} & -2\sqrt{x} & 0 \end{bmatrix}$, where $x \in \mathbb{R}^+$, is

- (a) $(2x+1)^2$ (b) 0 (c) $(2x+1)^3$ (d) $(2x-1)^2$

Q11. The feasible region corresponding to the linear constraints of a Linear Programming Problem is given below.

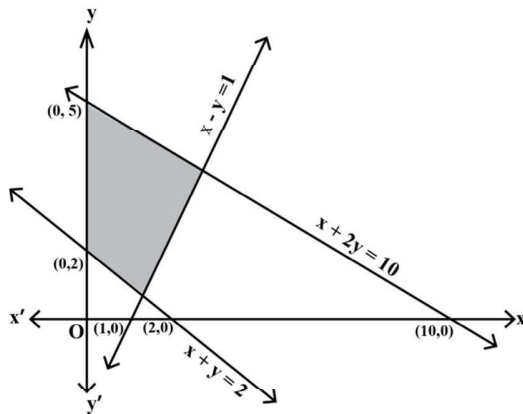

Which of the following is not a constraint to the given Linear Programming Problem?

- (a) $x + y \geq 2$ (b) $x + 2y \leq 10$ (c) $x - y \geq 1$ (d) $x - y \leq 1$

Q12. If $\vec{a} = 4\hat{i} + 6\hat{j}$ and $\vec{b} = 3\hat{j} + 4\hat{k}$, then the vector form of the component of \vec{a} along \vec{b} is
 (a) $\frac{18}{5}(3\hat{i} + 4\hat{k})$ (b) $\frac{18}{25}(3\hat{j} + 4\hat{k})$ (c) $\frac{18}{5}(3\hat{i} + 4\hat{k})$ (d) $\frac{18}{25}(4\hat{i} + 6\hat{j})$

Q13. Given that A is a square matrix of order 3 and $|A| = -2$, then $|\text{adj}(2A)|$ is equal to
 (a) -2^6 (b) $+4$ (c) -2^8 (d) 2^8

Q14. A problem in Mathematics is given to three students whose chances of solving it are $\frac{1}{2}, \frac{1}{3}, \frac{1}{4}$ respectively. If the events of their solving the problem are independent then the probability that the problem will be solved, is

(a) $\frac{1}{4}$ (b) $\frac{1}{3}$ (c) $\frac{1}{2}$ (d) $\frac{3}{4}$

Q15. The general solution of the differential equation $ydx - xdy = 0$; (Given $x, y > 0$), is of the form

(a) $xy = c$ (b) $x = cy^2$ (c) $y = cx$ (d) $y = cx^2$;

(Where 'c' is an arbitrary positive constant of integration)

Q16. The value of λ for which two vectors $2\hat{i} - \hat{j} + 2\hat{k}$ and $3\hat{i} + \lambda\hat{j} + \hat{k}$ are perpendicular is

(a) 2 (b) 4 (c) 6 (d) 8

Q17. The set of all points where the function $f(x) = x + |x|$ is differentiable, is

(a) $(0, \infty)$ (b) $(-\infty, 0)$ (c) $(-\infty, 0) \cup (0, \infty)$ (d) $(-\infty, \infty)$

Q18. If the direction cosines of a line are $\langle \frac{1}{c}, \frac{1}{c}, \frac{1}{c} \rangle$, then

(a) $0 < c < 1$ (b) $c > 2$ (c) $c = \pm\sqrt{2}$ (d) $c = \pm\sqrt{3}$

ASSERTION-REASON BASED QUESTIONS

In the following questions, a statement of Assertion (A) is followed by a statement of Reason (R).

Choose the correct answer out of the following choices.

- (a) Both (A) and (R) are true and (R) is the correct explanation of (A).
- (b) Both (A) and (R) are true but (R) is not the correct explanation of (A).
- (c) (A) is true but (R) is false.
- (d) (A) is false but (R) is true.

Q19. Let $f(x)$ be a polynomial function of degree 6 such that $\frac{d}{dx}(f(x)) = (x-1)^3(x-3)^2$, then

ASSERTION (A): $f(x)$ has a minimum at $x = 1$.

REASON (R): When $\frac{d}{dx}(f(x)) < 0, \forall x \in (a-h, a)$ and $\frac{d}{dx}(f(x)) > 0, \forall x \in (a, a+h)$; where 'h' is an infinitesimally small positive quantity, then $f(x)$ has a minimum at $x = a$, provided $f(x)$ is continuous at $x = a$.

Q20. ASSERTION (A): The relation $f : \{1,2,3,4\} \rightarrow \{x,y,z,p\}$ defined by $f = \{(1,x),(2,y),(3,z)\}$ is a bijective function.

REASON (R): The function $f : \{1,2,3\} \rightarrow \{x,y,z,p\}$ such that $f = \{(1,x),(2,y),(3,z)\}$ is one-one.

Section –B

[This section comprises of very short answer type questions (VSA) of 2 marks each]

Q21. Find the value of $\sin^{-1}\left(\cos\left(\frac{33\pi}{5}\right)\right)$.

OR

Find the domain of $\sin^{-1}(x^2 - 4)$.

Q22. Find the interval/s in which the function $f : \mathbb{R} \rightarrow \mathbb{R}$ defined by $f(x) = xe^x$, is increasing.

Q23. If $f(x) = \frac{1}{4x^2 + 2x + 1}$; $x \in \mathbb{R}$, then find the maximum value of $f(x)$.

OR

Find the maximum profit that a company can make, if the profit function is given by

$P(x) = 72 + 42x - x^2$, where x is the number of units and P is the profit in rupees.

Q24. Evaluate : $\int_{-1}^1 \log\left(\frac{2-x}{2+x}\right) dx$.

Q25. Check whether the function $f : \mathbb{R} \rightarrow \mathbb{R}$ defined by $f(x) = x^3 + x$, has any critical point/s or not ?
If yes, then find the point/s.

Section – C

[This section comprises of short answer type questions (SA) of 3 marks each]

Q26. Find : $\int \frac{2x^2 + 3}{x^2(x^2 + 9)} dx$; $x \neq 0$.

Q27. The random variable X has a probability distribution $P(X)$ of the following form, where ' k ' is some real number:

$$P(X) = \begin{cases} k, & \text{if } x=0 \\ 2k, & \text{if } x=1 \\ 3k, & \text{if } x=2 \\ 0, & \text{otherwise} \end{cases}$$

(i) Determine the value of k .

(ii) Find $P(X < 2)$.

(iii) Find $P(X > 2)$.

Q28. Find : $\int \sqrt{\frac{x}{1-x^3}} dx; \quad x \in (0,1)$.

OR

Evaluate: $\int_0^{\frac{\pi}{4}} \log(1 + \tan x) dx$.

Q29. Solve the differential equation: $ye^{\frac{x}{y}} dx = \left(xe^{\frac{x}{y}} + y^2\right) dy, \quad (y \neq 0)$.

OR

Solve the differential equation: $(\cos^2 x) \frac{dy}{dx} + y = \tan x; \quad \left(0 \leq x < \frac{\pi}{2}\right)$.

Q30. Solve the following Linear Programming Problem graphically:

Minimize: $z = x + 2y$,

subject to the constraints: $x + 2y \geq 100, 2x - y \leq 0, 2x + y \leq 200, x, y \geq 0$.

OR

Solve the following Linear Programming Problem graphically:

Maximize: $z = -x + 2y$,

subject to the constraints: $x \geq 3, x + y \geq 5, x + 2y \geq 6, y \geq 0$.

Q31. If $(a + bx)e^{\frac{y}{x}} = x$ then prove that $x \frac{d^2 y}{dx^2} = \left(\frac{a}{a + bx}\right)^2$.

Section -D

[This section comprises of long answer type questions (LA) of 5 marks each]

Q32. Make a rough sketch of the region $\{(x, y) : 0 \leq y \leq x^2 + 1, 0 \leq y \leq x + 1, 0 \leq x \leq 2\}$ and find the area of the region, using the method of integration.

Q33. Let \mathbb{N} be the set of all natural numbers and R be a relation on $\mathbb{N} \times \mathbb{N}$ defined by

$$(a, b)R(c, d) \Leftrightarrow ad = bc \text{ for all } (a, b), (c, d) \in \mathbb{N} \times \mathbb{N}. \text{ Show that } R \text{ is an equivalence relation on}$$

$\mathbb{N} \times \mathbb{N}$. Also, find the equivalence class of $(2, 6)$, i.e., $[(2, 6)]$.

OR

Show that the function $f : \mathbb{R} \rightarrow \{x \in \mathbb{R} : -1 < x < 1\}$ defined by $f(x) = \frac{x}{1 + |x|}$, $x \in \mathbb{R}$ is one-one and onto function.

Q34. Using the matrix method, solve the following system of linear equations :

$$\frac{2}{x} + \frac{3}{y} + \frac{10}{z} = 4, \quad \frac{4}{x} - \frac{6}{y} + \frac{5}{z} = 1, \quad \frac{6}{x} + \frac{9}{y} - \frac{20}{z} = 2.$$

Q35. Find the coordinates of the image of the point $(1, 6, 3)$ with respect to the line

$\vec{r} = (\hat{j} + 2\hat{k}) + \lambda(\hat{i} + 2\hat{j} + 3\hat{k})$; where ' λ ' is a scalar. Also, find the distance of the image from the y -axis.

OR

An aeroplane is flying along the line $\vec{r} = \lambda(\hat{i} - \hat{j} + \hat{k})$; where ' λ ' is a scalar and another aeroplane is flying along the line $\vec{r} = \hat{i} - \hat{j} + \mu(-2\hat{j} + \hat{k})$; where ' μ ' is a scalar. At what points on the lines should they reach, so that the distance between them is the shortest? Find the shortest possible distance between them.

Section –E

[This section comprises of 3 case- study/passage based questions of 4 marks each with sub parts. The first two case study questions have three sub parts (i), (ii), (iii) of marks 1,1,2 respectively. The third case study question has two sub parts of 2 marks each.]

Q36. Read the following passage and answer the questions given below:

In an Office three employees Jayant, Sonia and Oliver process incoming copies of a certain form. Jayant processes **50%** of the forms, Sonia processes **20%** and Oliver the remaining **30%** of the forms. Jayant has an error rate of **0.06**, Sonia has an error rate of **0.04** and Oliver has an error rate of **0.03**.

Based on the above information, answer the following questions.



- (i) Find the probability that Sonia processed the form and committed an error.
- (ii) Find the total probability of committing an error in processing the form.
- (iii) The manager of the Company wants to do a quality check. During inspection, he selects a form at random from the days output of processed form. If the form selected at random has an error, find the probability that the form is **not** processed by Jayant.

OR

- (iii) Let E be the event of committing an error in processing the form and let E_1, E_2 and E_3 be the events that Jayant, Sonia and Oliver processed the form. Find the value of $\sum_{i=1}^3 P(E_i | E)$.

Q37. Read the following passage and answer the questions given below:

Teams A, B, C went for playing a tug of war game. Teams A, B, C have attached a rope to a metal ring and is trying to pull the ring into their own area.

Team A pulls with force $F_1 = 6\hat{i} + 0\hat{j}$ kN,

Team B pulls with force $F_2 = -4\hat{i} + 4\hat{j}$ kN,

Team C pulls with force $F_3 = -3\hat{i} - 3\hat{j}$ kN,

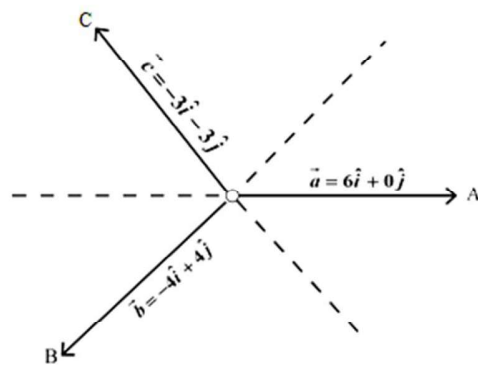

- What is the magnitude of the force of Team A ?
- Which team will win the game?
- Find the magnitude of the resultant force exerted by the teams.

OR

- In what direction is the ring getting pulled?

Q38. Read the following passage and answer the questions given below:

The relation between the height of the plant (' y ' in cm) with respect to its exposure to the sunlight

is governed by the following equation $y = 4x - \frac{1}{2}x^2$, where ' x ' is the number of days exposed to the

sunlight, for $x \leq 3$.



- Find the rate of growth of the plant with respect to the number of days exposed to the sunlight.

- (ii) Does the rate of growth of the plant increase or decrease in the first three days?
What will be the height of the plant after 2 days?

SAMPLE QUESTION PAPER

MARKING SCHEME

CLASS XII

MATHEMATICS (CODE-041)

SECTION: A (Solution of MCQs of 1 Mark each)

Q no.	ANS	HINTS/SOLUTION
1	(d)	$A = \begin{bmatrix} 0 & 1 \\ 1 & 0 \end{bmatrix}, A^2 = \begin{bmatrix} 1 & 0 \\ 0 & 1 \end{bmatrix}.$
2	(d)	$(A+B)^{-1} = B^{-1} + A^{-1}.$
3	(b)	$\text{Area} = \frac{1}{2} \begin{vmatrix} -3 & 0 & 1 \\ 3 & 0 & 1 \\ 0 & k & 1 \end{vmatrix}, \text{ given that the area} = 9 \text{ sq unit.}$ $\Rightarrow \pm 9 = \frac{1}{2} \begin{vmatrix} -3 & 0 & 1 \\ 3 & 0 & 1 \\ 0 & k & 1 \end{vmatrix}; \text{ expanding along } C_2, \text{ we get } \Rightarrow k = \pm 3.$
4	(a)	<p>Since, f is continuous at $x = 0$,</p> <p>therefore, $L.H.L = R.H.L = f(0) = a$ finite quantity.</p> $\lim_{x \rightarrow 0^-} f(x) = \lim_{x \rightarrow 0^+} f(x) = f(0)$ $\Rightarrow \lim_{x \rightarrow 0^-} \frac{-kx}{x} = \lim_{x \rightarrow 0^+} 3 = 3 \Rightarrow k = -3.$
5	(d)	<p>Vectors $2\hat{i} + 3\hat{j} - 6\hat{k}$ & $6\hat{i} + 9\hat{j} - 18\hat{k}$ are parallel and the fixed point $\hat{i} + \hat{j} - \hat{k}$ on the line $\vec{r} = \hat{i} + \hat{j} - \hat{k} + \lambda(2\hat{i} + 3\hat{j} - 6\hat{k})$ does not satisfy the other line $\vec{r} = 2\hat{i} - \hat{j} - \hat{k} + \mu(6\hat{i} + 9\hat{j} - 18\hat{k})$; where λ & μ are scalars.</p>
6	(c)	The degree of the differential equation $\left[1 + \left(\frac{dy}{dx}\right)^2\right]^3 = \left(\frac{d^2y}{dx^2}\right)^2$ is 2
7	(b)	<p>$Z = px + qy$ --- (i)</p> <p>At $(3,0)$, $Z = 3p$ --- (ii) and at $(1,1)$, $Z = p + q$ --- (iii)</p> <p>From (ii) & (iii), $3p = p + q \Rightarrow 2p = q.$</p>

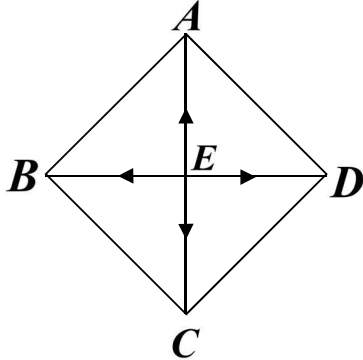
8	(a)	<p>Given, $ABCD$ is a rhombus whose diagonals bisect each other. $\vec{EA} = \vec{EC}$ and $\vec{EB} = \vec{ED}$ but since they are opposite to each other so they are of opposite signs $\Rightarrow \vec{EA} = -\vec{EC}$ and $\vec{EB} = -\vec{ED}$.</p>  <p>$\Rightarrow \vec{EA} + \vec{EC} = \vec{O} \dots (i)$ and $\vec{EB} + \vec{ED} = \vec{O} \dots (ii)$ Adding (i) and (ii), we get $\vec{EA} + \vec{EB} + \vec{EC} + \vec{ED} = \vec{O}$.</p>
9	(b)	$f(x) = e^{\cos^2 x} \sin^3(2n+1)x$ $f(-x) = e^{\cos^2(-x)} \sin^3(2n+1)(-x)$ $f(-x) = -e^{\cos^2 x} \sin^3(2n+1)x$ $\therefore f(-x) = -f(x)$ <p>So, $\int_{-\pi}^{\pi} e^{\cos^2 x} \sin^3(2n+1)x dx = 0$</p>
10	(b)	Matrix A is a skew symmetric matrix of odd order. $\therefore A = 0$.
11	(c)	<p>We observe, $(0,0)$ does not satisfy the inequality $x - y \geq 1$</p> <p>So, the half plane represented by the above inequality will not contain origin therefore, it will not contain the shaded feasible region.</p>
12	(b)	Vector component of \vec{a} along $\vec{b} = \left(\frac{\vec{a} \cdot \vec{b}}{ \vec{b} ^2} \right) \vec{b} = \frac{18}{25} (3\hat{j} + 4\hat{k})$.
13	(d)	$ adj(2A) = (2A) ^2 = (2^3 A)^2 = 2^6 A ^2 = 2^6 \times (-2)^2 = 2^8$.
14	(d)	<p>Method 1:</p> <p>Let A, B, C be the respective events of solving the problem. Then, $P(A) = \frac{1}{2}, P(B) = \frac{1}{3}$ and $P(C) = \frac{1}{4}$. Here, A, B, C are independent events.</p> <p>Problem is solved if at least one of them solves the problem.</p> <p>Required probability is $= P(A \cup B \cup C) = 1 - P(\bar{A})P(\bar{B})P(\bar{C})$</p>

$$= 1 - \left(1 - \frac{1}{2}\right) \left(1 - \frac{1}{3}\right) \left(1 - \frac{1}{4}\right) = 1 - \frac{1}{4} = \frac{3}{4}.$$

Method 2:

The problem will be solved if one or more of them can solve the problem. The probability is

$$P(\overline{A}\overline{B}\overline{C}) + P(\overline{A}\overline{B}C) + P(\overline{A}B\overline{C}) + P(\overline{A}BC) + P(A\overline{B}\overline{C}) + P(A\overline{B}C) + P(AB\overline{C}) + P(ABC)$$

$$= \frac{1}{2} \cdot \frac{2}{3} \cdot \frac{3}{4} + \frac{1}{2} \cdot \frac{2}{3} \cdot \frac{1}{4} + \frac{1}{2} \cdot \frac{1}{3} \cdot \frac{3}{4} + \frac{1}{2} \cdot \frac{1}{3} \cdot \frac{1}{4} + \frac{1}{2} \cdot \frac{2}{3} \cdot \frac{1}{4} + \frac{1}{2} \cdot \frac{1}{3} \cdot \frac{1}{4} + \frac{1}{2} \cdot \frac{1}{3} \cdot \frac{3}{4} + \frac{1}{2} \cdot \frac{1}{3} \cdot \frac{1}{4} = \frac{3}{4}.$$

Method 3:

Let us think quantitatively. Let us assume that there are 100 questions given to A . A

solves $\frac{1}{2} \times 100 = 50$ questions then remaining 50 questions is given to B and B solves

$50 \times \frac{1}{3} = 16.67$ questions. Remaining $50 \times \frac{2}{3}$ questions is given to C and C solves

$$50 \times \frac{2}{3} \times \frac{1}{4} = 8.33 \text{ questions.}$$

Therefore, number of questions solved is $50 + 16.67 + 8.33 = 75$.

So, required probability is $\frac{75}{100} = \frac{3}{4}$.

15

(c)

Method 1:

$$ydx - xdy = 0 \Rightarrow \frac{ydx - xdy}{y^2} = 0 \Rightarrow d\left(\frac{x}{y}\right) = 0 \Rightarrow x = \frac{1}{c}y \Rightarrow y = cx.$$

Method 2:

$$ydx - xdy = 0 \Rightarrow ydx = xdy \Rightarrow \frac{dy}{y} = \frac{dx}{x}; \text{ on integrating } \int \frac{dy}{y} = \int \frac{dx}{x}$$

$$\log_e |y| = \log_e |x| + \log_e |c|$$

since $x, y, c > 0$, we write $\log_e y = \log_e x + \log_e c \Rightarrow y = cx$.

16

(d)

Dot product of two mutually perpendicular vectors is zero.

$$\Rightarrow 2 \times 3 + (-1)\lambda + 2 \times 1 = 0 \Rightarrow \lambda = 8.$$

17

(c)

Method 1:

$$f(x) = x + |x| = \begin{cases} 2x, & x \geq 0 \\ 0, & x < 0 \end{cases}$$

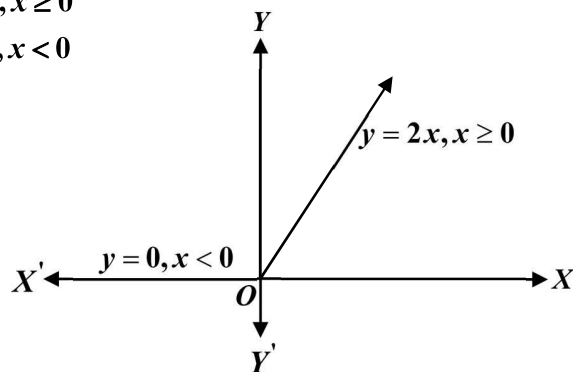

There is a sharp corner at $x = 0$, so $f(x)$ is not differentiable at $x = 0$.

Method 2:

		$Lf'(0) = 0$ & $Rf'(0) = 2$; so, the function is not differentiable at $x = 0$ For $x \geq 0, f(x) = 2x$ (linear function) & when $x < 0, f(x) = 0$ (constant function) Hence $f(x)$ is differentiable when $x \in (-\infty, 0) \cup (0, \infty)$.
18	(d)	We know, $l^2 + m^2 + n^2 = 1 \Rightarrow \left(\frac{1}{c}\right)^2 + \left(\frac{1}{c}\right)^2 + \left(\frac{1}{c}\right)^2 = 1 \Rightarrow 3\left(\frac{1}{c}\right)^2 = 1 \Rightarrow c = \pm\sqrt{3}$.
19	(a)	$\frac{d}{dx}(f(x)) = (x-1)^3(x-3)^2$ Assertion : $f(x)$ has a minimum at $x = 1$ is true as $\frac{d}{dx}(f(x)) < 0, \forall x \in (1-h, 1)$ and $\frac{d}{dx}(f(x)) > 0, \forall x \in (1, 1+h)$; where, 'h' is an infinitesimally small positive quantity, which is in accordance with the Reason statement.
20	(d)	Assertion is false. As element 4 has no image under f , so relation f is not a function. Reason is true. The given function $f: \{1, 2, 3\} \rightarrow \{x, y, z, p\}$ is one – one, as for each $a \in \{1, 2, 3\}$, there is different image in $\{x, y, z, p\}$ under f .

Section –B

[This section comprises of solution of very short answer type questions (VSA) of 2 marks each]

21	$\sin^{-1}\left(\cos\left(\frac{33\pi}{5}\right)\right) = \sin^{-1}\cos\left(6\pi + \frac{3\pi}{5}\right) = \sin^{-1}\cos\left(\frac{3\pi}{5}\right) = \sin^{-1}\sin\left(\frac{\pi}{2} - \frac{3\pi}{5}\right)$ $= \frac{\pi}{2} - \frac{3\pi}{5} = -\frac{\pi}{10}$.	1 1
21 OR	$-1 \leq (x^2 - 4) \leq 1 \Rightarrow 3 \leq x^2 \leq 5 \Rightarrow \sqrt{3} \leq x \leq \sqrt{5}$ $\Rightarrow x \in [-\sqrt{5}, -\sqrt{3}] \cup [\sqrt{3}, \sqrt{5}]$. So, required domain is $[-\sqrt{5}, -\sqrt{3}] \cup [\sqrt{3}, \sqrt{5}]$.	1 1
22	$f(x) = xe^x \Rightarrow f'(x) = e^x(x+1)$ When $x \in [-1, \infty), (x+1) \geq 0$ & $e^x > 0 \Rightarrow f'(x) \geq 0 \therefore f(x)$ increases in this interval. or, we can write $f(x) = xe^x \Rightarrow f'(x) = e^x(x+1)$ For $f(x)$ to be increasing, we have $f'(x) = e^x(x+1) \geq 0 \Rightarrow x \geq -1$ as $e^x > 0, \forall x \in \mathbb{R}$ Hence, the required interval where $f(x)$ increases is $[-1, \infty)$.	1 1 $\frac{1}{2}$ 1 $\frac{1}{2}$
23	Method 1 : $f(x) = \frac{1}{4x^2 + 2x + 1}$,	

Let $g(x) = 4x^2 + 2x + 1 = 4\left(x^2 + 2x\frac{1}{4} + \frac{1}{16}\right) + \frac{3}{4} = 4\left(x + \frac{1}{4}\right)^2 + \frac{3}{4} \geq \frac{3}{4}$	$\frac{1}{2}$
\therefore maximum value of $f(x) = \frac{4}{3}$.	$\frac{1}{2}$
Method 2 : $f(x) = \frac{1}{4x^2 + 2x + 1}$, let $g(x) = 4x^2 + 2x + 1$	
$\Rightarrow \frac{d}{dx}(g(x)) = g'(x) = 8x + 2$ and $g'(x) = 0$ at $x = -\frac{1}{4}$ also $\frac{d^2}{dx^2}(g(x)) = g''(x) = 8 > 0$	1
$\Rightarrow g(x)$ is minimum when $x = -\frac{1}{4}$ so, $f(x)$ is maximum at $x = -\frac{1}{4}$	$\frac{1}{2}$
\therefore maximum value of $f(x) = f\left(-\frac{1}{4}\right) = \frac{1}{4\left(-\frac{1}{4}\right)^2 + 2\left(-\frac{1}{4}\right) + 1} = \frac{4}{3}$.	$\frac{1}{2}$
Method 3 : $f(x) = \frac{1}{4x^2 + 2x + 1}$	
On differentiating w.r.t x , we get $f'(x) = \frac{-(8x + 2)}{(4x^2 + 2x + 1)^2}$(i)	$\frac{1}{2}$
For maxima or minima, we put $f'(x) = 0 \Rightarrow 8x + 2 = 0 \Rightarrow x = -\frac{1}{4}$.	$\frac{1}{2}$
Again, differentiating equation (i) w.r.t. x , we get	
$f''(x) = -\left\{\frac{(4x^2 + 2x + 1)^2(8) - (8x + 2)2 \times (4x^2 + 2x + 1)(8x + 2)}{(4x^2 + 2x + 1)^4}\right\}$	$\frac{1}{2}$
At $x = -\frac{1}{4}$, $f''\left(-\frac{1}{4}\right) < 0$	
$f(x)$ is maximum at $x = -\frac{1}{4}$.	
\therefore maximum value of $f(x)$ is $f\left(-\frac{1}{4}\right) = \frac{1}{4\left(-\frac{1}{4}\right)^2 + 2\left(-\frac{1}{4}\right) + 1} = \frac{4}{3}$.	$\frac{1}{2}$
Method 4: $f(x) = \frac{1}{4x^2 + 2x + 1}$	
On differentiating w.r.t x , we get $f'(x) = \frac{-(8x + 2)}{(4x^2 + 2x + 1)^2}$(i)	$\frac{1}{2}$
For maxima or minima, we put $f'(x) = 0 \Rightarrow 8x + 2 = 0 \Rightarrow x = -\frac{1}{4}$.	$\frac{1}{2}$
When $x \in \left(-h - \frac{1}{4}, -\frac{1}{4}\right)$, where ' h ' is infinitesimally small positive quantity.	
$4x < -1 \Rightarrow 8x < -2 \Rightarrow 8x + 2 < 0 \Rightarrow -(8x + 2) > 0$ and $(4x^2 + 2x + 1)^2 > 0 \Rightarrow f'(x) > 0$	

	<p>and when $x \in \left(-\frac{1}{4}, -\frac{1}{4} + h\right)$, $4x > -1 \Rightarrow 8x > -2 \Rightarrow 8x + 2 > 0 \Rightarrow -(8x + 2) < 0$</p> <p>and $(4x^2 + 2x + 1)^2 > 0 \Rightarrow f'(x) < 0$. This shows that $x = -\frac{1}{4}$ is the point of local maxima.</p> <p>\therefore maximum value of $f(x)$ is $f\left(-\frac{1}{4}\right) = \frac{1}{4\left(-\frac{1}{4}\right)^2 + 2\left(-\frac{1}{4}\right) + 1} = \frac{4}{3}$.</p>	$\frac{1}{2}$ $\frac{1}{2}$
23 OR	<p>For maxima and minima, $P'(x) = 0 \Rightarrow 42 - 2x = 0$</p> <p>$\Rightarrow x = 21$ and $P''(x) = -2 < 0$</p> <p>So, $P(x)$ is maximum at $x = 21$.</p> <p>The maximum value of $P(x) = 72 + (42 \times 21) - (21)^2 = 513$ i.e., the maximum profit is ₹ 513.</p>	$\frac{1}{2}$ $\frac{1}{2}$ 1
24	<p>Let $f(x) = \log\left(\frac{2-x}{2+x}\right)$</p> <p>We have, $f(-x) = \log\left(\frac{2+x}{2-x}\right) = -\log\left(\frac{2-x}{2+x}\right) = -f(x)$</p> <p>So, $f(x)$ is an odd function. $\therefore \int_{-1}^1 \log\left(\frac{2-x}{2+x}\right) dx = 0$.</p>	 1 1
25	<p>$f(x) = x^3 + x$, for all $x \in \mathbb{R}$.</p> <p>$\frac{d}{dx}(f(x)) = f'(x) = 3x^2 + 1$; for all $x \in \mathbb{R}$, $x^2 \geq 0 \Rightarrow f'(x) > 0$</p> <p>Hence, no critical point exists.</p>	$\frac{1}{2}$ $\frac{1}{2}$
Section – C		
[This section comprises of solution short answer type questions (SA) of 3 marks each]		
26	<p>We have, $\frac{2x^2 + 3}{x^2(x^2 + 9)}$. Now, let $x^2 = t$</p> <p>So, $\frac{2t + 3}{t(t + 9)} = \frac{A}{t} + \frac{B}{t + 9}$, we get $A = \frac{1}{3}$ & $B = \frac{5}{3}$</p> <p>$\int \frac{2x^2 + 3}{x^2(x^2 + 9)} dx = \frac{1}{3} \int \frac{dx}{x^2} + \frac{5}{3} \int \frac{dx}{x^2 + 9}$</p> <p>$= -\frac{1}{3x} + \frac{5}{9} \tan^{-1}\left(\frac{x}{3}\right) + c$, where 'c' is an arbitrary constant of integration.</p>	$\frac{1}{2}$ 1 $\frac{1}{2}$ 1
27	<p>We have, (i) $\sum P(X_i) = 1 \Rightarrow k + 2k + 3k = 1 \Rightarrow k = \frac{1}{6}$.</p>	 1 1

	<p>(ii) $P(X < 2) = P(X = 0) + P(X = 1) = k + 2k = 3k = 3 \times \frac{1}{6} = \frac{1}{2}$.</p> <p>(iii) $P(X > 2) = 0$.</p>	1
28	<p>Let $x^{\frac{3}{2}} = t \Rightarrow dt = \frac{3}{2} x^{\frac{1}{2}} dx$</p> $\int \sqrt{\frac{x}{1-x^3}} dx = \frac{2}{3} \int \frac{dt}{\sqrt{1-t^2}}$ $= \frac{2}{3} \sin^{-1}(t) + c$ $= \frac{2}{3} \sin^{-1}\left(x^{\frac{3}{2}}\right) + c, \text{ where 'c' is an arbitrary constant of integration.}$	<p>$\frac{1}{2}$</p> <p>$\frac{1}{2}$</p> <p>1</p> <p>1</p>
28 OR	<p>Let $I = \int_0^{\frac{\pi}{4}} \log_e(1 + \tan x) dx$ -----(i)</p> $= \int_0^{\frac{\pi}{4}} \log_e\left(1 + \tan\left(\frac{\pi}{4} - x\right)\right) dx, \text{ Using, } \int_0^a f(x) dx = \int_0^a f(a-x) dx$ $\Rightarrow I = \int_0^{\frac{\pi}{4}} \log_e\left(1 + \frac{1 - \tan x}{1 + \tan x}\right) dx = \int_0^{\frac{\pi}{4}} \log_e\left(\frac{2}{1 + \tan x}\right) dx = \int_0^{\frac{\pi}{4}} \log_e 2 dx - I \text{ (Using -----(i))}$ $I = \frac{\pi}{4} \log_e 2 \Rightarrow I = \frac{\pi}{8} \log_e 2.$	<p>1</p> <p>1</p> <p>1</p> <p>1</p>
29	<p>Method 1: $ye^{\frac{x}{y}} dx = \left(xe^{\frac{x}{y}} + y^2\right) dy \Rightarrow e^{\frac{x}{y}}(ydx - xdy) = y^2 dy \Rightarrow e^{\frac{x}{y}} \left(\frac{ydx - xdy}{y^2}\right) = dy$</p> $\Rightarrow e^{\frac{x}{y}} d\left(\frac{x}{y}\right) = dy$ $\Rightarrow \int e^{\frac{x}{y}} d\left(\frac{x}{y}\right) = \int dy \Rightarrow e^{\frac{x}{y}} = y + c, \text{ where 'c' is an arbitrary constant of integration.}$ <p>Method 2: We have, $\frac{dx}{dy} = \frac{xe^{\frac{x}{y}} + y^2}{y \cdot e^{\frac{x}{y}}}$</p> $\Rightarrow \frac{dx}{dy} = \frac{x}{y} + \frac{y}{e^{\frac{x}{y}}} \dots\dots\dots (i)$ <p>Let $x = vy \Rightarrow \frac{dx}{dy} = v + y \cdot \frac{dv}{dy}$;</p>	<p>1</p> <p>1</p> <p>1</p> <p>$\frac{1}{2}$</p> <p>$\frac{1}{2}$</p>

	<p>So equation (i) becomes $v + y \frac{dv}{dy} = v + \frac{y}{e^v}$</p> $\Rightarrow y \frac{dv}{dy} = \frac{y}{e^v}$ $\Rightarrow e^v dv = dy$ <p>On integrating we get, $\int e^v dv = \int dy \Rightarrow e^v = y + c \Rightarrow e^{x/y} = y + c$</p> <p>where 'c' is an arbitrary constant of integration.</p>	$\frac{1}{2}$ $\frac{1}{2}$ $\frac{1}{2}$ $\frac{1}{2}$
<p>29 OR</p>	<p>The given Differential equation is</p> $(\cos^2 x) \frac{dy}{dx} + y = \tan x$ <p>Dividing both the sides by $\cos^2 x$, we get</p> $\frac{dy}{dx} + \frac{y}{\cos^2 x} = \frac{\tan x}{\cos^2 x}$ $\frac{dy}{dx} + y(\sec^2 x) = \tan x(\sec^2 x) \dots\dots (i)$ <p>Comparing with $\frac{dy}{dx} + Py = Q$</p> $P = \sec^2 x, Q = \tan x \cdot \sec^2 x$ <p>The Integrating factor is, $IF = e^{\int P dx} = e^{\int \sec^2 x dx} = e^{\tan x}$</p> <p>On multiplying the equation (i) by $e^{\tan x}$, we get</p> $\frac{d}{dx}(y \cdot e^{\tan x}) = e^{\tan x} \tan x(\sec^2 x) \Rightarrow d(y \cdot e^{\tan x}) = e^{\tan x} \tan x(\sec^2 x) dx$ <p>On integrating we get, $y \cdot e^{\tan x} = \int t \cdot e^t dt + c_1$; where, $t = \tan x$ so that $dt = \sec^2 x dx$</p> $= te^t - e^t + c = (\tan x)e^{\tan x} - e^{\tan x} + c$ <p>$\therefore y = \tan x - 1 + c \cdot (e^{-\tan x})$, where 'c₁' & 'c' are arbitrary constants of integration.</p>	$\frac{1}{2}$ $\frac{1}{2}$ 1 1
<p>30</p>	<p>The feasible region determined by the constraints, $x + 2y \geq 100$, $2x - y \leq 0$, $2x + y \leq 200$, $x, y \geq 0$, is given below.</p>	

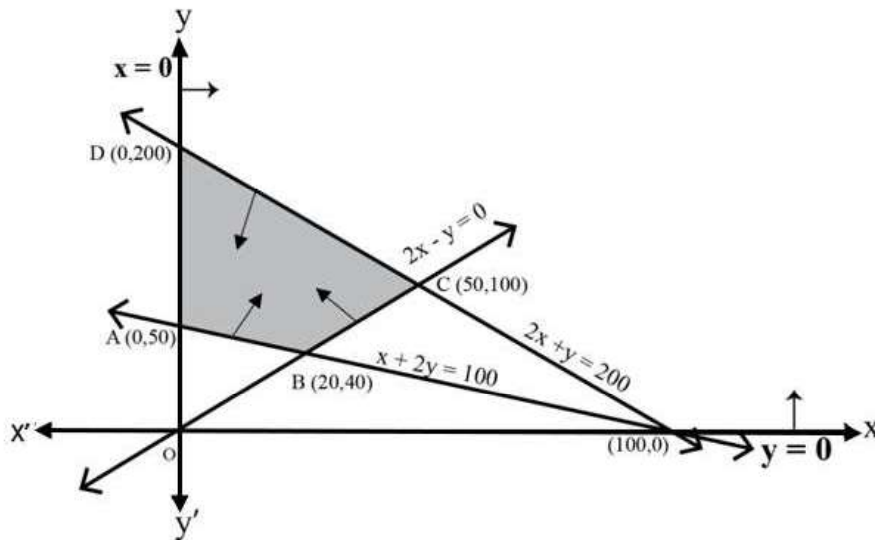

$A (0, 50)$, $B (20, 40)$, $C (50, 100)$ and $D (0, 200)$ are the corner points of the feasible region.

The values of Z at these corner points are given below.

Corner point	Corresponding value of $Z = x + 2y$	
$A (0, 50)$	100	Minimum
$B (20, 40)$	100	Minimum
$C (50, 100)$	250	
$D (0, 200)$	400	

The minimum value of Z is **100** at all the points on the line segment joining the points **(0,50)** and **(20,40)**.

The feasible region determined by the constraints, $x \geq 3$, $x + y \geq 5$, $x + 2y \geq 6$, $y \geq 0$ is given below.

$1\frac{1}{2}$

1

$\frac{1}{2}$

$1\frac{1}{2}$

Here, it
be seen
the

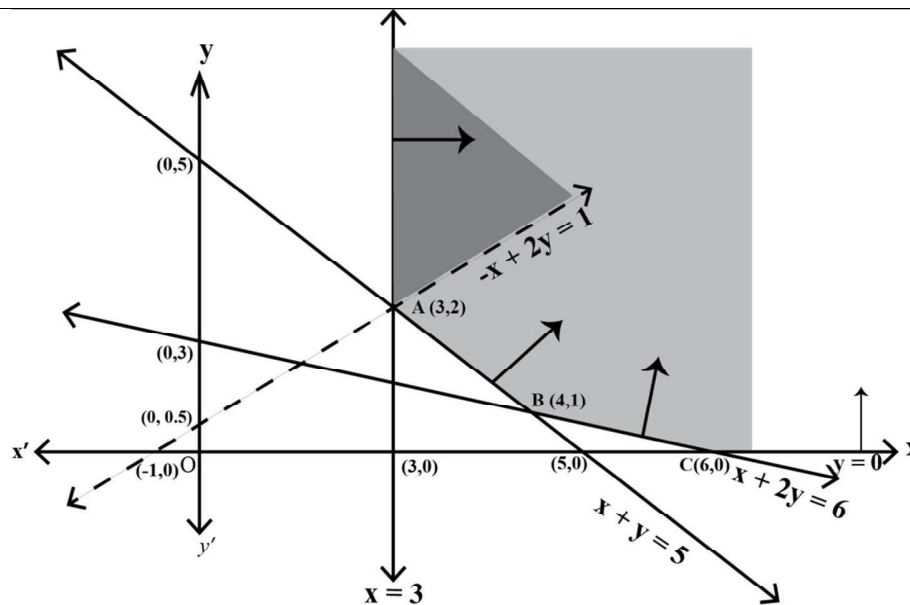

can
that

1

feasible region is unbounded.

The values of Z at corner points $A(3, 2)$, $B(4, 1)$ and $C(6, 0)$ are given below.

Corner point	Corresponding value of $Z = -x + 2y$
$A(3, 2)$	1 (may or may not be the maximum value)
$B(4, 1)$	-2
$C(6, 0)$	-6

$\frac{1}{2}$

Since the feasible region is unbounded, $Z = 1$ may or may not be the maximum value.

Now, we draw the graph of the inequality, $-x + 2y > 1$, and we check whether the resulting open half-plane has any point/s, in common with the feasible region or not.

Here, the resulting open half plane has points in common with the feasible region.

Hence, $Z = 1$ is not the maximum value. We conclude, Z has no maximum value.

31

$$\frac{y}{x} = \log_e \left(\frac{x}{a+bx} \right) = \log_e x - \log_e (a+bx)$$

On differentiating with respect to x , we get

$$\Rightarrow \frac{x \frac{dy}{dx} - y}{x^2} = \frac{1}{x} - \frac{1}{a+bx} \frac{d}{dx}(a+bx) = \frac{1}{x} - \frac{b}{a+bx}$$

$$\Rightarrow x \frac{dy}{dx} - y = x^2 \left(\frac{1}{x} - \frac{b}{a+bx} \right) = \frac{ax}{a+bx}$$

On differentiating again with respect to x , we get

$$\Rightarrow x \frac{d^2 y}{dx^2} + \frac{dy}{dx} - \frac{dy}{dx} = \frac{(a+bx)a - ax(b)}{(a+bx)^2}$$

$\frac{1}{2}$

1

$\frac{1}{2}$

$\frac{1}{2}$

$$\Rightarrow x \frac{d^2 y}{dx^2} = \left(\frac{a}{a+bx} \right)^2.$$

$\frac{1}{2}$

Section –D

[This section comprises of solution of long answer type questions (LA) of 5 marks each]

32

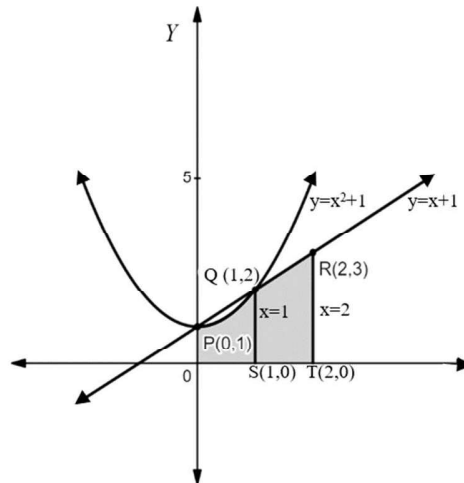

1

To find the point of intersections of the curve $y = x^2 + 1$ and the line $y = x + 1$, we write $x^2 + 1 = x + 1 \Rightarrow x(x - 1) = 0 \Rightarrow x = 0, 1$.

So, the point of intersections $P(0, 1)$ and $Q(1, 2)$.

1

Area of the shaded region $OPQRTSO = (\text{Area of the region } OSQPO + \text{Area of the region } STRQS)$

$$= \int_0^1 (x^2 + 1) dx + \int_1^2 (x + 1) dx$$

$$= \left[\frac{x^3}{3} + x \right]_0^1 + \left[\frac{x^2}{2} + x \right]_1^2$$

$$= \left[\left(\frac{1}{3} + 1 \right) - 0 \right] + \left[(2 + 2) - \left(\frac{1}{2} + 1 \right) \right]$$

$$= \frac{23}{6}$$

Hence the required area is $\frac{23}{6}$ sq units.

1

$\frac{1}{2}$

$\frac{1}{2}$

1

33

Let (a, b) be an arbitrary element of $\mathbb{N} \times \mathbb{N}$. Then, $(a, b) \in \mathbb{N} \times \mathbb{N}$ and $a, b \in \mathbb{N}$

We have, $ab = ba$; (As $a, b \in \mathbb{N}$ and multiplication is commutative on \mathbb{N})

$\Rightarrow (a, b) R (a, b)$, according to the definition of the relation R on $\mathbb{N} \times \mathbb{N}$

Thus $(a, b) R (a, b), \forall (a, b) \in \mathbb{N} \times \mathbb{N}$.

So, R is reflexive relation on $\mathbb{N} \times \mathbb{N}$.

Let $(a, b), (c, d)$ be arbitrary elements of $\mathbb{N} \times \mathbb{N}$ such that $(a, b) R (c, d)$.

1

	<p>Then, $(a, b)R(c, d) \Rightarrow ad = bc \Rightarrow bc = ad$; (changing LHS and RHS) $\Rightarrow cb = da$; (As $a, b, c, d \in \mathbb{N}$ and multiplication is commutative on \mathbb{N}) $\Rightarrow (c, d)R(a, b)$; according to the definition of the relation R on $\mathbb{N} \times \mathbb{N}$ Thus $(a, b)R(c, d) \Rightarrow (c, d)R(a, b)$ So, R is symmetric relation on $\mathbb{N} \times \mathbb{N}$.</p> <p>Let $(a, b), (c, d), (e, f)$ be arbitrary elements of $\mathbb{N} \times \mathbb{N}$ such that $(a, b)R(c, d)$ and $(c, d)R(e, f)$.</p> <p>Then $\left. \begin{array}{l} (a, b)R(c, d) \Rightarrow ad = bc \\ (c, d)R(e, f) \Rightarrow cf = de \end{array} \right\} \Rightarrow (ad)(cf) = (bc)(de) \Rightarrow af = be$ $\Rightarrow (a, b)R(e, f)$; (according to the definition of the relation R on $\mathbb{N} \times \mathbb{N}$) Thus $(a, b)R(c, d)$ and $(c, d)R(e, f) \Rightarrow (a, b)R(e, f)$ So, R is transitive relation on $\mathbb{N} \times \mathbb{N}$.</p> <p>As the relation R is reflexive, symmetric and transitive so, it is equivalence relation on $\mathbb{N} \times \mathbb{N}$. $[(2, 6)] = \{(x, y) \in \mathbb{N} \times \mathbb{N} : (x, y)R(2, 6)\}$ $= \{(x, y) \in \mathbb{N} \times \mathbb{N} : 3x = y\}$ $= \{(x, 3x) : x \in \mathbb{N}\} = \{(1, 3), (2, 6), (3, 9), \dots\}$</p>	<p>1</p> <p>$\frac{1}{2}$</p> <p>$\frac{1}{2}$</p> <p>1</p>
<p>33 OR</p>	<p>We have, $f(x) = \begin{cases} \frac{x}{1+x}, & \text{if } x \geq 0 \\ \frac{x}{1-x}, & \text{if } x < 0 \end{cases}$</p> <p>Now, we consider the following cases</p> <p>Case 1: when $x \geq 0$, we have $f(x) = \frac{x}{1+x}$</p> <p>Injectivity: let $x, y \in \mathbb{R}^+ \cup \{0\}$ such that $f(x) = f(y)$, then $\Rightarrow \frac{x}{1+x} = \frac{y}{1+y} \Rightarrow x + xy = y + xy \Rightarrow x = y$</p> <p>So, f is injective function.</p> <p>Surjectivity: when $x \geq 0$, we have $f(x) = \frac{x}{1+x} \geq 0$ and $f(x) = 1 - \frac{1}{1+x} < 1$, as $x \geq 0$</p> <p>Let $y \in [0, 1)$, thus for each $y \in [0, 1)$ there exists $x = \frac{y}{1-y} \geq 0$ such that $f(x) = \frac{\frac{y}{1-y}}{1 + \frac{y}{1-y}} = y$.</p>	<p>1</p> <p>1</p>

So, f is onto function on $[0, \infty)$ to $[0, 1)$.

Case 2: when $x < 0$, we have $f(x) = \frac{x}{1-x}$

Injectivity: Let $x, y \in \mathbb{R}^-$ i.e., $x, y < 0$, such that $f(x) = f(y)$, then

$$\Rightarrow \frac{x}{1-x} = \frac{y}{1-y} \Rightarrow x - xy = y - xy \Rightarrow x = y$$

So, f is injective function.

Surjectivity : $x < 0$, we have $f(x) = \frac{x}{1-x} < 0$ also, $f(x) = \frac{x}{1-x} = -1 + \frac{1}{1-x} > -1$
 $-1 < f(x) < 0$.

Let $y \in (-1, 0)$ be an arbitrary real number and there exists $x = \frac{y}{1+y} < 0$ such that,

$$f(x) = f\left(\frac{y}{1+y}\right) = \frac{\frac{y}{1+y}}{1 - \frac{y}{1+y}} = y.$$

So, for $y \in (-1, 0)$, there exists $x = \frac{y}{1+y} < 0$ such that $f(x) = y$.

Hence, f is onto function on $(-\infty, 0)$ to $(-1, 0)$.

Case 3:

(Injectivity): Let $x > 0$ & $y < 0$ such that $f(x) = f(y) \Rightarrow \frac{x}{1+x} = \frac{y}{1-y}$

$\Rightarrow x - xy = y + xy \Rightarrow x - y = 2xy$, here $LHS > 0$ but $RHS < 0$, which is inadmissible.

Hence, $f(x) \neq f(y)$ when $x \neq y$.

Hence f is one-one and onto function.

1

1

1

34

The given system of equations can be written in the form $AX = B$,

$$\text{Where, } A = \begin{bmatrix} 2 & 3 & 10 \\ 4 & -6 & 5 \\ 6 & 9 & -20 \end{bmatrix}, X = \begin{bmatrix} 1/x \\ 1/y \\ 1/z \end{bmatrix} \text{ and } B = \begin{bmatrix} 4 \\ 1 \\ 2 \end{bmatrix}$$

$$\text{Now, } |A| = \begin{vmatrix} 2 & 3 & 10 \\ 4 & -6 & 5 \\ 6 & 9 & -20 \end{vmatrix} = 2(120 - 45) - 3(-80 - 30) + 10(36 + 36)$$

$$= 2(75) - 3(-110) + 10(72) = 150 + 330 + 720 = 1200 \neq 0 \therefore A^{-1} \text{ exists.}$$

$$\therefore \text{adj } A = \begin{bmatrix} 75 & 110 & 72 \\ 150 & -100 & 0 \\ 75 & 30 & -24 \end{bmatrix}^T = \begin{bmatrix} 75 & 150 & 75 \\ 110 & -100 & 30 \\ 72 & 0 & -24 \end{bmatrix}$$

$\frac{1}{2}$

$\frac{1}{2}$

$\frac{1}{2}$

$$\text{Hence, } A^{-1} = \frac{1}{|A|}(\text{adj}A) = \frac{1}{1200} \begin{bmatrix} 75 & 150 & 75 \\ 110 & -100 & 30 \\ 72 & 0 & -24 \end{bmatrix}$$

$$\text{As, } AX = B \Rightarrow X = A^{-1}B \Rightarrow \begin{bmatrix} \frac{1}{x} \\ \frac{1}{y} \\ \frac{1}{z} \end{bmatrix} = \frac{1}{1200} \begin{bmatrix} 75 & 150 & 75 \\ 110 & -100 & 30 \\ 72 & 0 & -24 \end{bmatrix} \begin{bmatrix} 4 \\ 1 \\ 2 \end{bmatrix}$$

$$= \frac{1}{1200} \begin{bmatrix} 300 + 150 + 150 \\ 440 - 100 + 60 \\ 288 + 0 - 48 \end{bmatrix} \Rightarrow \begin{bmatrix} \frac{1}{x} \\ \frac{1}{y} \\ \frac{1}{z} \end{bmatrix} = \frac{1}{1200} \begin{bmatrix} 600 \\ 400 \\ 240 \end{bmatrix} = \begin{bmatrix} \frac{1}{2} \\ \frac{1}{3} \\ \frac{1}{5} \end{bmatrix}$$

$$\text{Thus, } \frac{1}{x} = \frac{1}{2}, \frac{1}{y} = \frac{1}{3}, \frac{1}{z} = \frac{1}{5} \quad \text{Hence, } x = 2, y = 3, z = 5.$$

$\frac{1}{2}$

$\frac{1}{2}$

$\frac{1}{2}$

1

35

Let $P(1,6,3)$ be the given point, and let ' L ' be the foot of the perpendicular from ' P ' to the given line AB (as shown in the figure below). The coordinates of a general point on the given line are given by

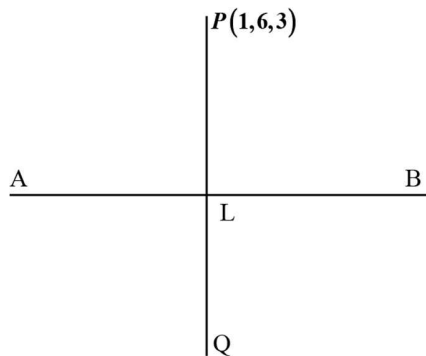

$$\frac{x-0}{1} = \frac{y-1}{2} = \frac{z-2}{3} = \lambda; \lambda \text{ is a scalar, i.e., } x = \lambda, y = 2\lambda + 1 \text{ and } z = 3\lambda + 2$$

Let the coordinates of L be $(\lambda, 2\lambda + 1, 3\lambda + 2)$.

So, direction ratios of PL are $\lambda - 1, 2\lambda + 1 - 6$ and $3\lambda + 2 - 3$, i.e. $\lambda - 1, 2\lambda - 5$ and $3\lambda - 1$.

Direction ratios of the given line are $1, 2$ and 3 , which is perpendicular to PL .

$$\text{Therefore, } (\lambda - 1)1 + (2\lambda - 5)2 + (3\lambda - 1)3 = 0 \Rightarrow 14\lambda - 14 = 0 \Rightarrow \lambda = 1$$

So, coordinates of L are $(1, 3, 5)$.

$\frac{1}{2}$
 $\frac{1}{2}$

1

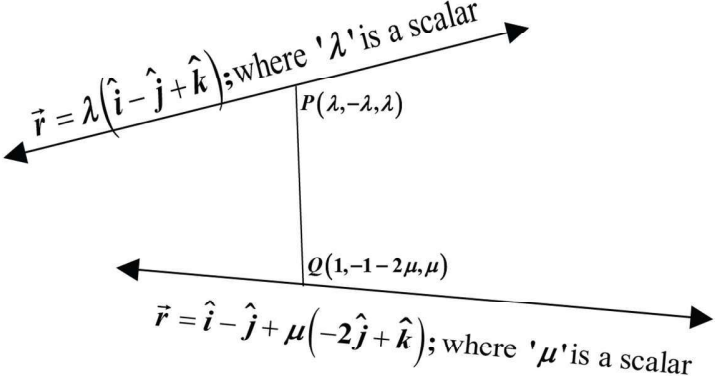
	<p>Let $Q(x_1, y_1, z_1)$ be the image of $P(1, 6, 3)$ in the given line. Then, L is the mid-point of PQ.</p> <p>Therefore, $\frac{(x_1 + 1)}{2} = 1, \frac{(y_1 + 6)}{2} = 3$ and $\frac{(z_1 + 3)}{2} = 5 \Rightarrow x_1 = 1, y_1 = 0$ and $z_1 = 7$</p> <p>Hence, the image of $P(1, 6, 3)$ in the given line is $(1, 0, 7)$.</p> <p>Now, the distance of the point $(1, 0, 7)$ from the y-axis is $\sqrt{1^2 + 7^2} = \sqrt{50}$ units.</p>	<p>1</p> <p>1</p> <p>1</p>
<p>35 OR</p>	<p>Method 1:</p>  <p>Given that equation of lines are</p> <p>$\vec{r} = \lambda(\hat{i} - \hat{j} + \hat{k})$.....(i) and $\vec{r} = \hat{i} - \hat{j} + \mu(-2\hat{j} + \hat{k})$.....(ii)</p> <p>The given lines are non-parallel lines as vectors $\hat{i} - \hat{j} + \hat{k}$ and $-2\hat{j} + \hat{k}$ are not parallel. There is a unique line segment PQ (P lying on line (i) and Q on the other line (ii)), which is at right angles to both the lines. PQ is the shortest distance between the lines. Hence, the shortest possible distance between the aeroplanes = PQ.</p> <p>Let the position vector of the point P lying on the line $\vec{r} = \lambda(\hat{i} - \hat{j} + \hat{k})$ where 'λ' is a scalar, is $\lambda(\hat{i} - \hat{j} + \hat{k})$, for some λ and the position vector of the point Q lying on the line $\vec{r} = \hat{i} - \hat{j} + \mu(-2\hat{j} + \hat{k})$; where '$\mu$' is a scalar, is $\hat{i} + (-1 - 2\mu)\hat{j} + (\mu)\hat{k}$, for some μ.</p> <p>Now, the vector $\overrightarrow{PQ} = \overrightarrow{OQ} - \overrightarrow{OP} = (1 - \lambda)\hat{i} + (-1 - 2\mu + \lambda)\hat{j} + (\mu - \lambda)\hat{k}$; (where '$O$' is the origin), is perpendicular to both the lines, so the vector \overrightarrow{PQ} is perpendicular to both the vectors $\hat{i} - \hat{j} + \hat{k}$ and $-2\hat{j} + \hat{k}$.</p> <p>$\Rightarrow (1 - \lambda).1 + (-1 - 2\mu + \lambda).(-1) + (\mu - \lambda).1 = 0$ &</p> <p>$\Rightarrow (1 - \lambda).0 + (-1 - 2\mu + \lambda).(-2) + (\mu - \lambda).1 = 0$</p> <p>$\Rightarrow 2 + 3\mu - 3\lambda = 0$ & $2 + 5\mu - 3\lambda = 0$</p>	<p>$\frac{1}{2}$</p> <p>$\frac{1}{2}$</p> <p>$\frac{1}{2}$</p> <p>$\frac{1}{2}$</p>

On solving the above equations, we get $\lambda = \frac{2}{3}$ and $\mu = 0$

So, the position vector of the points, at which they should be so that the distance between them is the shortest, are $\frac{2}{3}(\hat{i} - \hat{j} + \hat{k})$ and $\hat{i} - \hat{j}$.

$$\overline{PQ} = \overline{OQ} - \overline{OP} = \frac{1}{3}\hat{i} - \frac{1}{3}\hat{j} - \frac{2}{3}\hat{k} \text{ and } |\overline{PQ}| = \sqrt{\left(\frac{1}{3}\right)^2 + \left(-\frac{1}{3}\right)^2 + \left(-\frac{2}{3}\right)^2} = \sqrt{\frac{2}{3}}$$

The shortest distance = $\sqrt{\frac{2}{3}}$ units.

Method 2:

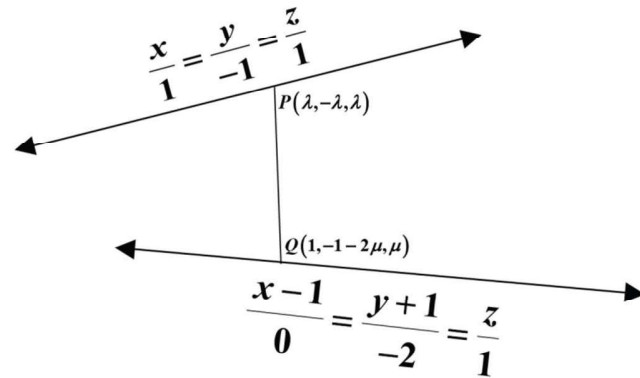

The equation of two given straight lines in the Cartesian form are $\frac{x}{1} = \frac{y}{-1} = \frac{z}{1} \dots\dots (i)$ and

$$\frac{x-1}{0} = \frac{y+1}{-2} = \frac{z}{1} \dots\dots (ii)$$

The lines are not parallel as direction ratios are not proportional. Let P be a point on straight line (i) and Q be a point on straight line (ii) such that line PQ is perpendicular to both of the lines.

Let the coordinates of P be $(\lambda, -\lambda, \lambda)$ and that of Q be $(1, -2\mu - 1, \mu)$; where ' λ ' and ' μ ' are scalars.

Then the direction ratios of the line PQ are $(\lambda - 1, -\lambda + 2\mu + 1, \lambda - \mu)$

Since PQ is perpendicular to straight line (i) , we have,

$$(\lambda - 1).1 + (-\lambda + 2\mu + 1).(-1) + (\lambda - \mu).1 = 0$$

$$\Rightarrow 3\lambda - 3\mu = 2 \dots\dots (iii)$$

Since, PQ is perpendicular to straight line (ii) , we have

$$0.(\lambda - 1) + (-\lambda + 2\mu + 1).(-2) + (\lambda - \mu).1 = 0 \Rightarrow 3\lambda - 5\mu = 2 \dots\dots (iv)$$

Solving (iii) and (iv) , we get $\mu = 0, \lambda = \frac{2}{3}$

Therefore, the Coordinates of P are $\left(\frac{2}{3}, -\frac{2}{3}, \frac{2}{3}\right)$ and that of Q are $(1, -1, 0)$

1

1

1

$\frac{1}{2}$

$\frac{1}{2}$

$\frac{1}{2}$

$\frac{1}{2}$

1

1

1

So, the required shortest distance is $\sqrt{\left(1-\frac{2}{3}\right)^2 + \left(-1+\frac{2}{3}\right)^2 + \left(0-\frac{2}{3}\right)^2} = \sqrt{\frac{2}{3}}$ units.

Section –E

[This section comprises solution of 3 case- study/passage based questions of 4 marks each with two sub parts. Solution of the first two case study questions have three sub parts (i),(ii),(iii) of marks 1,1,2 respectively. Solution of the third case study question has two sub parts of 2 marks each.]

36

Let E_1, E_2, E_3 be the events that Jayant, Sonia and Oliver processed the form, which are clearly pairwise mutually exclusive and exhaustive set of events.

$$\text{Then } P(E_1) = \frac{50}{100} = \frac{5}{10}, P(E_2) = \frac{20}{100} = \frac{1}{5} \text{ and } P(E_3) = \frac{30}{100} = \frac{3}{10}.$$

Also, let E be the event of committing an error.

$$\text{We have, } P(E | E_1) = 0.06, P(E | E_2) = 0.04, P(E | E_3) = 0.03.$$

- (i) The probability that Sonia processed the form and committed an error is given by

$$P(E \cap E_2) = P(E_2) \cdot P(E | E_2) = \frac{1}{5} \times 0.04 = 0.008.$$

- (ii) The total probability of committing an error in processing the form is given by

$$P(E) = P(E_1) \cdot P(E | E_1) + P(E_2) \cdot P(E | E_2) + P(E_3) \cdot P(E | E_3)$$

$$P(E) = \frac{50}{100} \times 0.06 + \frac{20}{100} \times 0.04 + \frac{30}{100} \times 0.03 = 0.047.$$

- (iii) The probability that the form is processed by Jayant given that form has an error is given by

$$P(E_1 | E) = \frac{P(E | E_1) \times P(E_1)}{P(E | E_1) \cdot P(E_1) + P(E | E_2) \cdot P(E_2) + P(E | E_3) \cdot P(E_3)}$$

$$= \frac{0.06 \times \frac{50}{100}}{0.06 \times \frac{50}{100} + 0.04 \times \frac{20}{100} + 0.03 \times \frac{30}{100}} = \frac{30}{47}$$

Therefore, the required probability that the form is **not** processed by Jayant given that form has an

$$\text{error} = P(\overline{E_1} | E) = 1 - P(E_1 | E) = 1 - \frac{30}{47} = \frac{17}{47}.$$

(iii) OR $\sum_{i=1}^3 P(E_i | E) = P(E_1 | E) + P(E_2 | E) + P(E_3 | E) = 1$

Since, sum of the posterior probabilities is 1.

1

1

1

1

1

1

	<p>(We have , $\sum_{i=1}^3 P(E_i E) = P(E_1 E) + P(E_2 E) + P(E_3 E)$</p> $= \frac{P(E \cap E_1) + P(E \cap E_2) + P(E \cap E_3)}{P(E)}$ $= \frac{P((E \cap E_1) \cup (E \cap E_2) \cup (E \cap E_3))}{P(E)}$ as E_i & $E_j; i \neq j$, are mutually exclusive events <p>$= \frac{P(E \cap (E_1 \cup E_2 \cup E_3))}{P(E)} = \frac{P(E \cap S)}{P(E)} = \frac{P(E)}{P(E)} = 1$; 'S' being the sample space)</p>	
<p>37</p>	<p>We have ,</p> $ \vec{F}_1 = \sqrt{6^2 + 0^2} = 6 \text{ kN}, \vec{F}_2 = \sqrt{(-4)^2 + 4^2} = \sqrt{32} = 4\sqrt{2} \text{ kN}, \vec{F}_3 = \sqrt{(-3)^2 + (-3)^2} = \sqrt{18} = 3\sqrt{2} \text{ kN}.$ <p>(i) Magnitude of force of Team A = 6 kN.</p> <p>(ii) Since $\vec{a} + \vec{c} = 3(\hat{i} - \hat{j})$ and $\vec{b} = -4(\hat{i} - \hat{j})$ So, \vec{b} and $\vec{a} + \vec{c}$ are unlike vectors having same initial point and $\vec{b} = 4\sqrt{2}$ & $\vec{a} + \vec{c} = 3\sqrt{2}$ Thus $\vec{F}_2 > \vec{F}_1 + \vec{F}_3$ also \vec{F}_2 and $\vec{F}_1 + \vec{F}_3$ are unlike Hence B will win the game</p> <p>(iii) $\vec{F} = \vec{F}_1 + \vec{F}_2 + \vec{F}_3 = 6\hat{i} + 0\hat{j} - 4\hat{i} + 4\hat{j} - 3\hat{i} - 3\hat{j} = -\hat{i} + \hat{j}$</p> $\therefore \vec{F} = \sqrt{(-1)^2 + (1)^2} = \sqrt{2} \text{ kN}.$ <p style="text-align: center;">OR</p> $\vec{F} = -\hat{i} + \hat{j}$ $\therefore \theta = \pi - \tan^{-1}\left(\frac{1}{1}\right) = \pi - \frac{\pi}{4} = \frac{3\pi}{4};$ where ' θ ' is the angle made by the resultant force with the +ve direction of the x-axis.	<p>1</p> <p>1</p> <p>1</p> <p>1</p> <p>1</p> <p>1</p> <p>1</p>
<p>38</p>	$y = 4x - \frac{1}{2}x^2$ <p>(i) The rate of growth of the plant with respect to the number of days exposed to sunlight is given by $\frac{dy}{dx} = 4 - x$.</p> <p>(ii) Let rate of growth be represented by the function $g(x) = \frac{dy}{dx}$.</p>	<p>2</p>

Now, $g'(x) = \frac{d}{dx}\left(\frac{dy}{dx}\right) = -1 < 0$

$\Rightarrow g(x)$ decreases.

So the rate of growth of the plant decreases for the first three days.

Height of the plant after 2 days is $y = 4 \times 2 - \frac{1}{2}(2)^2 = 6 \text{ cm}$.

1

1

Relation and Function

CASE STUDY 1:

A general election of Lok Sabha is a gigantic exercise. About 911 million people were eligible to vote and voter turnout was about 67%, the highest ever

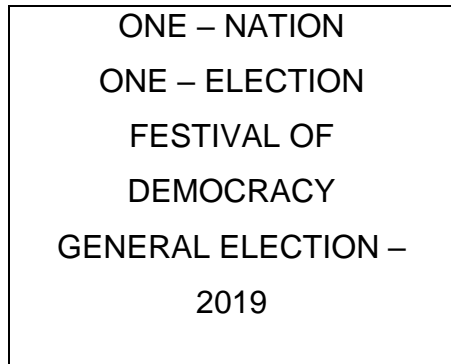

Let I be the set of all citizens of India who were eligible to exercise their voting right in general election held in 2019. A relation 'R' is defined on I as follows:

$R = \{(V1, V2) : V1, V2 \in I \text{ and both use their voting right in general election – 2019}\}$

- Two neighbors X and $Y \in I$. X exercised his voting right while Y did not cast her vote in general election – 2019. Which of the following is true?
 - $(X, Y) \in R$
 - $(Y, X) \in R$
 - $(X, X) \notin R$
 - $(X, Y) \notin R$
- Mr.' X ' and his wife ' W ' both exercised their voting right in general election -2019, Which of the following is true?
 - both (X, W) and $(W, X) \in R$
 - $(X, W) \in R$ but $(W, X) \notin R$
 - both (X, W) and $(W, X) \notin R$
 - $(W, X) \in R$ but $(X, W) \notin R$
- Three friends F_1, F_2 and F_3 exercised their voting right in general election-2019, then which of the following is true?
 - $(F_1, F_2) \in R, (F_2, F_3) \in R$ and $(F_1, F_3) \in R$
 - $(F_1, F_2) \in R, (F_2, F_3) \in R$ and $(F_1, F_3) \notin R$
 - $(F_1, F_2) \in R, (F_2, F_2) \in R$ but $(F_3, F_3) \notin R$
 - $(F_1, F_2) \notin R, (F_2, F_3) \notin R$ and $(F_1, F_3) \notin R$

4. The above defined relation R is _____
 - a. Symmetric and transitive but not reflexive
 - b. Universal relation
 - c. Equivalence relation
 - d. Reflexive but not symmetric and transitive
5. Mr. Shyam exercised his voting right in General Election – 2019, then Mr. Shyam is related to which of the following?
 - a. All those eligible voters who cast their votes
 - b. Family members of Mr. Shyam
 - c. All citizens of India
 - d. Eligible voters of India

ANSWERS

1. (d) $(X,Y) \notin R$
2. (a) both (X,W) and $(W,X) \in R$
3. (a) $(F1,F2) \in R, (F2,F3) \in R$ and $(F1,F3) \in R$
4. (c) Equivalence relation
5. (a) All those eligible voters who cast their votes

CASE STUDY 2

Sherlin and Danju are playing Ludo at home during Covid-19. While rolling the dice, Sherlin's sister Raji observed and noted the possible outcomes of the throw every time belongs to set $\{1,2,3,4,5,6\}$. Let A be the set of players while B be the set of all possible outcomes.



$$A = \{S, D\}, B = \{1,2,3,4,5,6\}$$

1. Let $R : B \rightarrow B$ be defined by $R = \{(x, y) : y \text{ is divisible by } x\}$ is
 - a. Reflexive and transitive but not symmetric
 - b. Reflexive and symmetric and not transitive
 - c. Not reflexive but symmetric and transitive
 - d. Equivalence
2. Raji wants to know the number of functions from A to B. How many number of functions are possible?
 - a. 6^2
 - b. 2^6
 - c. $6!$
 - d. 2^{12}
3. Let R be a relation on B defined by $R = \{(1,2), (2,2), (1,3), (3,4), (3,1), (4,3), (5,5)\}$. Then R is
 - a. Symmetric
 - b. Reflexive
 - c. Transitive
 - d. None of these three
4. Raji wants to know the number of relations possible from A to B. How many numbers of relations are possible?
 - a. 6^2
 - b. 2^6
 - c. $6!$
 - d. 2^{12}
5. Let $R: B \rightarrow B$ be defined by $R = \{(1,1), (1,2), (2,2), (3,3), (4,4), (5,5), (6,6)\}$, then R is
 - a. Symmetric
 - b. Reflexive and Transitive
 - c. Transitive and symmetric
 - d. Equivalence

ANSWERS

1. (a) Reflexive and transitive but not symmetric
2. (a) 6^2
3. (d) None of these three
4. (d) 2^{12}
5. (b) Reflexive and Transitive

CASE STUDY 3:

An organization conducted bike race under 2 different categories-boys and girls. Totally there were 250 participants. Among all of them finally three from Category 1 and two from Category 2 were selected for the final race. Ravi forms two sets B and G with these participants for his college project.

Let $B = \{b_1, b_2, b_3\}$ $G = \{g_1, g_2\}$ where B represents the set of boys selected and G the set of girls who were selected for the final race.



Ravi decides to explore these sets for various types of relations and functions

1. Ravi wishes to form all the relations possible from B to G. How many such relations are possible?
 - a. 2^6
 - b. 2^5
 - c. 0
 - d. 2^3
2. Let $R: B \rightarrow B$ be defined by $R = \{(x, y): x \text{ and } y \text{ are students of same sex}\}$, Then this relation R is _____
 - a. Equivalence
 - b. Reflexive only
 - c. Reflexive and symmetric but not transitive
 - d. Reflexive and transitive but not symmetric
3. Ravi wants to know among those relations, how many functions can be formed from B to G?
 - a. 2^2
 - b. 2^{12}
 - c. 3^2
 - d. 2^3
4. Let $R: B \rightarrow G$ be defined by $R = \{(b_1, g_1), (b_2, g_2), (b_3, g_1)\}$, then R is _____

- a. Injective
 - b. Surjective
 - c. Neither Surjective nor Injective
 - d. Surjective and Injective
5. Ravi wants to find the number of injective functions from B to G. How many numbers of injective functions are possible?
- a. 0
 - b. 2!
 - c. 3!
 - d. 0!

ANSWERS

- 1. (a) 2^6
- 2. (a) Equivalence
- 3. (d) 2^3
- 4. (b) Surjective
- 5. (a) 0

CASE STUDY 5:

Students of Grade 9, planned to plant saplings along straight lines, parallel to each other to one side of the playground ensuring that they had enough play area. Let us assume that they planted one of the rows of the saplings along the line $y = x - 4$. Let L be the set of all lines which are parallel on the ground and R be a relation on L.



Answer the following using the above information.

- 1. Let relation R be defined by $R = \{(L_1, L_2) : L_1 \parallel L_2 \text{ where } L_1, L_2 \in L\}$ then R is _____ relation
 - a. Equivalence
 - b. Only reflexive

- c. Not reflexive
d. Symmetric but not transitive
2. Let $R = \{ (L_1, L_2) : L_1 \perp L_2 \text{ where } L_1, L_2 \in L \}$ which of the following is true?
a. R is Symmetric but neither reflexive nor transitive
b. R is Reflexive and transitive but not symmetric
c. R is Reflexive but neither symmetric nor transitive
d. R is an Equivalence relation
3. The function $f: R \rightarrow R$ defined by $f(x) = x - 4$ is _____
a. Bijective
b. Surjective but not injective
c. Injective but not Surjective
d. Neither Surjective nor Injective
4. Let $f: R \rightarrow R$ be defined by $f(x) = x - 4$. Then the range of $f(x)$ is _____
a. R
b. Z
c. W
d. Q
5. Let $R = \{ (L_1, L_2) : L_1 \text{ is parallel to } L_2 \text{ and } L_1: y = x - 4 \}$ then which of the following can be taken as L_2 ?
a. $2x - 2y + 5 = 0$
b. $2x + y = 5$
c. $2x + 2y + 7 = 0$
d. $x + y = 7$

ANSWERS

1. (a) Equivalence
2. (a) R is Symmetric but neither reflexive nor transitive
3. (a) Bijective
4. (a) R
5. (a) $2x - 2y + 5 = 0$

CASE STUDY 5:



Raji visited the Exhibition along with her family. The Exhibition had a huge swing, which attracted many children. Raji

found that the swing traced the path of a Parabola as given by $y = x^2$.

Answer the following questions using the above information.

1. Let $f: R \rightarrow R$ be defined by $f(x) = x^2$ is _____
 - a. Neither Surjective nor Injective
 - b. Surjective
 - c. Injective
 - d. Bijective
2. Let $f: N \rightarrow N$ be defined by $f(x) = x^2$ is _____
 - a. Surjective but not Injective
 - b. Surjective
 - c. Injective
 - d. Bijective
3. Let $f: \{1,2,3,\dots\} \rightarrow \{1,4,9,\dots\}$ be defined by $f(x) = x^2$ is _____
 - a. Bijective
 - b. Surjective but not Injective
 - c. Injective but Surjective
 - d. Neither Surjective nor Injective
4. Let $f: N \rightarrow R$ be defined by $f(x) = x^2$. Range of the function among the following is _____
 - a. $\{1, 4, 9, 16,\dots\}$
 - b. $\{1, 4, 8, 9, 10,\dots\}$
 - c. $\{1, 4, 9, 15, 16,\dots\}$
 - d. $\{1, 4, 8, 16,\dots\}$
5. The function $f: Z \rightarrow Z$ defined by $f(x) = x^2$ is _____
 - a. Neither Injective nor Surjective

- b. Injective
- c. Surjective
- d. Bijective

ANSWERS

1. (a) Neither Surjective nor Injective
2. (C) Injective
3. (a) Bijective
4. (a) {1, 4, 9, 16,...}
5. (a) Neither Injective nor Surjective

Inverse Trigonometric Function:

CASE STUDY1:

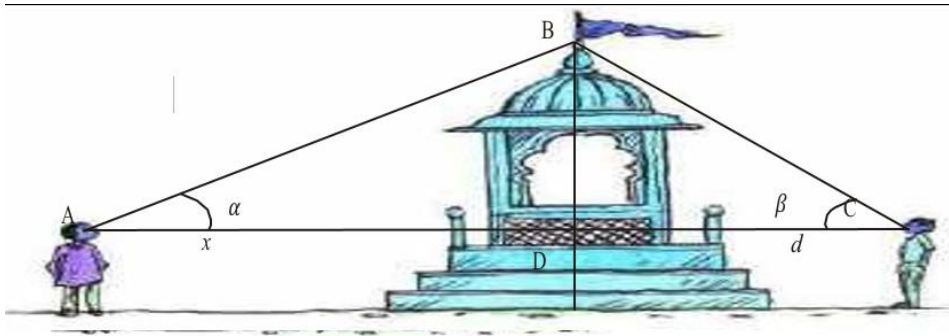

Two men on either side of a temple of 30 meters high observe its top at the angles of elevation α and β respectively. (as shown in the figure above). The distance between the two men is $40\sqrt{3}$ meters and the distance between the first person A and the temple is $30\sqrt{3}$ meters. Based on the above information answer the following:

1. $\angle CAB = \alpha =$
 - a. $\sin^{-1}\left(\frac{2}{\sqrt{3}}\right)$
 - b. $\sin^{-1}\left(\frac{1}{2}\right)$
 - c. $\sin^{-1}(2)$
 - d. $\sin^{-1}\left(\frac{\sqrt{3}}{2}\right)$
2. $\angle CAB = \alpha =$
 - a. $\cos^{-1}\left(\frac{1}{5}\right)$
 - b. $\cos^{-1}\left(\frac{2}{5}\right)$
 - c. $\cos^{-1}\left(\frac{\sqrt{3}}{2}\right)$

d. $\cos^{-1}\left(\frac{4}{5}\right)$

3. $\angle BCA = \beta =$

a. $\tan^{-1}\left(\frac{1}{2}\right)$

b. $\tan^{-1}(2)$

c. $\tan^{-1}\left(\frac{1}{\sqrt{3}}\right)$

d. $\tan^{-1}(\sqrt{3})$

4. $\angle ABC =$

a. $\frac{\pi}{4}$

b. $\frac{\pi}{6}$

c. $\frac{\pi}{2}$

d. $\frac{\pi}{3}$

5. Domain and Range of $\cos^{-1} x =$

a. $(-1, 1), (0, \pi)$

b. $[-1, 1], (0, \pi)$

c. $[-1, 1], [0, \pi]$

d. $(-1, 1), \left[-\frac{\pi}{2}, \frac{\pi}{2}\right]$

ANSWERS

1. (b) $\sin^{-1}\left(\frac{1}{2}\right)$

2. (c) $\cos^{-1}\left(\frac{\sqrt{3}}{2}\right)$

3. (d) $\tan^{-1}(\sqrt{3})$

4. (c) $\frac{\pi}{2}$

5. (c) $[-1, 1], [0, \pi]$

CASE STUDY 2:

The Government of India is planning to fix a hoarding board at the face of a building on the road of a busy market for awareness on COVID-19 protocol. Ram, Robert and Rahim are the three engineers who are working on this project. "A" is considered to be a person viewing the hoarding board 20 metres away from the building, standing at the edge of a pathway nearby. Ram, Robert and Rahim suggested to the firm to place the hoarding board at three different locations namely C, D and E. "C" is at the height of 10 metres from the

ground level. For the viewer A, the angle of elevation of “D” is double the angle of elevation of “C” The angle of elevation of “E” is triple the angle of elevation of “C” for the same viewer. Look at the figure given and based on the above information answer the following:

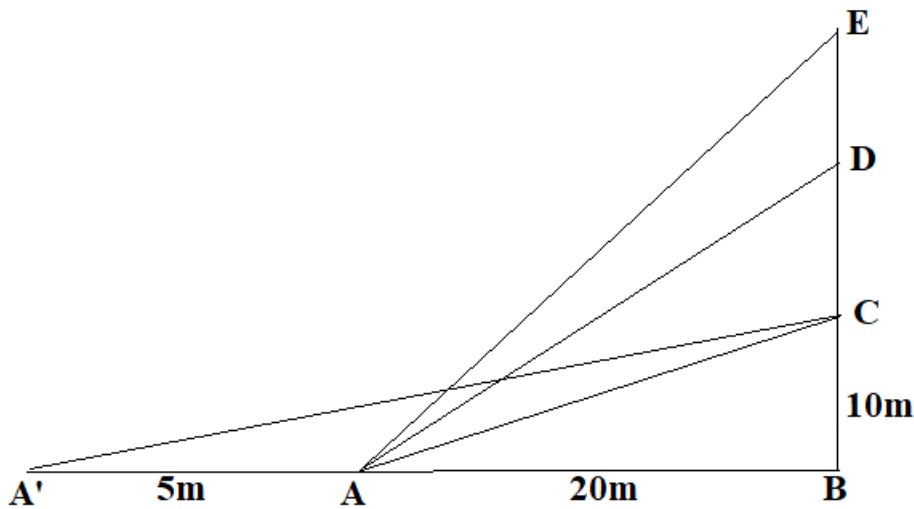

1. Measure of $\angle CAB =$

- a. $\tan^{-1}(2)$
- b. $\tan^{-1}\left(\frac{1}{2}\right)$
- c. $\tan^{-1}(1)$
- d. $\tan^{-1}(3)$

2. Measure of $\angle DAB =$

- a. $\tan^{-1}\left(\frac{3}{4}\right)$
- b. $\tan^{-1}(3)$
- c. $\tan^{-1}\left(\frac{4}{3}\right)$
- d. $\tan^{-1}(4)$

3. Measure of $\angle EAB =$

- a. $\tan^{-1}(11)$
- b. $\tan^{-1} 3$
- c. $\tan^{-1}\left(\frac{2}{11}\right)$
- d. $\tan^{-1}\left(\frac{11}{2}\right)$

4. A' is another viewer standing on the same line of observation across the road. If the width of the road is 5 meters, then the difference between $\angle CAB$ and $\angle CA'B$ is

- a. $\tan^{-1}(1/2)$

b. $\tan^{-1}(1/8)$

c. $\tan^{-1}\left(\frac{2}{5}\right)$

d. $\tan^{-1}\left(\frac{11}{21}\right)$

5. Domain and Range of $\tan^{-1} x =$

a. $R^+, \left(-\frac{\pi}{2}, \frac{\pi}{2}\right)$

b. $R^-, \left(-\frac{\pi}{2}, \frac{\pi}{2}\right)$

c. $R, \left(-\frac{\pi}{2}, \frac{\pi}{2}\right)$

d. $R, \left(0, \frac{\pi}{2}\right)$

ANSWERS

1. (b) $\tan^{-1}\left(\frac{1}{2}\right)$

2. (c) $\tan^{-1}\left(\frac{4}{3}\right)$

3. (d) $\tan^{-1}\left(\frac{11}{2}\right)$

4. (b) $\tan^{-1}(1/8)$

5. (c) $R, \left(-\frac{\pi}{2}, \frac{\pi}{2}\right)$

MATRICES

CASE STUDY1:

A manufacture produces three stationery products Pencil, Eraser and Sharpener which he sells in two markets. Annual sales are indicated below



<u>Market</u>	<u>Products (in numbers)</u>		
	<u>Pencil</u>	<u>Eraser</u>	<u>Sharpener</u>
A	10,000	2000	18,000
B	6000	20,000	8,000

If the unit Sale price of Pencil, Eraser and Sharpener are Rs. 2.50, Rs. 1.50 and Rs. 1.00 respectively, and unit cost of the above three commodities are Rs. 2.00, Rs. 1.00 and Rs. 0.50 respectively, then,

Based on the above information answer the following:

1. Total revenue of market A
 - a. Rs. 64,000
 - b. Rs. 60,400
 - c. Rs. 46,000
 - d. Rs. 40600
2. Total revenue of market B
 - a. Rs. 35,000
 - b. Rs. 53,000
 - c. Rs. 50,300
 - d. Rs. 30,500
3. Cost incurred in market A
 - a. Rs. 13,000
 - b. Rs.30,100
 - c. Rs. 10,300
 - d. Rs. 31,000
4. Profit in market A and B respectively are
 - a. (Rs. 15,000, Rs. 17,000)
 - b. (Rs. 17,000, Rs. 15,000)
 - c. (Rs. 51,000, Rs. 71,000)
 - d. (Rs. 10,000, Rs. 20,000)
5. Gross profit in both market
 - a. Rs.23,000
 - b. Rs. 20,300
 - c. Rs. 32,000
 - d. Rs. 30,200

ANSWERS

1. Rs. 46,000
2. Rs. 53,000
3. RS.31,000
4. (Rs.15, 000, Rs.17, 000)
5. Rs. 32,000

CASE STUDY 2:

Amit, Biraj and Chirag were given the task of creating a square matrix of order 2.

Below are the matrices created by them. A, B, C are the matrices created by Amit, Biraj and Chirag respectively.

$$A = \begin{bmatrix} 1 & 2 \\ -1 & 3 \end{bmatrix} \quad B = \begin{bmatrix} 4 & 0 \\ 1 & 5 \end{bmatrix} \quad C = \begin{bmatrix} 2 & 0 \\ 1 & -2 \end{bmatrix}$$

If $a = 4$ and $b = -2$, based on the above information answer the following:

1. Sum of the matrices A, B and C, $A + (B + C)$ is

a. $\begin{bmatrix} 1 & 6 \\ 2 & 7 \end{bmatrix}$

b. $\begin{bmatrix} 6 & 1 \\ 7 & 2 \end{bmatrix}$

c. $\begin{bmatrix} 7 & 2 \\ 1 & 6 \end{bmatrix}$

d. $\begin{bmatrix} 2 & 1 \\ 7 & 6 \end{bmatrix}$

2. $(A^T)^T$ is equal to

a. $\begin{bmatrix} 1 & 2 \\ -1 & 3 \end{bmatrix}$

b. $\begin{bmatrix} 2 & 1 \\ 3 & -1 \end{bmatrix}$

c. $\begin{bmatrix} 1 & -1 \\ 2 & 3 \end{bmatrix}$

d. $\begin{bmatrix} 2 & 3 \\ -1 & 1 \end{bmatrix}$

3. $(bA)^T$ is equal to

a. $\begin{bmatrix} -2 & -4 \\ 2 & -6 \end{bmatrix}$

b. $\begin{bmatrix} -2 & 2 \\ -4 & -6 \end{bmatrix}$

c. $\begin{bmatrix} -2 & 2 \\ -6 & -4 \end{bmatrix}$

d. $\begin{bmatrix} -6 & -2 \\ 2 & 4 \end{bmatrix}$

4. $AC - BC$ is equal to

a. $\begin{bmatrix} -4 & -6 \\ -4 & 4 \end{bmatrix}$

b. $\begin{bmatrix} -4 & -4 \\ 4 & -6 \end{bmatrix}$

c. $\begin{bmatrix} -4 & -4 \\ -6 & 4 \end{bmatrix}$

d. $\begin{bmatrix} -6 & 4 \\ -4 & -4 \end{bmatrix}$

5. $(a + b)B$ is equal to

a. $\begin{bmatrix} 0 & 8 \\ 10 & 2 \end{bmatrix}$

b. $\begin{bmatrix} 2 & 10 \\ 8 & 0 \end{bmatrix}$

c. $\begin{bmatrix} 8 & 0 \\ 2 & 10 \end{bmatrix}$

d. $\begin{bmatrix} 2 & 0 \\ 8 & 10 \end{bmatrix}$

Answers

1. (c) $\begin{bmatrix} 7 & 2 \\ 1 & 6 \end{bmatrix}$

2. (a) $\begin{bmatrix} 1 & 2 \\ -1 & 3 \end{bmatrix}$

3. (b) $\begin{bmatrix} -2 & 2 \\ -4 & -6 \end{bmatrix}$

4. (c) $\begin{bmatrix} -4 & -4 \\ -6 & 4 \end{bmatrix}$

5. (c) $\begin{bmatrix} 8 & 0 \\ 2 & 10 \end{bmatrix}$

CASE STUDY 2:

Three schools DPS, CVC and KVS decided to organize a fair for collecting money for helping the flood victims. They sold handmade fans, mats and plates from recycled material at a cost of Rs. 25, Rs.100 and Rs. 50 each respectively. The numbers of articles sold are given as



School /Article	DPS	CVC	KVS
Handmade fans	40	25	35
Mats	50	40	50
Plates	20	30	40

Based on the information given above, answer the following questions:

- What is the total money (in Rupees) collected by the school DPS?
 - 700
 - 7,000
 - 6;125
 - 7875
- What is the total amount of money (in Rs.) collected by schools CVC and KVS?
 - 14,000
 - 15,725
 - 21,000
 - 13,125
- What is the total amount of money collected by all three schools DPS, CVC and KVS?
 - Rs. 15,775
 - Rs. 14,000
 - Rs. 21,000
 - Rs. 17,125

4. If the number of handmade fans and plates are interchanged for all the schools, then what is the total money collected by all schools?
- Rs. 18,000
 - Rs. 6,750
 - Rs. 5,000
 - Rs. 21,250
5. How many articles (in total) are sold by three schools?
- 230
 - 130
 - 430
 - 330

ANSWERS

- (b) 7000
- (a) 14000
- (c) Rs.21000
- (d) 21250
- (d) 330

CASE STUDY 3:

On her birth day, Seema decided to donate some money to children of an orphanage home. If there were 8 children less, everyone would have got Rs.10 more. However, if there were 16 children more, everyone would have got Rs. 10 less. Let the number of children be x and the amount distributed by Seema for one child be y (in Rs.).



Based on the information given above, answer the following questions:

- The equations in terms x and y are
 - $5x-4y = 40$

$$5x-8y = -80$$

b. $5x-4y = 40$

$$5x-8y = 80$$

c. $5x-4y = 40$

$$5x+8y = -80$$

d. $5x+4y = 40$

$$5x-8y = -80$$

2. Which of the following matrix equations represent the information given above?

1. $\begin{bmatrix} 5 & 4 \\ 5 & 8 \end{bmatrix} \begin{bmatrix} x \\ y \end{bmatrix} = \begin{bmatrix} 40 \\ -80 \end{bmatrix}$

2. $\begin{bmatrix} 5 & -4 \\ 5 & -8 \end{bmatrix} \begin{bmatrix} x \\ y \end{bmatrix} = \begin{bmatrix} 40 \\ 80 \end{bmatrix}$

3. $\begin{bmatrix} 5 & -4 \\ 5 & -8 \end{bmatrix} \begin{bmatrix} x \\ y \end{bmatrix} = \begin{bmatrix} 40 \\ -80 \end{bmatrix}$

4. $\begin{bmatrix} 5 & 4 \\ 5 & -8 \end{bmatrix} \begin{bmatrix} x \\ y \end{bmatrix} = \begin{bmatrix} 40 \\ -80 \end{bmatrix}$

3. The number of children who were given some money by Seema, is

a. 30

b. 40

c. 23

d. 32

4. How much amount is given to each child by Seema?

a. Rs. 32

b. Rs. 30

c. Rs. 62

d. Rs. 26

5. How much amount Seema spends in distributing the money to all the students of the Orphanage?

a. Rs. 609

b. Rs. 960

c. Rs. 906

d. Rs. 690

ANSWERS

1. (a) $5x-4y = 40$

$$5x-8y = -80$$

2. (c) $\begin{bmatrix} 5 & -4 \\ 5 & -8 \end{bmatrix} \begin{bmatrix} x \\ y \end{bmatrix} = \begin{bmatrix} 40 \\ -80 \end{bmatrix}$

3. (d) 32

4. (b) Rs.30

5. (b) Rs.960

CASE STUDY 4:

Two farmers Ramakishan and Gurucharan Singh cultivate only three varieties of rice namely Basmati, Permal and Naura. The sale (in rupees) of these varieties of rice by both the farmers in the month of September and October are given by the following matrices A and B



September sales (in Rupees)

$$A = \begin{bmatrix} 10,000 & 20,000 & 30,000 \\ 50,000 & 30,000 & 10,000 \end{bmatrix} \begin{matrix} \text{Ramakishan} \\ \text{Gurucharan} \end{matrix}$$

October sales (in Rupees)

$$B = \begin{bmatrix} 5,000 & 10,000 & 6,000 \\ 20,000 & 10,000 & 10,000 \end{bmatrix} \begin{matrix} \text{Ramakishan} \\ \text{Gurucharan} \end{matrix}$$

1. The total sales in September and October for each farmer in each variety can be represented as _____..
 - a. A+B
 - b. A-B

c. $A > B$

d. $A < B$

2. What is the value of A_{23} ?

a. 10000

b. 20000

c. 30000

d. 40000

3. The decrease in sales from September to October is given by _____ .

a. $A+B$

b. $A-B$

c. $A > B$

d. $A < B$

4. If Ramkishan receives 2% profit on gross sales, compute his profit for each variety sold in October.

a. Rs. 100, Rs. 200 and Rs. 120

b. Rs. 100, Rs. 200 and Rs. 130

c. Rs. 100, Rs. 220 and Rs. 120

d. Rs. 110, Rs. 200 and Rs. 120

5. If Gurucharan receives 2% profit on gross sales, compute his profit for each variety sold in September.

a. Rs. 100, Rs. 200, Rs. 120

b. Rs. 1000, Rs. 600, Rs. 200

c. Rs. 400, Rs. 200, Rs. 120

d. Rs. 1200, Rs. 200, Rs. 120

ANSWERS

1. (a) $A+B$

2. (a) 10000

3. (b) $A-B$

4. (a) Rs. 100, Rs. 200 and Rs. 120

5. (b) Rs. 1000, Rs. 600, Rs. 200

Determinants

CASE STUDY 1:

Manjit wants to donate a rectangular plot of land for a school in his village. When he was asked to give dimensions of the plot, he told that if its length is decreased by 50 m and breadth is increased by 50m, then its area will remain same, but if length is decreased by 10m and breadth is decreased by 20m, then its area will decrease by 5300 m²

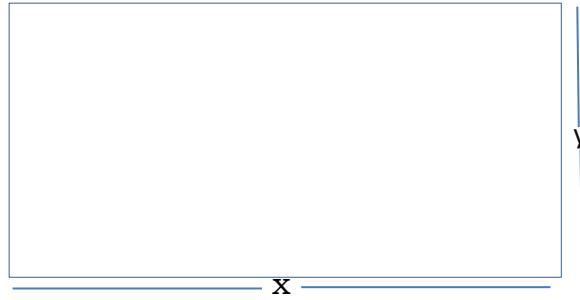

Based on the information given above, answer the following questions:

1. The equations in terms of X and Y are

- a. $x-y=50, 2x-y=550$
- b. $x-y=50, 2x+y=550$
- c. $x + y = 50, 2x + y=550$
- d. $x +y = 50, 2x + y=550$

2. Which of the following matrix equation is represented by the given information

a.
$$\begin{bmatrix} 1 & -1 \\ 2 & 1 \end{bmatrix} \begin{bmatrix} x \\ y \end{bmatrix} = \begin{bmatrix} 50 \\ 550 \end{bmatrix}$$

b.
$$\begin{bmatrix} 1 & 1 \\ 2 & 1 \end{bmatrix} \begin{bmatrix} x \\ y \end{bmatrix} = \begin{bmatrix} 50 \\ 550 \end{bmatrix}$$

c.
$$\begin{bmatrix} 1 & 1 \\ 2 & -1 \end{bmatrix} \begin{bmatrix} x \\ y \end{bmatrix} = \begin{bmatrix} 50 \\ 550 \end{bmatrix}$$

d.
$$\begin{bmatrix} 1 & 1 \\ 2 & 1 \end{bmatrix} \begin{bmatrix} x \\ y \end{bmatrix} = \begin{bmatrix} -50 \\ -550 \end{bmatrix}$$

3. The value of x (length of rectangular field) is

- a. 150m
- b. 400m
- c. 200m

d. 320m

4. The value of y (breadth of rectangular field) is

a. 150m.

b. 200m.

c. 430m.

d. 350m

5. How much is the area of rectangular field?

a. 60000Sq.m.

b. 30000Sq.m.

c. 30000m

d. 3000m

ANSWERS

1. b) $x-y=50$, $2x+y=550$

2. a) $\begin{bmatrix} 1 & -1 \\ 2 & 1 \end{bmatrix} \begin{bmatrix} x \\ y \end{bmatrix} = \begin{bmatrix} 50 \\ 550 \end{bmatrix}$

3. c) 200m

4. a) 150m

5. b) 30000Sq.m

Continuity and Differentiability

CASE STUDY 1:

The Relation between the height of the plant (y in cm) with respect to exposure to sunlight is governed by the following equation $y = 4x - \frac{1}{2}x^2$ where x is the number of days exposed to sunlight.



1. The rate of growth of the plant with respect to sunlight is _____ .

a. $4x - \frac{1}{2}x^2$

b. $4 - x$

c. $x - 4$

d. $x - \frac{1}{2}x^2$

2. What is the number of days it will take for the plant to grow to the maximum height?

- a. 4
- b. 6
- c. 7
- d. 10

3. What is the maximum height of the plant?

- a. 12 cm
- b. 10 cm
- c. 8 cm
- d. 6 cm

4. What will be the height of the plant after 2 days?

- a. 4cm
- b. 6 cm
- c. 8cm
- d. 10cm

5. If the height of the plant is $7/2$ cm, the number of days it has been exposed to the sunlight is _____ .

- a. 2
- b. 3
- c. 4
- d. 1

ANSWERS

- 1. b) $4 - x$
- 2. a) 4
- 3. c) 8cm
- 4. b) 6 cm
- 5. d) 1

CASE STUDY 2:

$P(x) = -5x^2 + 125x + 37500$ is the total profit function of a company, where x is the production of the company.



1. What will be the production when the profit is maximum?
 - a. 37500
 - b. 12.5
 - c. -12.5
 - d. -37500

2. What will be the maximum profit?
 - a. Rs 38,28,125
 - b. Rs 38281.25
 - c. Rs 39,000
 - d. None

3. Check in which interval the profit is strictly increasing .
 - a. $(12.5, \infty)$
 - b. for all real numbers
 - c. for all positive real numbers
 - d. $(0, 12.5)$

4. When the production is 2 units what will be the profit of the company?
 - a. 37500
 - b. 37,730
 - c. 37,770
 - d. None

5. What will be production of the company when the profit is Rs 38250?
 - a. 15
 - b. 30
 - c. 2
 - d. data is not sufficient to find

ANSWERS

1. b) 12.5
2. b) Rs.38281.25
3. d) (0 , 12.5)
4. b) 37,730
5. a) 15

CASE STUDY 3:

A potter made a mud vessel, where the shape of the pot is based on $f(x) = |x - 3| + |x - 2|$, where $f(x)$ represents the height of the pot.



1. When $x > 4$ What will be the height in terms of x ?
 - a. $x - 2$
 - b. $x - 3$
 - c. $2x - 5$
 - d. $5 - 2x$
2. Will the slope vary with x value?
 - a. Yes
 - b. No
3. What is $\frac{dy}{dx}$ at $x = 3$
 - a. 2
 - b. -2
 - c. Function is not differentiable
 - d. 1
4. When the x value lies between (2,3) then the function is
 - a. $2x - 5$
 - b. $5 - 2x$
 - c. 1

d. 5

5. If the potter is trying to make a pot using the function $f(x) = [x]$, will he get a pot or not? Why?

- a. Yes, because it is a continuous function
- b. Yes, because it is not continuous
- c. No, because it is a continuous function
- d. No, because it is not continuous

ANSWERS

- 1. c) $2x - 5$
- 2. a) yes
- 3. c) function is not differentiable
- 4. c) 1
- 5. d) No, because it is not continuous

CASE STUDY4:



The shape of a toy is given as $f(x) = 6(2x^4 - x^2)$. To make the toy beautiful 2 sticks which are perpendicular to each other were placed at a point (2,3), above the toy.

- 1. Which value from the following may be abscissa of critical point?
 - a. $\pm \frac{1}{4}$
 - b. $\pm \frac{1}{2}$
 - c. ± 1
 - d. None
- 2. Find the slope of the normal based on the position of the stick.
 - a. 360
 - b. -360

c. $\frac{1}{360}$

d. $\frac{-1}{360}$

3. What will be the equation of the tangent at the critical point if it passes through (2,3)?

a. $x + 360y = 1082$

b. $y = 360x - 717$

c. $x = 717y + 360$

d. none

4. Find the second order derivative of the function at $x = 5$.

a. 598

b. 1176

c. 3588

d. 3312

5. At which of the following intervals will $f(x)$ be increasing?

a. $(-\infty, -1/2) \cup (1/2, \infty)$

b. $(-1/2, 0) \cup (1/2, \infty)$

c. $(0, 1/2) \cup (1/2, \infty)$

d. $(-\infty, -1/2) \cup (0, 1/2)$

ANSWERS

1. b) $\pm \frac{1}{2}$

2. d) $\frac{-1}{360}$

3. b) $y = 360x - 717$

4. c) 3588

5. b) $(-1/2, 0) \cup (1/2, \infty)$

CASE STUDY 5:

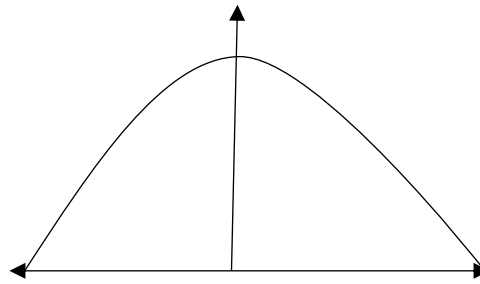
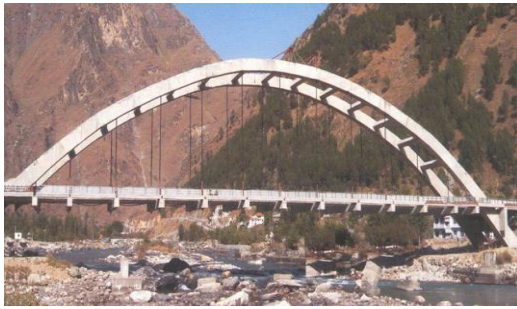

The bridge connects two hills 100 feet apart. The arch on the bridge is in a parabolic form. The highest point on the bridge is 10 feet above the road at the middle of the bridge as seen in the figure.

Based on the information given above, answer the following questions:

1. The equation of the parabola designed on the bridge is

- a. $x^2 = 250y$
- b. $x^2 = -250y$
- c. $y^2 = 250x$
- d. $y^2 = 250y$

2. The value of the integral $\int_{-50}^{50} \frac{x^2}{250} dx$ is

- a. $\frac{1000}{3}$
- b. $\frac{250}{3}$
- c. 1200
- d. 0

3. The integrand of the integral $\int_{-50}^{50} x^2 dx$ is _____ function.

- a. Even
- b. Odd
- c. Neither odd nor even
- d. None

4. The area formed by the curve $x^2 = 250y$, x-axis, $y = 0$ and $y = 10$ is

- a. $\frac{1000\sqrt{2}}{3}$

b. $\frac{4}{3}$

c. $\frac{1000}{3}$

d. 0

5. The area formed between $x^2 = 250y$, y -axis, $y = 2$ and $y = 4$ is

a. $\frac{1000}{3}$

b. 0

c. $\frac{1000\sqrt{2}}{3}$

d. none of these

ANSWERS

1. b) $x^2 = -250y$

2. a) $\frac{1000}{3}$

3. a) Even

4. c) $\frac{1000}{3}$

5. d) none of these

Differential Equation

CASE STUDY 1:

A Veterinary doctor was examining a sick cat brought by a pet lover. When it was brought to the hospital, it was already dead. The pet lover wanted to find its time of death. He took the temperature of the cat at 11.30 pm which was 94.6°F. He took the temperature again after one hour; the temperature was lower than the first observation. It was 93.4°F. The room in which the cat was put is always at 70°F. The normal temperature of the cat is taken as 98.6°F when it was alive. The doctor estimated the time of death using *Newton law of cooling which is governed by the differential equation: $\frac{dT}{dt} \propto (T - 70)$* , where 70°F is the room temperature and T is the temperature of the object at time t.

Substituting the two different observations of T and t made, in the solution of the differential equation $\frac{dT}{dt} = k(T - 70)$ where k is a constant of proportion, time of death is calculated.

1. State the degree of the above given differential equation.
2. Which method of solving a differential equation helped in calculation of the time of death?
 - a. Variable separable method
 - b. Solving Homogeneous differential equation
 - c. Solving Linear differential equation
 - d. all of the above
3. If the temperature was measured 2 hours after 11.30pm, will the time of death change? (Yes/No)
4. The solution of the differential equation $\frac{dT}{dt} = k(T - 70)$ is given by,
 - a. $\log | T - 70 | = kt + C$
 - b. $\log | T - 70 | = \log |kt | + C$
 - c. $T - 70 = kt + C$
 - d. $T - 70 = kt C$
5. If $t = 0$ when T is 72, then the value of c is
 - a. -2
 - b. 0
 - c. 2
 - d. Log 2

ANSWERS

1. Degree is 1
2. (a) Variable separable method
3. No
4. (a) $\log | T - 70 | = kt + C$
5. (d) log 2

CASE STUDY 2:

Polio drops are delivered to 50K children in a district. The rate at which polio drops are given is directly proportional to the number of children who have not been administered the drops. By the end of 2nd week half the children have been given the polio drops. How many will have been given the drops by the end of 3rd week can be estimated using the solution to the differential equation $\frac{dy}{dx} = k(50 - y)$ where x denotes the number of weeks and y the number of children who have been given the drops.

1.State the order of the above given differential equation.

2.Which method of solving a differential equation can be used to solve $\frac{dy}{dx} = k(50 - y)$.?

- a. Variable separable method
- b. Solving Homogeneous differential equation
- c. Solving Linear differential equation
- d. all of the above

3. The solution of the differential equation $\frac{dy}{dx} = k(50 - y)$ is given by,

- a. $\log | 50 - y| = kx + C$
- b. $-\log | 50 - y| = kx + C$
- c. $\log | 50 - y| = \log | kx | + C$
- d. $50 - y = kx + C$

4. The value of c in the particular solution given that $y(0)=0$ and $k = 0.049$ is.

- a. $\log 50$
- b. $\log 1/50$
- c. 50
- d. -50

5. Which of the following solutions may be used to find the number of children who have been given the polio drops?

- a. $y = 50 - e^{kx}$
- b. $y = 50 - e^{-kx}$
- c. $y = 50 (1 - e^{-kx})$
- d. $y = 50 (e^{-kx} - 1)$

ANSWERS:

- 1. Order is 1
- 2. (a) Variable separable method
- 3. (b) $-\log | 50 - y| = kx + C$
- 4. (b) $\log 1/50$
- 5. (c) $y = 50 (1 - e^{-kx})$

Vector Algebra

CASE STUDY1:

Solar Panels have to be installed carefully so that the tilt of the roof, and the direction to the sun, produce the largest possible electrical power in the solar panels.



A surveyor uses his instrument to determine the coordinates of the four corners of a roof where solar panels are to be mounted. In the picture, suppose the points are labelled counter clockwise from the roof corner nearest to the camera in units of meters P_1 (6,8,4), P_2 (21,8,4), P_3 (21,16,10) and

P_4 (6,16,10)

1. What are the components to the two edge vectors defined by $\vec{A} = \text{PV of } P_2 - \text{PV of } P_1$ and $\vec{B} = \text{PV of } P_4 - \text{PV of } P_1$? (where PV stands for position vector)
2. Write the vector in standard notation with \hat{i} , \hat{j} and \hat{k} (where \hat{i} , \hat{j} and \hat{k} are the unit vectors along the three axes).
3. What are the magnitudes of the vectors \vec{A} and \vec{B} and in what units?
4. What are the components to the vector \vec{N} , perpendicular to \vec{A} and \vec{B} and the surface of the roof?
5. What is the magnitude of \vec{N} and its units? The sun is located along the unit vector $\vec{S} = \frac{1}{2} \hat{i} - \frac{6}{7} \hat{j} + \frac{1}{7} \hat{k}$. If the flow of solar energy is given by the vector $\vec{F} = 910 \text{ S}$ in units of watts/meter², what is the dot product of vectors \vec{F} with \vec{N} , and the units for this quantity?
6. What is the angle between vectors \vec{N} and \vec{S} ? What is the elevation angle of the sun above the plane of the roof? ($\text{COS } 51^\circ = 0.629$)

ANSWERS

1. 15, 0, 0 : 0, 8, 6
2. Answer $15\hat{i}+0\hat{j}+0\hat{k}$ Answer 2: $0\hat{i}+8\hat{j}+6\hat{k}$
3. Answer : 15 unit , Answer : $\sqrt{8^2 + 6^2} = \sqrt{64 + 36} = \sqrt{100} = 10$ unit
4. $\vec{N} = \vec{A} \times \vec{B}$
$$N = \begin{vmatrix} \hat{i} & \hat{j} & \hat{k} \\ 15 & 0 & 0 \\ 0 & 8 & 6 \end{vmatrix} = -15(6\hat{j}-8\hat{k}) = -90\hat{j}+120\hat{k}$$
 ; Answer -90 , 120
5. $\sqrt{(-90)^2 + 120^2} = \sqrt{8100 + 14400} = \sqrt{22500} = 150$

Answer of second part: $\vec{F} = 910 (1/2\hat{i} - 6/7\hat{j} + 1/7\hat{k}) = 455\hat{i} - 780\hat{j} + 130\hat{k}$.

The dot product is just $\vec{F} \cdot \vec{N} = 455*(0) - 780*(-90) + 130*120 = \mathbf{85,800 \text{ watts}}$.

From the definition of dot product: $\vec{F} \cdot \vec{N} = |\vec{F}||\vec{N}|\cos\theta$

Then since $|\vec{F}| = 910$ and $|\vec{N}| = 150$ and $\vec{F} \cdot \vec{N} = 85,800$ we have $\cos\theta = (85800/(910 \times 150)) = 0.629$ and so $\theta = \mathbf{\cos^{-1}(0.629)}$ which is $\mathbf{0.8905 \text{ rad}}$ and is $\mathbf{51^\circ}$. (using cosine table)

This is the angle between the normal to the surface and the incident solar rays.

The compliment of this is the elevation of the sun above the plane of the roof or $90 - 51 = 39^\circ$.

CASE STUDY 2:

A class XII student appearing for a competitive examination was asked to attempt the following questions.

Let \vec{a} , \vec{b} , and \vec{c} be three non zero vectors.

1. If \vec{a} and \vec{b} are such that $|\vec{a} + \vec{b}| = |\vec{a} - \vec{b}|$ then
 - a. $\vec{a} \perp \vec{b}$
 - b. $\vec{a} \parallel \vec{b}$
 - c. $\vec{a} = \vec{b}$
 - d. None of these
2. If $\vec{a} = \hat{i} - 2\hat{j}$, $\vec{b} = 2\hat{i} + \hat{j} + 3\hat{k}$ then evaluate $(2\vec{a} + \vec{b}) \cdot [(\vec{a} + \vec{b}) \times (\vec{a} - 2\vec{b})]$
 - a. 0
 - b. 4
 - c. 3
 - d. 2
3. If \vec{a} and \vec{b} are unit vectors and θ be the angle between them then $|\vec{a} - \vec{b}|$ is
 - a. $\sin \frac{\theta}{2}$
 - b. $2 \sin \frac{\theta}{2}$
 - c. $2 \cos \frac{\theta}{2}$
 - d. $\cos \frac{\theta}{2}$
4. Let \vec{a} , \vec{b} and \vec{c} be unit vectors such that $\vec{a} \cdot \vec{b} = \vec{a} \cdot \vec{c} = 0$ and angle between \vec{b} and \vec{c} is $\frac{\pi}{6}$ then $\vec{a} =$
 - a. $2(\vec{b} \times \vec{c})$

b. $-2(\vec{b} \times \vec{c})$

c. $\pm 2(\vec{b} \times \vec{c})$

d. $2(\vec{b} \pm \vec{c})$

5. The area of the parallelogram formed by \vec{a} and \vec{b} as diagonals is

a. 70

b. 35

c. $\sqrt{70}/2$

d. $\sqrt{70}$

ANSWERS

1. (a) $|\vec{a} + \vec{b}|^2 = |\vec{a} - \vec{b}|^2 \Rightarrow 2\vec{a} \cdot \vec{b} = 0, \vec{a} \perp \vec{b}$

2. (a) 0

3. (b) $2 \sin \frac{\theta}{2}$

4. (c) $\pm 2(\vec{b} \times \vec{c})$

5. (c) $\sqrt{70}/2$ sq units

CASE STUDY 3:

A cricket match is organized between two Clubs A and B for which a team from each club is chosen. Remaining players of Club A and Club B are respectively sitting on the plane represented by the equation $\vec{r} \cdot (2\vec{i} - \vec{j} + \vec{k}) = 3$ and $\vec{r} \cdot (\vec{i} + 3\vec{j} + 2\vec{k}) = 8$, to cheer the team of their own clubs.



Based on the above answer the following:

1. The Cartesian equation of the plane on which players of Club A are seated is

a. $2x - y + z = 3$

b. $2x - y + 2z = 3$

c. $2x - y + z = -3$

- d. $x - y + z = 3$
2. The magnitude of the normal to the plane on which players of club B are seated, is
- $\sqrt{15}$
 - $\sqrt{14}$
 - $\sqrt{17}$
 - $\sqrt{20}$
3. The intercept form of the equation of the plane on which players of Club B are seated is
- $\frac{x}{8} + \frac{y}{\frac{8}{3}} + \frac{z}{2} = 1$
 - $\frac{x}{5} + \frac{y}{\frac{8}{3}} + \frac{z}{3} = 1$
 - $\frac{x}{8} + \frac{y}{\frac{8}{3}} + \frac{z}{4} = 1$
 - $\frac{x}{8} + \frac{y}{7} + \frac{z}{2} = 1$
4. Which of the following is a player of Club B?
- Player sitting at (1, 2, 1)
 - Player sitting at (0, 1, 2)
 - Player sitting at (1, 4, 1)
 - Player sitting at (1, 1, 2)
5. The distance of the plane, on which players of Club B are seated, from the origin is
- $\frac{8}{\sqrt{14}}$ units
 - $\frac{6}{\sqrt{14}}$ units
 - $\frac{7}{\sqrt{14}}$ units
 - $\frac{9}{\sqrt{14}}$ units

ANSWERS

- (a) $2x - y + z = 3$
- (b) $\sqrt{14}$
- (c) $\frac{x}{8} + \frac{y}{\frac{8}{3}} + \frac{z}{4} = 1$
- (d) Player sitting at (1, 1, 2)
- (a) $\frac{8}{\sqrt{14}}$ units

CASE STUDY 2:

The Indian coast guard, while patrolling, saw a suspicious boat with people. They were nowhere looking like fishermen. The coast guard were closely observing the movement of the boat for an opportunity to seize the boat. They observed that the boat is moving along a planar surface. At an instant of time, the coordinates of the position of the coast guard helicopter and the boat is $(1, 3, 5)$ and $(2, 5, 3)$ respectively.



Based on the above answer the following:

1. If the line joining the positions of the helicopter and the boat is perpendicular to the plane in which the boat moves, then the equation of the plane is
 - a. $-x + 2y - 2z = 6$
 - b. $x + 2y + 2z = 6$
 - c. $x + 2y - 2z = 6$
 - d. $x - 2y - 2z = 6$
2. If the coast guard decide to shoot the boat at that given instant of time, then what is the distance (in meters) that the bullet has to travel?
 - a. 5m
 - b. 3m
 - c. 6m
 - d. 4m
3. If the coast guard decides to shoot the boat at that given instant of time, when the speed of bullet is 36m/sec, then what is the time taken for the bullet to travel and hit the boat?
 - a. $\frac{1}{8}$ seconds
 - b. $\frac{1}{14}$ seconds

- c. $\frac{1}{10}$ seconds
- d. $\frac{1}{12}$ seconds
4. At that given instant of time, the equation of line passing through the positions of the helicopter and boat is
- a. $\frac{x-1}{1} = \frac{y-3}{2} = \frac{z-5}{-2}$
- b. $\frac{x-1}{2} = \frac{y+3}{1} = \frac{z-5}{-2}$
- c. $\frac{x+1}{-2} = \frac{y-3}{-1} = \frac{z-5}{-2}$
- d. $\frac{x-1}{2} = \frac{y+3}{-1} = \frac{z+5}{2}$
5. At a different instant of time, the boat moves to a different position along the planar surface. What should be the coordinates of the location of the boat if the coast guard shoots the bullet along the line whose equation is $\frac{x}{1} = \frac{y-1}{2} = \frac{z-2}{1}$ for the bullet to hit the boat?
- a. $(\frac{-8}{3}, \frac{19}{3}, \frac{-14}{3})$
- b. $(\frac{8}{3}, \frac{-19}{3}, \frac{-14}{3})$
- c. $(\frac{8}{3}, \frac{-19}{3}, \frac{14}{3})$
- d. none of the above

ANSWERS

1. (c) $x + 2y - 2z = 6$
2. (b) 3m
3. (d) $\frac{1}{12}$ seconds
4. (a) $\frac{x-1}{1} = \frac{y-3}{2} = \frac{z-5}{-2}$
5. (d)_ None of the above

CASE STUDY 3:

The equation of motion of a missile are $x = 3t$, $y = -4t$, $z = t$, where the time 't' is given in seconds, and the distance is measured in kilometres.



Based on the above answer the following:

1. What is the path of the missile?
 - a. Straight line
 - b. Parabola
 - c. Circle
 - d. Ellipse
2. Which of the following points lie on the path of the missile?
 - a. (6, 8, 2)
 - b. (6, -8, -2)
 - c. (6, -8, 2)
 - d. (-6, -8, 2)
3. At what distance will the rocket be from the starting point (0, 0, 0) in 5 seconds?
 - a. $\sqrt{550}$ kms
 - b. $\sqrt{650}$ kms
 - c. $\sqrt{450}$ kms
 - d. $\sqrt{750}$ kms
4. If the position of rocket at a certain instant of time is (5, -8, 10), then what will be the height of the rocket from the ground? (The ground is considered as the $xy - plane$).
 - a. 12 km
 - b. 11 km
 - c. 20 km
 - d. 10 km
5. At a certain instant of time, if the missile is above the sea level, where the equation of the surface of sea is given by $2x + y + 3z = 1$ and the position of the missile at

that instant of time is $(1, 1, 2)$, then the image of the position of the rocket in the sea is

- a. $(\frac{-9}{7}, \frac{-1}{7}, \frac{-10}{7})$
- b. $(\frac{9}{7}, \frac{-1}{7}, \frac{-10}{7})$
- c. $(\frac{-9}{7}, \frac{1}{7}, \frac{-10}{7})$
- d. $(\frac{-9}{7}, \frac{-1}{7}, \frac{10}{7})$

ANSWERS

- 1. (a) Straight line
- 2. (c) $(6, -8, 2)$
- 3. (b) $\sqrt{650}$ kms
- 4. (d) 10 km
- 5. (a) $(\frac{-9}{7}, \frac{-1}{7}, \frac{-10}{7})$

CASE STUDY 4:

Suppose the floor of a hotel is made up of mirror polished Salvatore stone. There is a large crystal chandelier attached to the ceiling of the hotel room. Consider the floor of the hotel room as a plane having the equation $x - y + z = 4$ and the crystal chandelier is suspended at the point $(1, 0, 1)$.



Based on the above answer the following:

- 1. Find the direction ratios of the perpendicular from the point $(1, 0, 1)$ to the plane $x - y + z = 4$.
 - a. $(-1, -1, 1)$
 - b. $(1, -1, -1)$

- c. (-1, -1, -1)
 d. (1, -1, 1)
2. Find the length of the perpendicular from the point (1, 0, 1) to the plane $x - y + z = 4$.
- a. $\frac{2}{\sqrt{3}}$ units
 b. $\frac{4}{\sqrt{3}}$ units
 c. $\frac{6}{\sqrt{3}}$ units
 d. $\frac{8}{\sqrt{3}}$ units
3. The equation of the perpendicular from the point (1, 0, 1) to the plane $x - y + z = 4$ is
- a. $\frac{x-1}{2} = \frac{y+3}{-1} = \frac{z+5}{2}$
 b. $\frac{x-1}{-2} = \frac{y+3}{-1} = \frac{z-5}{2}$
 c. $\frac{x-1}{1} = \frac{y}{-1} = \frac{z-1}{1}$
 d. $\frac{x-1}{2} = \frac{y}{-2} = \frac{z-1}{1}$
4. The equation of the plane parallel to the plane $x - y + z = 4$, which is at a unit distance from the point (1, 0, 1) is
- a. $x - y + z + (2 - \sqrt{3})$
 b. $x - y + z - (2 + \sqrt{3})$
 c. $x - y + z + (2 + \sqrt{3})$
 d. Both (a) and (c)
5. The direction cosine of the normal to the plane $x - y + z = 4$ is
- a. $(\frac{1}{\sqrt{3}}, \frac{-1}{\sqrt{3}}, \frac{-1}{\sqrt{3}})$
 b. $(\frac{1}{\sqrt{3}}, \frac{-1}{\sqrt{3}}, \frac{1}{\sqrt{3}})$
 c. $(\frac{-1}{\sqrt{3}}, \frac{-1}{\sqrt{3}}, \frac{1}{\sqrt{3}})$
 d. $(\frac{-1}{\sqrt{3}}, \frac{-1}{\sqrt{3}}, \frac{-1}{\sqrt{3}})$

ANSWERS

1. (d) (1, -1, 1)
 2. (a) $\frac{2}{\sqrt{3}}$ units
 3. (c) $\frac{x-1}{1} = \frac{y}{-1} = \frac{z-1}{1}$
 4. (d) Both (a) and (c)
 5. (b) $(\frac{1}{\sqrt{3}}, \frac{-1}{\sqrt{3}}, \frac{1}{\sqrt{3}})$

CASE STUDY 5:

A mobile tower stands at the top of a hill. Consider the surface on which the tower stands as a plane having points $A(1, 0, 2)$, $B(3, -1, 1)$ and $C(1, 2, 1)$ on it. The mobile tower is tied with 3 cables from the point A, B and C such that it stands vertically on the ground. The top of the tower is at the point $(2, 3, 1)$ as shown in the figure.

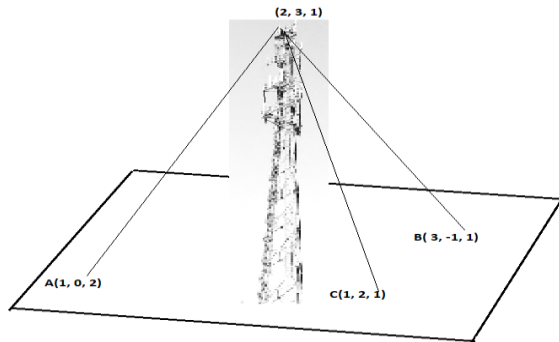

Based on the above answer the following:

- The equation of the plane passing through the points A, B and C is
 - $3x - 2y + 4z = -11$
 - $3x + 2y + 4z = 11$
 - $3x - 2y - 4z = 11$
 - $-3x + 2y + 4z = -11$
- The height of the tower from the ground is
 - $\frac{5}{\sqrt{29}}$ units
 - $\frac{7}{\sqrt{29}}$ units
 - $\frac{6}{\sqrt{29}}$ units
 - $\frac{8}{\sqrt{29}}$ units
- The equation of the perpendicular line drawn from the top of the tower to the ground is
 - $\frac{x-1}{2} = \frac{y+3}{1} = \frac{z-5}{-2}$
 - $\frac{x-2}{-3} = \frac{y-3}{2} = \frac{z-1}{-4}$
 - $\frac{x-2}{3} = \frac{y-3}{2} = \frac{z-1}{4}$
 - $\frac{x+1}{-2} = \frac{y+3}{-1} = \frac{z-5}{2}$

4. The coordinates of the foot of the perpendicular drawn from the top of the tower to the ground are
- $(\frac{43}{29}, \frac{-77}{29}, \frac{-9}{29})$
 - $(\frac{9}{7}, \frac{-1}{7}, \frac{-10}{7})$
 - $(\frac{-43}{29}, \frac{77}{29}, \frac{-9}{29})$
 - $(\frac{43}{29}, \frac{77}{29}, \frac{9}{29})$
5. The area of ΔABC is
- $\frac{\sqrt{29}}{4}$ sq. units
 - $\frac{\sqrt{29}}{2}$ sq. units
 - $\frac{\sqrt{39}}{2}$ sq. units
 - $\frac{\sqrt{39}}{4}$ sq. units

ANSWERS

- (b) $3x + 2y + 4z = 11$
- (a) $\frac{5}{\sqrt{29}}$ units
- (c) $\frac{x-2}{3} = \frac{y-3}{2} = \frac{z-1}{4}$
- (d) $(\frac{43}{29}, \frac{77}{29}, \frac{9}{29})$
- (b) $\frac{\sqrt{29}}{2}$ sq. units

Probability

CASE STUDY 1:

A coach is training 3 players. He observes that the player A can hit a target 4 times in 5 shots, player B can hit 3 times in 4 shots and the player C can hit 2 times in 3 shots



From this situation answer the following:

- Let the target is hit by A, B: the target is hit by B and, C: the target is hit by A and C.
Then, the probability that A, B and, C all will hit, is
 - $4/5$
 - $3/5$
 - $2/5$
 - $1/5$
- Referring to (i), what is the probability that B, C will hit and A will lose?
 - $1/10$
 - $3/10$
 - $7/10$
 - $4/10$
- With reference to the events mentioned in (i), what is the probability that 'any two of A, B and C will hit?'
 - $1/30$
 - $11/30$
 - $17/30$
 - $13/30$
- What is the probability that 'none of them will hit the target?'
 - $1/30$

- b. $1/60$
- c. $1/15$
- d. $2/15$
- 5. What is the probability that at least one of A, B or C will hit the target?
 - a. $59/60$
 - b. $2/5$
 - c. $3/5$
 - d. $1/60$

Answers:

- 1. (c) $2/5$
- 2. (a) $1/10$
- 3. (d) $13/30$
- 4. (b) $1/60$
- 5. (a) $59/60$

CASE STUDY 2:

The reliability of a COVID PCR test is specified as follows:

Of people having COVID, 90% of the test detects the disease but 10% goes undetected. Of people free of COVID, 99% of the test is judged COVID negative but 1% are diagnosed as showing COVID positive. From a large population of which only 0.1% have COVID, one person is selected at random, given the COVID PCR test, and the pathologist reports him/her as COVID positive.



Based on the above information, answer the following

1. What is the probability of the 'person to be tested as COVID positive' given that 'he is actually having COVID'?
 - a. 0.001
 - b. 0.1
 - c. 0.8
 - d. 0.9
2. What is the probability of the 'person to be tested as COVID positive' given that 'he is actually not having COVID'?
 - a. 0.01
 - b. 0.99
 - c. 0.1
 - d. 0.001
3. What is the probability that the 'person is actually not having COVID'?
 - a. 0.998
 - b. 0.999
 - c. 0.001
 - d. 0.111
4. What is the probability that the 'person is actually having COVID given that 'he is tested as COVID positive'?
 - a. 0.83
 - b. 0.0803
 - c. 0.083
 - d. 0.089
5. What is the probability that the 'person selected will be diagnosed as COVID positive'?
 - a. 0.1089
 - b. 0.01089
 - c. 0.0189
 - d. 0.189

Answers

1. (d) 0.9
2. (a) 0.01
3. (b) 0.999
4. (c) 0.083

5. (b) 0.01089

CASE STUDY 3:

In answering a question on a multiple choice test for class XII, a student either knows the answer or guesses. Let $\frac{3}{5}$ be the probability that he knows the answer and $\frac{2}{5}$ be the probability that he guesses. Assume that a student who guesses at the answer will be correct with probability $\frac{1}{3}$. Let E_1 , E_2 , E be the events that the student knows the answer, guesses the answer and answers correctly respectively.



Based on the above information, answer the following

1. What is the value of $P(E_1)$?
 - a. $\frac{2}{5}$
 - b. $\frac{1}{3}$
 - c. 1
 - d. $\frac{3}{5}$
2. Value of $P(E | E_1)$ is
 - a. $\frac{1}{3}$
 - b. 1
 - c. $\frac{2}{3}$
 - d. 415
3. $\sum_{k=1}^{k=2} P(E|E_k) P(E_k)$ Equals
 - a. $\frac{11}{15}$
 - b. $\frac{4}{15}$
 - c. $\frac{1}{5}$
 - d. 1
4. Value of $\sum_{k=1}^{k=2} P(E_k)$

- a. $1/3$
 - b. $1/5$
 - c. 1
 - d. $3/5$
5. What is the probability that the student knows the answer given that he answered it correctly?
- a. $2/11$
 - b. $5/3$
 - c. $9/11$
 - d. $13/3$

Answers

- 1. (d) $3/5$
- 2. (b) 1
- 3. (a) $11/15$
- 4. (c) 1
- 5. (c) $9/11$

CLASS XII (2023-24)
PHYSICS (THEORY)

Time: 3 hrs.

Max Marks: 70

		No. of Periods	Marks
Unit-I	Electrostatics	26	16
	Chapter-1: Electric Charges and Fields		
	Chapter-2: Electrostatic Potential and Capacitance		
Unit-II	Current Electricity	18	
	Chapter-3: Current Electricity		
Unit-III	Magnetic Effects of Current and Magnetism	25	17
	Chapter-4: Moving Charges and Magnetism		
	Chapter-5: Magnetism and Matter		
Unit-IV	Electromagnetic Induction and Alternating Currents	24	
	Chapter-6: Electromagnetic Induction		
	Chapter-7: Alternating Current		
Unit-V	Electromagnetic Waves	04	18
	Chapter-8: Electromagnetic Waves		
Unit-VI	Optics	30	
	Chapter-9: Ray Optics and Optical Instruments		
	Chapter-10: Wave Optics		
Unit-VII	Dual Nature of Radiation and Matter	8	12
	Chapter-11: Dual Nature of Radiation and Matter		
Unit-VIII	Atoms and Nuclei	15	
	Chapter-12: Atoms		
	Chapter-13: Nuclei		
Unit-IX	Electronic Devices	10	7
	Chapter-14: Semiconductor Electronics: Materials, Devices and Simple Circuits		
Total		160	70

Unit I: Electrostatics**26 Periods****Chapter–1: Electric Charges and Fields**

Electric charges, Conservation of charge, Coulomb's law-force between two- point charges, forces between multiple charges; superposition principle and continuous charge distribution.

Electric field, electric field due to a point charge, electric field lines, electric dipole, electric field due to a dipole, torque on a dipole in uniform electric field.

Electric flux, statement of Gauss's theorem and its applications to find field due to infinitely long straight wire, uniformly charged infinite plane sheet and uniformly charged thin spherical shell (field inside and outside).

Chapter–2: Electrostatic Potential and Capacitance

Electric potential, potential difference, electric potential due to a point charge, a dipole and system of charges; equipotential surfaces, electrical potential energy of a system of two-point charges and of electric dipole in an electrostatic field.

Conductors and insulators, free charges and bound charges inside a conductor. Dielectrics and electric polarization, capacitors and capacitance, combination of capacitors in series and in parallel, capacitance of a parallel plate capacitor with and without dielectric medium between the plates, energy stored in a capacitor (no derivation, formulae only).

Unit II: Current Electricity**18 Periods****Chapter–3: Current Electricity**

Electric current, flow of electric charges in a metallic conductor, drift velocity, mobility and their relation with electric current; Ohm's law, V-I characteristics (linear and non-linear), electrical energy and power, electrical resistivity and conductivity, temperature dependence of resistance, Internal resistance of a cell, potential difference and emf of a cell, combination of cells in series and in parallel, Kirchhoff's rules, Wheatstone bridge.

Unit III: Magnetic Effects of Current and Magnetism

25 Periods

Chapter–4: Moving Charges and Magnetism

Concept of magnetic field, Oersted's experiment.

Biot - Savart law and its application to current carrying circular loop.

Ampere's law and its applications to infinitely long straight wire. Straight solenoid (only qualitative treatment), force on a moving charge in uniform magnetic and electric fields.

Force on a current-carrying conductor in a uniform magnetic field, force between two parallel current-carrying conductors-definition of ampere, torque experienced by a current loop in uniform magnetic field; Current loop as a magnetic dipole and its magnetic dipole moment, moving coil galvanometer- its current sensitivity and conversion to ammeter and voltmeter.

Chapter–5: Magnetism and Matter

Bar magnet, bar magnet as an equivalent solenoid (qualitative treatment only), magnetic field intensity due to a magnetic dipole (bar magnet) along its axis and perpendicular to its axis (qualitative treatment only), torque on a magnetic dipole (bar magnet) in a uniform magnetic field (qualitative treatment only), magnetic field lines.

Magnetic properties of materials- Para-, dia- and ferro - magnetic substances with examples, Magnetization of materials, effect of temperature on magnetic properties.

Unit IV: Electromagnetic Induction and Alternating Currents

24 Periods

Chapter–6: Electromagnetic Induction

Electromagnetic induction; Faraday's laws, induced EMF and current; Lenz's Law, Self and mutual induction.

Chapter–7: Alternating Current

Alternating currents, peak and RMS value of alternating current/voltage; reactance and impedance; LCR series circuit (phasors only), resonance, power in AC circuits, power factor, wattless current.

AC generator, Transformer.

Unit V: Electromagnetic waves

04 Periods

Chapter–8: Electromagnetic Waves

Basic idea of displacement current, Electromagnetic waves, their characteristics, their transverse nature (qualitative idea only).

Electromagnetic spectrum (radio waves, microwaves, infrared, visible, ultraviolet, X-rays, gamma rays) including elementary facts about their uses.

Unit VI: Optics

30 Periods

Chapter–9: Ray Optics and Optical Instruments

Ray Optics: Reflection of light, spherical mirrors, mirror formula, refraction of light, total internal reflection and optical fibers, refraction at spherical surfaces, lenses, thin lens formula, lens maker's formula, magnification, power of a lens, combination of thin lenses in contact, refraction of light through a prism.

Optical instruments: Microscopes and astronomical telescopes (reflecting and refracting) and their magnifying powers.

Chapter–10: Wave Optics

Wave optics: Wave front and Huygen's principle, reflection and refraction of plane wave at a plane surface using wave fronts. Proof of laws of reflection and refraction using Huygen's principle. Interference, Young's double slit experiment and expression for fringe width (No derivation final expression only), coherent sources and sustained interference of light, diffraction due to a single slit, width of central maxima (qualitative treatment only).

Unit VII: Dual Nature of Radiation and Matter

08 Periods

Chapter–11: Dual Nature of Radiation and Matter

Dual nature of radiation, Photoelectric effect, Hertz and Lenard's observations; Einstein's photoelectric equation-particle nature of light.

Experimental study of photoelectric effect

Matter waves-wave nature of particles, de-Broglie relation.

Unit VIII: Atoms and Nuclei

15 Periods

Chapter–12: Atoms

Alpha-particle scattering experiment; Rutherford's model of atom; Bohr model of hydrogen atom, Expression for radius of nth possible orbit, velocity and energy of electron in nth orbit, hydrogen line spectra (qualitative treatment only).

Chapter–13: Nuclei

Composition and size of nucleus, nuclear force

Mass-energy relation, mass defect; binding energy per nucleon and its variation with mass number; nuclear fission, nuclear fusion.

Unit IX: Electronic Devices

10 Periods

Chapter–14: Semiconductor Electronics: Materials, Devices and Simple Circuits

Energy bands in conductors, semiconductors and insulators (qualitative ideas only) Intrinsic and extrinsic semiconductors- p and n type, p-n junction

Semiconductor diode - I-V characteristics in forward and reverse bias, application of junction diode -diode as a rectifier.

PRACTICALS

Total Periods 60

The record to be submitted by the students at the time of their annual examination has to include:

- Record of at least 8 Experiments [with 4 from each section], to be performed by the students.
- Record of at least 6 Activities [with 3 each from section A and section B], to be performed by the students.
- The Report of the project carried out by the students.

Evaluation Scheme

Max. Marks: 30

Time 3 hours

Two experiments one from each section	7+7 Marks
Practical record [experiments and activities]	5 Marks
One activity from any section	3 Marks
Investigatory Project	3 Marks
Viva on experiments, activities and project	5 Marks
Total	30 marks

Experiments

SECTION–A

1. To determine resistivity of two / three wires by plotting a graph for potential difference versus current.
2. To find resistance of a given wire / standard resistor using metre bridge.
3. To verify the laws of combination (series) of resistances using a metre bridge.

OR

To verify the laws of combination (parallel) of resistances using a metre bridge.

4. To determine resistance of a galvanometer by half-deflection method and to find its figure of merit.
5. To convert the given galvanometer (of known resistance and figure of merit) into a voltmeter of desired range and to verify the same.

OR

To convert the given galvanometer (of known resistance and figure of merit) into an ammeter of desired range and to verify the same.

6. To find the frequency of AC mains with a sonometer.

Activities

1. To measure the resistance and impedance of an inductor with or without iron core.
2. To measure resistance, voltage (AC/DC), current (AC) and check continuity of a given circuit using multimeter.
3. To assemble a household circuit comprising three bulbs, three (on/off) switches, a fuse and a power source.
4. To assemble the components of a given electrical circuit.
5. To study the variation in potential drop with length of a wire for a steady current.
6. To draw the diagram of a given open circuit comprising at least a battery, resistor/rheostat, key, ammeter and voltmeter. Mark the components that are not connected in proper order and correct the circuit and also the circuit diagram.

SECTION-B

Experiments

1. To find the value of v for different values of u in case of a concave mirror and to find the focal length.
2. To find the focal length of a convex mirror, using a convex lens.
3. To find the focal length of a convex lens by plotting graphs between u and v or between $1/u$ and $1/v$.
4. To find the focal length of a concave lens, using a convex lens.
5. To determine angle of minimum deviation for a given prism by plotting a graph

between angle of incidence and angle of deviation.

6. To determine refractive index of a glass slab using a travelling microscope.
7. To find the refractive index of a liquid using convex lens and plane mirror.
8. To find the refractive index of a liquid using a concave mirror and a plane mirror.
9. To draw the I-V characteristic curve for a p-n junction diode in forward and reverse bias.

Activities

1. To identify a diode, an LED, a resistor and a capacitor from a mixed collection of such items.
2. Use of multimeter to see the unidirectional flow of current in case of a diode and an LED and check whether a given electronic component (e.g., diode) is in working order.
3. To study effect of intensity of light (by varying distance of the source) on an LDR.
4. To observe refraction and lateral deviation of a beam of light incident obliquely on a glass slab.
5. To observe diffraction of light due to a thin slit.
6. To study the nature and size of the image formed by a (i) convex lens, or (ii) concave mirror, on a screen by using a candle and a screen (for different distances of the candle from the lens/mirror).
7. To obtain a lens combination with the specified focal length by using two lenses from the given set of lenses.

Suggested Investigatory Projects

1. To study various factors on which the internal resistance/EMF of a cell depends.
2. To study the variations in current flowing in a circuit containing an LDR because of a variation in
 - (a) the power of the incandescent lamp, used to 'illuminate' the LDR (keeping all the lamps at a fixed distance).

- (b) the distance of a incandescent lamp (of fixed power) used to 'illuminate' the LDR.
3. To find the refractive indices of (a) water (b) oil (transparent) using a plane mirror, an equiconvex lens (made from a glass of known refractive index) and an adjustable object needle.
 4. To investigate the relation between the ratio of (i) output and input voltage and (ii) number of turns in the secondary coil and primary coil of a self-designed transformer.
 5. To investigate the dependence of the angle of deviation on the angle of incidence using a hollow prism filled one by one, with different transparent fluids.
 6. To estimate the charge induced on each one of the two identical Styrofoam (or pith) balls suspended in a vertical plane by making use of Coulomb's law.
 7. To study the factor on which the self-inductance of a coil depends by observing the effect of this coil, when put in series with a resistor/(bulb) in a circuit fed up by an A.C. source of adjustable frequency.
 8. To study the earth's magnetic field using a compass needle -bar magnet by plotting magnetic field lines and tangent galvanometer.

**Practical Examination for Visually Impaired Students of
Classes XI and XII Evaluation Scheme**

Time 2 hours

Max. Marks: 30

Identification/Familiarity with the apparatus	5 marks
Written test (based on given/prescribed practicals)	10 marks
Practical Record	5 marks
Viva	10 marks
Total	30 marks

General Guidelines

- The practical examination will be of two-hour duration.
- A separate list of ten experiments is included here.
- The written examination in practicals for these students will be conducted at the time of practical examination of all other students.
- The written test will be of 30 minutes duration.
- The question paper given to the students should be legibly typed. It should contain a total of 15 practical skill based very short answer type questions. A student would be required to answer any 10 questions.
- A writer may be allowed to such students as per CBSE examination rules.
- All questions included in the question papers should be related to the listed practicals. Every question should require about two minutes to be answered.
- These students are also required to maintain a practical file. A student is expected to record at least five of the listed experiments as per the specific instructions for each subject. These practicals should be duly checked and signed by the internal examiner.
- The format of writing any experiment in the practical file should include aim, apparatus required, simple theory, procedure, related practical skills, precautions etc.
- Questions may be generated jointly by the external/internal examiners and used for assessment.
- The viva questions may include questions based on basic theory/principle/concept, apparatus/ materials/chemicals required, procedure, precautions, sources of error etc.

Class XII

A. Items for Identification/ familiarity with the apparatus for assessment in practicals (All experiments)

Meter scale, general shape of the voltmeter/ammeter, battery/power supply, connecting wires, standard resistances, connecting wires, voltmeter/ammeter, meter bridge, screw gauge, jockey Galvanometer, Resistance Box, standard Resistance, connecting wires, Potentiometer, jockey, Galvanometer, Lechlanche cell, Daniell cell [simple distinction between the two vis-à-vis their outer (glass and copper) containers], rheostat connecting wires, Galvanometer, resistance box, Plug-in and tapping keys, connecting wires battery/power supply, Diode, Resistor (Wire-wound or carbon ones with two wires connected to two ends), capacitors (one or two types), Inductors, Simple electric/electronic bell, battery/power supply, Plug- in and tapping keys, Convex lens, concave lens, convex mirror, concave mirror, Core/hollow wooden cylinder, insulated wire, ferromagnetic rod, Transformer core, insulated wire.

B. List of Practicals

1. To determine the resistance per cm of a given wire by plotting a graph between voltage and current.
2. To verify the laws of combination (series/parallel combination) of resistances by Ohm's law.
3. To find the resistance of a given wire / standard resistor using a meter bridge.
4. To determine the resistance of a galvanometer by half deflection method.
5. To identify a resistor, capacitor, inductor and diode from a mixed collection of such items.
6. To observe the difference between
 - (i) a convex lens and a concave lens
 - (ii) a convex mirror and a concave mirror and to estimate the likely difference between the power of two given convex /concave lenses.
7. To design an inductor coil and to know the effect of
 - (i) change in the number of turns

(ii) Introduction of ferromagnetic material as its core material on the inductance of the coil.

8. To design a (i) step up (ii) step down transformer on a given core and know the relation between its input and output voltages.

Note: The above practicals may be carried out in an experiential manner rather than recording observations.

Prescribed Books:

1. Physics, Class XI, Part -I and II, Published by NCERT.
2. Physics, Class XII, Part -I and II, Published by NCERT.
3. Laboratory Manual of Physics for class XII Published by NCERT.
4. The list of other related books and manuals brought out by NCERT (consider multimedia also).

Note:

The content indicated in NCERT textbooks as excluded for the year 2023-24 is not to be tested by schools and will not be assessed in the Board examinations 2023-24.

QUESTION PAPER DESIGN

Theory (Class: XI/XII)

Maximum Marks: 70

Duration: 3 hrs.

S No.	Typology of Questions	Total Marks	Approximate Percentage
1	Remembering: Exhibit memory of previously learned material by recalling facts, terms, basic concepts, and answers. Understanding: Demonstrate understanding of facts and ideas by organizing, comparing, translating, interpreting, giving descriptions, and stating main ideas	27	38 %
2	Applying: Solve problems to new situations by applying acquired knowledge, facts, techniques and rules in a different way.	22	32%
3	Analysing : Examine and break information into parts by identifying motives or causes. Make inferences and find evidence to support generalizations Evaluating: Present and defend opinions by making judgments about information, validity of ideas, or quality of work based on a set of criteria. Creating: Compile information together in a different way by combining elements in a new pattern or proposing alternative solutions.	21	30%
	Total Marks	70	100
	Practical	30	
	Gross Total	100	

Note:

The above template is only a sample. Suitable internal variations may be made for generating similar templates keeping the overall weightage to different form of questions and typology of questions same.

For more details kindly refer to Sample Question Paper of class XII for the year 2023- 24 to be published by CBSE at its website.

CLASS : XII

SESSION: 2023-24

CBSE SAMPLE QUESTION PAPER

SUBJECT: PHYSICS (THEORY)

Maximum Marks: 70

Time Allowed: 3 hours.

General Instructions:

- (1) There are 33 questions in all. All questions are compulsory.
- (2) This question paper has five sections: Section A, Section B, Section C, Section D and Section E.
- (3) All the sections are compulsory.
- (4) **Section A** contains sixteen questions, twelve MCQ and four Assertion Reasoning based of 1 mark each, **Section B** contains five questions of two marks each, **Section C** contains seven questions of three marks each, **Section D** contains two case study based questions of four marks each and **Section E** contains three long answer questions of five marks each.
- (5) There is no overall choice. However, an internal choice has been provided in one question in Section B, one question in Section C, one question in each CBQ in Section D and all three questions in Section E. You have to attempt only one of the choices in such questions.
- (6) Use of calculators is not allowed.
- (7) You may use the following values of physical constants where ever necessary
 - i. $c = 3 \times 10^8$ m/s
 - ii. $m_e = 9.1 \times 10^{-31}$ kg
 - iii. $e = 1.6 \times 10^{-19}$ C
 - iv. $\mu_0 = 4\pi \times 10^{-7}$ TmA⁻¹
 - v. $h = 6.63 \times 10^{-34}$ Js
 - vi. $\epsilon_0 = 8.854 \times 10^{-12}$ C²N⁻¹m⁻²
 - vii. Avogadro's number = 6.023×10^{23} per gram mole

SECTION-A

1. Which of the following is **not** the property of an equipotential surface?
 - (a) They do not cross each other.
 - (b) The work done in carrying a charge from one point to another on an equipotential surface is zero.
 - (c) For a uniform electric field, they are concentric spheres.
 - (d) They can be imaginary spheres.

2. An electric dipole placed in an electric field of intensity 2×10^5 N/C at an angle of 30° experiences a torque equal to 4 Nm. The charge on the dipole of dipole length 2 cm is
 - (a) 7 μ C
 - (b) 8 mC
 - (c) 2 mC
 - (d) 5 mC

3. A metallic plate exposed to white light emits electrons. For which of the following colours of light, the stopping potential will be maximum?
 (a) Blue (b) Yellow (c) Red (d) Violet
4. When alpha particles are sent through a thin gold foil, most of them go straight through the foil, because
 (a) alpha particles are positively charged
 (b) the mass of an alpha particle is more than the mass of an electron
 (c) most of the part of an atom is empty space
 (d) alpha particles move with high velocity
5. An electron is moving along positive x-axis in a magnetic field which is parallel to the positive y-axis. In what direction will the magnetic force be acting on the electron?
 (a) Along -x axis (b) Along -z axis
 (c) Along +z axis (d) Along -y axis
6. The relative magnetic permeability of a substance X is slightly less than unity and that of substance Y is slightly more than unity, then
 (a) X is paramagnetic and Y is ferromagnetic
 (b) X is diamagnetic and Y is ferromagnetic
 (c) X and Y both are paramagnetic
 (d) X is diamagnetic and Y is paramagnetic
7. An ammeter of resistance 0.81 ohm reads up to 1 A. The value of the required shunt to increase the range to 10 A is
 (a) 0.9 ohm (b) 0.09 ohm (c) 0.03 ohm (d) 0.3 ohm
8. An electron with angular momentum L moving around the nucleus has a magnetic moment given by
 (a) $e L / 2m$ (b) $e L / 3m$ (c) $e L / 4m$ (d) $e L / m$
9. The large scale transmission of electrical energy over long distances is done with the use of transformers. The voltage output of the generator is stepped-up because of
 (a) reduction of current (b) reduction of current and voltage both
 (c) power loss is cut down (d) (a) and (c) both
10. The diagram below shows the electric field (**E**) and magnetic field (**B**) components of an electromagnetic wave at a certain time and location.



The direction of the propagation of the electromagnetic wave is

- (a) perpendicular to \mathbf{E} and \mathbf{B} and out of plane of the paper
- (b) perpendicular to \mathbf{E} and \mathbf{B} and into the plane of the paper
- (c) parallel and in the same direction as \mathbf{E}
- (d) parallel and in the same direction as \mathbf{B}

11. In a coil of resistance 100Ω a current is induced by changing the magnetic flux through it. The variation of current with time is as shown in the figure. The magnitude of change in flux through coil is

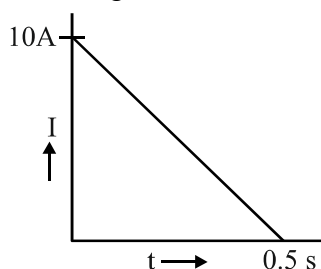

- (a) 200 Wb
- (b) 275 Wb
- (c) 225 Wb
- (d) 250 Wb

12. The energy of an electron in n^{th} orbit of hydrogen atom is $E_n = -13.6/n^2 \text{ eV}$. The negative sign of energy indicates that
- (a) electron is free to move.
 - (b) electron is bound to the nucleus.
 - (c) kinetic energy of electron is equal to potential energy of electron.
 - (d) atom is radiating energy.

For Questions 13 to 16, two statements are given –one labelled Assertion (A) and other labelled Reason (R). Select the correct answer to these questions from the options as given below.

- a) If both Assertion and Reason are true and Reason is correct explanation of Assertion.
- b) If both Assertion and Reason are true but Reason is not the correct explanation of Assertion.
- c) If Assertion is true but Reason is false.
- d) If both Assertion and Reason are false.

13. **Assertion (A):** For the radiation of a frequency greater than the threshold frequency, photoelectric current is proportional to the intensity of the radiation.

Reason (R): Greater the number of energy quanta available, greater is the number of electrons absorbing the energy quanta and greater is number of electrons coming out of the metal.

14. **Assertion (A):** Putting p type semiconductor slab directly in physical contact with n type semiconductor slab cannot form the pn junction.

Reason (R): The roughness at contact will be much more than inter atomic crystal spacing and continuous flow of charge carriers is not possible.

15. **Assertion (A)** : An electron has a higher potential energy when it is at a location associated with a negative value of potential and has a lower potential energy when at a location associated with a positive potential.
Reason (R) : Electrons move from a region of higher potential to a region of lower potential.
16. **Assertion (A)** : Propagation of light through an optical fibre is due to total internal reflection taking place at the core-cladding interface.
Reason (R): Refractive index of the material of the cladding of the optical fibre is greater than that of the core.

SECTION-B

17. (a) Name the device which utilizes unilateral action of a pn diode to convert ac into dc.
 (b) Draw the circuit diagram of full wave rectifier.
18. The wavelength λ of a photon and the de Broglie wavelength of an electron of mass m have the same value. Show that the energy of the photon is $2\lambda mc/h$ times the kinetic energy of the electron, where c and h have their usual meanings.
19. A ray of monochromatic light passes through an equilateral glass prism in such a way that the angle of incidence is equal to the angle of emergence and each of these angles is $3/4$ times the angle of the prism. Determine the angle of deviation and the refractive index of the glass prism.
20. A heating element using nichrome connected to a 230 V supply draws an initial current of 3.2 A which settles after a few seconds to a steady value of 2.8 A. What is the steady temperature of the heating element if the room temperature is $27.0\text{ }^\circ\text{C}$ and the temperature coefficient of resistance of nichrome is $1.70 \times 10^{-4}\text{ }^\circ\text{C}^{-1}$?
21. Show that the least possible distance between an object and its real image in a convex lens is $4f$, where f is the focal length of the lens.

OR

In an astronomical telescope in normal adjustment a straight black line of length L is drawn on the objective lens. The eyepiece forms a real image of this line whose length is l . What is the angular magnification of the telescope?

SECTION-C

22. A given coin has a mass of 3.0 g. Calculate the nuclear energy that would be required to separate all the neutrons and protons from each other. For simplicity assume that the coin is entirely made of ${}_{29}^{63}\text{Cu}$ atoms (of mass 62.92960 u).
 Given $m_p = 1.007825\text{u}$ and $m_n = 1.008665\text{u}$.

23. Charges $(+q)$ and $(-q)$ are placed at the points A and B respectively which are a distance $2L$ apart. C is the midpoint between A and B. What is the work done in moving a charge $+Q$ along the semicircle CRD.

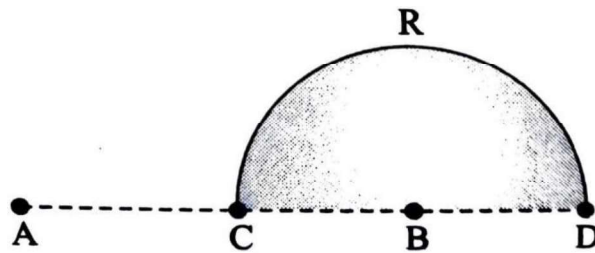

24. The total energy of an electron in the first excited state of the hydrogen atom is about -3.4 eV.
- What is the kinetic energy of the electron in this state?
 - What is the potential energy of the electron in this state?
 - Which of the answers above would change if the choice of the zero of potential energy is changed?
25. A wire of uniform cross-section and resistance 4 ohm is bent in the shape of square ABCD. Point A is connected to a point P on DC by a wire AP of resistance 1 ohm. When a potential difference is applied between A and C, the points B and P are seen to be at the same potential. What is the resistance of the part DP?

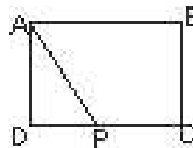

26. The given figure shows a long straight wire of a circular cross-section (radius a) carrying steady current I . The current I is uniformly distributed across this cross-section. Calculate the magnetic field in the region $r < a$ and $r > a$.

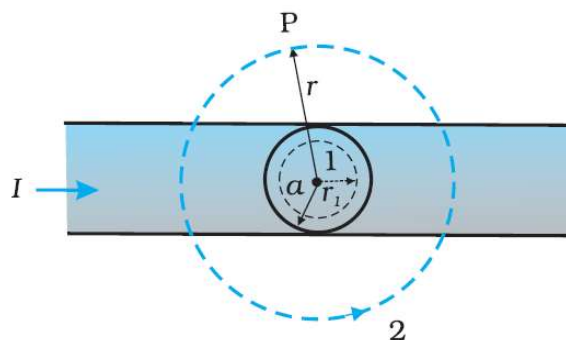

27. Identify the part of the electromagnetic spectrum which:
- produces heating effect,
 - is absorbed by the ozone layer in the atmosphere,
 - is used for studying crystal structure.

Write any one method of the production of each of the above radiations.

28. a. Define mutual inductance and write its SI unit.

- b. Two circular loops, one of small radius r and other of larger radius R , such that $R \gg r$, are placed coaxially with centres coinciding. Obtain the mutual inductance of the arrangement.

OR

Two long straight parallel current carrying conductors are kept 'a' distant apart in air. The direction of current in both the conductors is same. Find the magnitude of force per unit length and direction of the force between them. Hence define one ampere.

SECTION-D

Case Study Based Questions

29. Read the following paragraph and answer the questions that follow.

A semiconductor diode is basically a pn junction with metallic contacts provided at the ends for the application of an external voltage. It is a two terminal device. When an external voltage is applied across a semiconductor diode such that p-side is connected to the positive terminal of the battery and n-side to the negative terminal, it is said to be forward biased. When an external voltage is applied across the diode such that n-side is positive and p-side is negative, it is said to be reverse biased. An ideal diode is one whose resistance in forward biasing is zero and the resistance is infinite in reverse biasing. When the diode is forward biased, it is found that beyond forward voltage called knee voltage, the conductivity is very high. When the biasing voltage is more than the knee voltage the potential barrier is overcome and the current increases rapidly with increase in forward voltage. When the diode is reverse biased, the reverse bias voltage produces a very small current about a few microamperes which almost remains constant with bias. This small current is reverse saturation current.

- i. In the given figure, a diode D is connected to an external resistance $R = 100 \Omega$ and an emf of 3.5 V . If the barrier potential developed across the diode is 0.5 V , the current in the circuit will be:

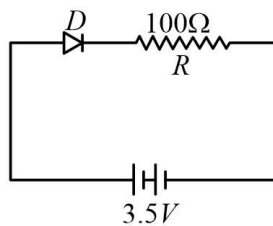

- (a) 40 mA (b) 20 mA (c) 35 mA (d) 30 mA

- ii. In which of the following figures, the pn diode is reverse biased?

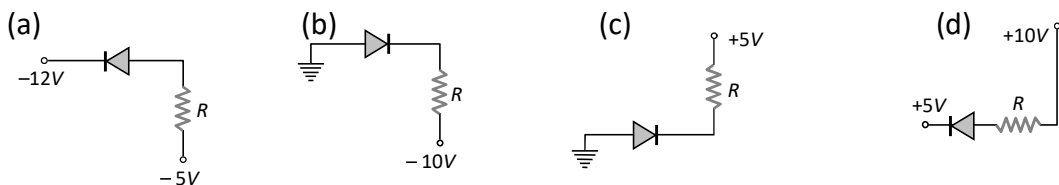

- iii. Based on the V-I characteristics of the diode, we can classify diode as
 (a) bilateral device (b) ohmic device
 (c) non-ohmic device (d) passive element

OR

Two identical PN junctions can be connected in series by three different methods as shown in the figure. If the potential difference in the junctions is the same, then the correct connections will be

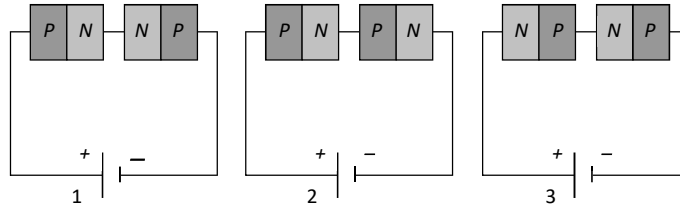

- (a) in the circuits (1) and (2) (b) in the circuits (2) and (3)
 (c) in the circuits (1) and (3) (d) only in the circuit (1)

iv.

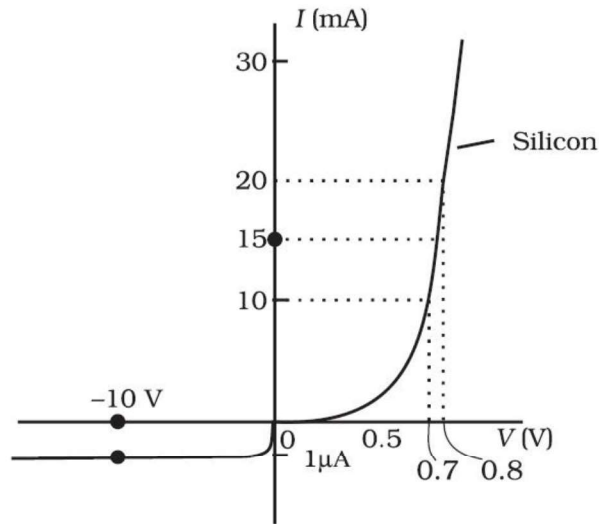

The V-I characteristic of a diode is shown in the figure. The ratio of the resistance of the diode at $I = 15 \text{ mA}$ to the resistance at $V = -10 \text{ V}$ is
 (a) 100 (b) 10^6 (c) 10 (d) 10^{-6}

30. Read the following paragraph and answer the questions that follow.

Types of Lenses and their combination

A convex or converging lens is thicker at the centre than at the edges. It converges a beam of light on refraction through it. It has a real focus. Convex lens is of three types: Double convex lens, Plano convex lens and Concavo-convex lens.

Concave lens is thinner at the centre than at the edges. It diverges a beam of light on refraction through it. It has a virtual focus. Concave lenses are of three types: Double concave lens, Plano concave lens and Convexo-concave lens.

When two thin lenses of focal lengths f_1 and f_2 are placed in contact with each other along their common principal axis, then the two lens system is regarded as a single lens of focal length f and

$$\frac{1}{f} = \frac{1}{f_1} + \frac{1}{f_2}$$

If several thin lenses of focal length f_1, f_2, \dots, f_n are placed in contact, then the effective focal length of the combination is given by

$$\frac{1}{f} = \frac{1}{f_1} + \frac{1}{f_2} + \dots + \frac{1}{f_n}$$

and in terms of power, we can write

$$P = P_1 + P_2 + \dots + P_n$$

The value of focal length and power of a lens must be used with proper sign consideration.

- i. Two thin lenses are kept coaxially in contact with each other and the focal length of the combination is 80 cm. If the focal length of one lens is 20 cm, the focal length of the other would be
(a) -26.7cm (b) 60cm (c) 80cm (d) 30cm

- ii. A spherical air bubble is embedded in a piece of glass. For a ray of light passing through the bubble, it behaves like a
(a) converging lens
(b) diverging lens
(c) mirror
(d) thin plane sheet of glass

- iii. Lens generally used in magnifying glass is
(a) single concave lens
(b) single convex lens
(c) combination of convex lens of lower power and concave lens of lower focal length
(d) Planoconcave lens

- iv. The magnification of an image by a convex lens is positive only when the object is placed
(a) at its focus F
(b) between F and 2F
(c) at 2F
(d) between F and optical centre

OR

A convex lens of 20 cm focal length forms a real image which is three times magnified. The distance of the object from the lens is

- (a) 13.33 cm (b) 14 cm (c) 26.66 cm (d) 25 cm

SECTION-E

31. i. Draw a ray diagram for the formation of image of a point object by a thin double convex lens having radii of curvature R_1 and R_2 . Hence derive lens maker's formula.
- ii. A converging lens has a focal length of 10 cm in air. It is made of a material of refractive index 1.6. If it is immersed in a liquid of refractive index 1.3, find its new focal length.

OR

- i. Define a wavefront. How is it different from a ray?
- ii. Using Huygens's construction of secondary wavelets draw a diagram showing the passage of a plane wavefront from a denser to a rarer medium. Using it verify Snell's law.
- iii. In a double slit experiment using light of wavelength 600nm and the angular width of the fringe formed on a distant screen is 0.1° . Find the spacing between the two slits.
- iv. Write two differences between interference pattern and diffraction pattern.
32. i. Derive an expression for the capacitance of a parallel plate capacitor with air present between the two plates.
- ii. Obtain the equivalent capacitance of the network shown in figure. For a 300 V supply, determine the charge on each capacitor.

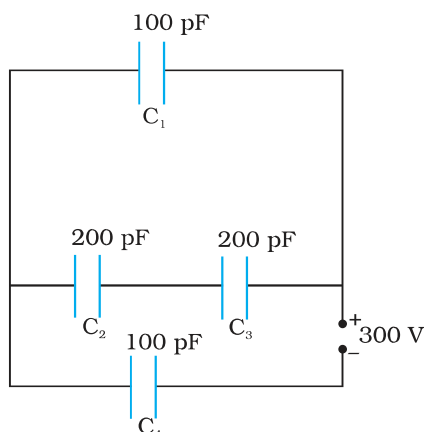

OR

- i. A dielectric slab of thickness 't' is kept between the plates of a parallel plate capacitor with plate separation 'd' ($t < d$). Derive the expression for the capacitance of the capacitor.
- ii. A capacitor of capacity C_1 is charged to the potential of V_0 . On disconnecting with the battery, it is connected with an uncharged capacitor of capacity C_2 as shown in the adjoining figure. Find the ratio of energies before and after the connection of switch S .

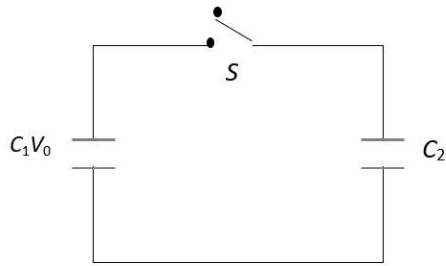

- 33.a.** Draw graphs showing the variations of inductive reactance and capacitive reactance with frequency of applied ac source.
- b.** Draw the phasor diagram for a series LRC circuit connected to an AC source.
- c.** When an alternating voltage of 220V is applied across a device X, a current of 0.25A flows which lags behind the applied voltage in phase by $\pi/2$ radian. If the same voltage is applied across another device Y, the same current flows but now it is in phase with the applied voltage.
- (i) Name the devices X and Y.
- (ii) Calculate the current flowing in the circuit when the same voltage is applied across the series combination of X and Y.

OR

- a.** A series LCR circuit is connected to an ac source. Using the phasor diagram, derive the expression for the impedance of the circuit.
- b.** Plot a graph to show the variation of current with frequency of the ac source, explaining the nature of its variation for two different resistances R_1 and R_2 ($R_1 < R_2$) at resonance.

Class: XII Session 2023-24
SUBJECT: PHYSICS(THEORY)
MARKING SCHEME
SECTION A

- A1: c** **1M**
- A2: c** $q = \tau / [(2a) E \sin \theta] = \frac{4}{2 \times 10^{-2} \times 2 \times 10^5 \sin 30^\circ}$ **1M**
 $= 2 \times 10^{-3} \text{ C} = 2 \text{ mC}$
- A3: d** Higher the frequency, greater is the stopping potential **1M**
- A4: c** **1M**
- A5: b** **1M**
- A6: d** **1M**
- A7: b** **1M**

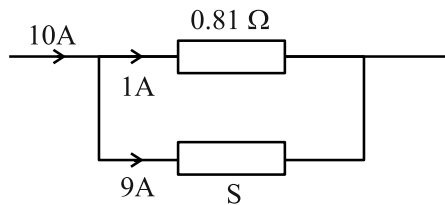

$$9 \times S = 1 \times 0.81$$

$$S = \frac{0.81}{9} = 0.09 \Omega$$

- A8: a** **1M**
- A9: d** **1M**
- A10: a** **1M**
- A11: d** $e = \frac{\Delta \Phi}{\Delta t}, I = \frac{1}{R} \frac{\Delta \Phi}{\Delta t}$ **1M**

$$I \Delta t = \frac{\Delta \Phi}{R} = \text{Area under } I-t \text{ graph, } R = 100 \text{ ohm}$$

$$\therefore \Delta \Phi = 100 \times \frac{1}{2} \times 10 \times 0.5 = 250 \text{ Wb.}$$

- A12: b** **1M**
- A13: a** **1M**
- A14: a** **1M**
- A15: c** **1M**
- Q16: c** **1M**

SECTION B

- A17: (a) Rectifier** **1M**
- (b) Circuit diagram of full wave rectifier** **1M**

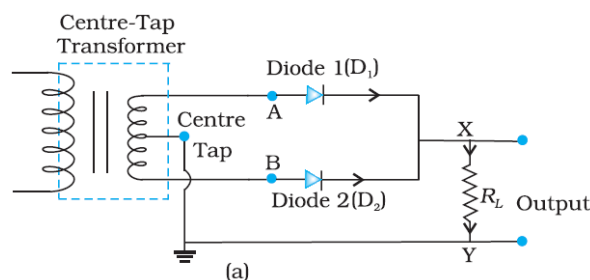

A18: As $\lambda = h / mv$, $v = h / m\lambda$ -----(i) 1/2M
 Energy of photon $E = hc / \lambda$ 1/2M
 & Kinetic energy of electron $K = 1/2 mv^2 = 1/2 mh^2 / m^2 \lambda^2$ -----(ii) 1/2M
 Simplifying equation i & ii we get $E / K = 2\lambda mc / h$ 1/2M

A19: Here angle of prism $A = 60^\circ$, angle of incidence $i =$ angle of emergence e and under this condition angle of deviation is minimum

$$\therefore i = e = \frac{3}{4} A = \frac{3}{4} \times 60^\circ = 45^\circ \text{ and } i + e = A + D,$$

$$\text{hence } D_m = 2i - A = 2 \times 45^\circ - 60^\circ = 30^\circ \quad 1M$$

\therefore Refractive index of glass prism

$$n = \frac{\sin\left(\frac{A + D_m}{2}\right)}{\sin\left(\frac{A}{2}\right)} = \frac{\sin\left(\frac{60^\circ + 30^\circ}{2}\right)}{\sin\left(\frac{60^\circ}{2}\right)} = \frac{\sin 45^\circ}{\sin 30^\circ} = \frac{1/\sqrt{2}}{1/2} = \sqrt{2}. \quad 1M$$

A20: Given: $V = 230 \text{ V}$, $I_0 = 3.2 \text{ A}$, $I = 2.8 \text{ A}$, $T_0 = 27^\circ \text{C}$, $\alpha = 1.70 \times 10^{-4} \text{ }^\circ\text{C}^{-1}$.

Using equation $R = R_0 (1 + \alpha \Delta T)$ 1/2 M

i.e $V/I = \{V/I_0\} [1 + \alpha \Delta T]$ 1/2 M

and solving $\Delta T = 840$, i.e. $T = 840 + 27 = 867^\circ \text{C}$ 1M

A21: Let d be the least distance between object and image for a real image formation.

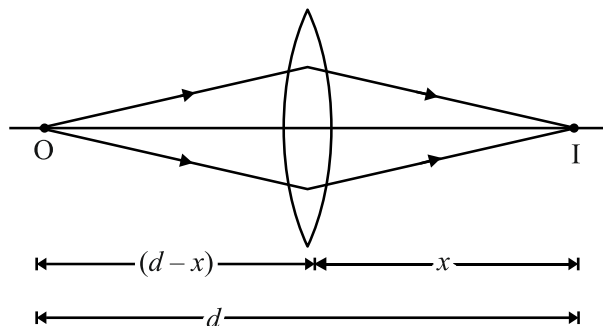

1/2 M

$$\frac{1}{f} = \frac{1}{v} - \frac{1}{u}, \quad \frac{1}{f} = \frac{1}{x} + \frac{1}{d-x} = \frac{d}{x(d-x)} \quad 1/2 M$$

$$fd = xd - x^2, \quad x^2 - dx + fd = 0, \quad x = \frac{d \pm \sqrt{d^2 - 4fd}}{2} \quad 1/2 M$$

$$\text{For real roots of } x, \quad d^2 - 4fd \geq 0 \quad 1/2 M$$

$$d \geq 4f.$$

OR

Let f_o and f_e be the focal length of the objective and eyepiece respectively.

For normal adjustment the distance from objective to eyepiece is $f_o + f_e$.

Taking the line on the objective as object and eyepiece as lens

$$u = -(f_o + f_e) \quad \text{and} \quad f = f_e$$

$$\frac{1}{v} - \frac{1}{[-\{f_o + f_e\}]} = \frac{1}{f_e} \Rightarrow v = \left(\frac{f_o + f_e}{f_o} \right) f_e \quad 1M$$

Linear magnification (eyepiece) = $\frac{v}{u} = \frac{\text{Image size}}{\text{Object size}} = \frac{f_e}{f_o} = \frac{l}{L}$ ½ M

∴ Angular magnification of telescope

$M = \frac{f_o}{f_e} = \frac{L}{l}$ ½ M

SECTION C

A22: Number of atoms in 3 gram of Cu coin = $(6.023 \times 10^{23} \times 3) / 63 = 2.86 \times 10^{22}$ ½ M
 Each atom has 29 Protons & 34 Neutrons

Thus Mass defect $\Delta m = 29 \times 1.00783 + 34 \times 1.00867 - 62.92960 \text{ u} = 0.59225 \text{ u}$ 1M

Nuclear energy required for one atom = $0.59225 \times 931.5 \text{ MeV}$ ½ M

Nuclear energy required for 3 gram of Cu = $0.59225 \times 931.5 \times 2.86 \times 10^{22} \text{ MeV}$
 $= 1.58 \times 10^{25} \text{ MeV}$ 1M

A23:

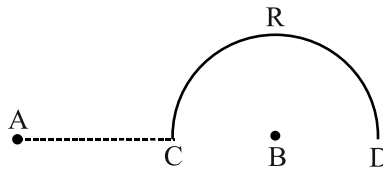

$V_C = 0,$ 1M

$V_D = \frac{1}{4\pi\epsilon_0} \left[\frac{q}{3L} - \frac{q}{L} \right] = \frac{-q}{6\pi\epsilon_0 L}$ 1M

$W = Q [V_D - V_C] = \frac{-Qq}{6\pi\epsilon_0 L}$ 1M

A24: formula $K = -E, U = -2K$ 1M

(a) $K = 3.4 \text{ eV}$ & (b) $U = -6.8 \text{ eV}$ 1M

(c) The kinetic energy of the electron will not change. The value of potential energy and consequently, the value of total energy of the electron will change. 1M

A25:

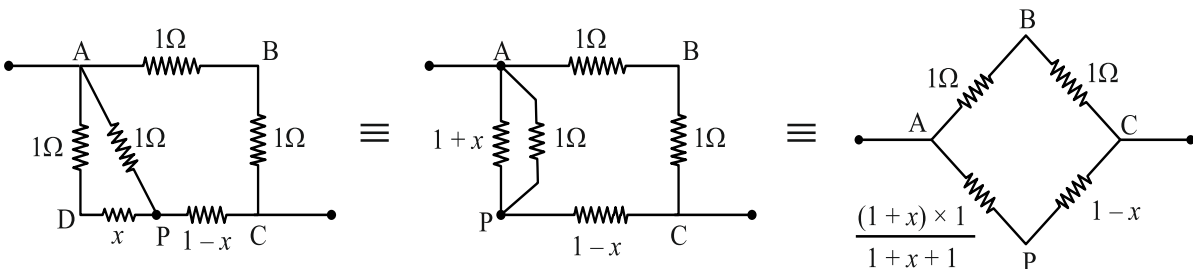

1.5M

As the points B and P are at the same potential, $\frac{1}{1} = \frac{(1+x)}{(2+x)} \Rightarrow x = (\sqrt{2} - 1) \text{ ohm}$ 1.5M

A26:

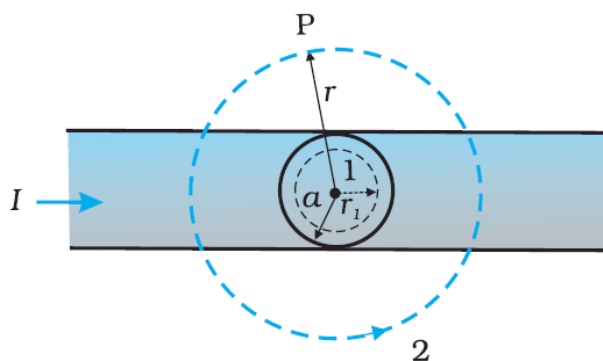

- (a) Consider the case $r > a$. The Amperian loop, labelled 2, is a circle concentric with the cross-section. For this loop, $L = 2\pi r$

Using Ampere circuital Law, we can write,

$$B(2\pi r) = \mu_0 I, \quad B = \frac{\mu_0 I}{2\pi r}, \quad B \propto \frac{1}{r} \quad (r > a) \quad \mathbf{1.5 M}$$

- (b) Consider the case $r < a$. The Amperian loop is a circle labelled 1. For this loop, taking the radius of the circle to be r , $L = 2\pi r$

Now the current enclosed I_e is not I , but is less than this value. Since the current distribution is uniform, the current enclosed is,

$$I_e = I \left(\frac{\pi r^2}{\pi a^2} \right) = \frac{I r^2}{a^2} \quad \text{Using Ampere's law, } B(2\pi r) = \mu_0 \frac{I r^2}{a^2}$$

$$B = \left(\frac{\mu_0 I}{2\pi a^2} \right) r \quad B \propto r \quad (r < a) \quad \mathbf{1.5 M}$$

- A27:** (a) Infrared (b) Ultraviolet (c) X rays $\frac{1}{2} + \frac{1}{2} + \frac{1}{2} M$
 Any one method of the production of each one $\frac{1}{2} + \frac{1}{2} + \frac{1}{2} M$

- A28 (a) :** Definition and S.I. Unit. $\frac{1}{2} + \frac{1}{2} M$

(b)

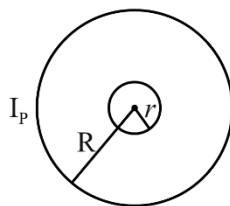

Let a current I_p flow through the circular loop of radius R . The magnetic induction at the centre of the loop is

$$B_p = \frac{\mu_0 I_p}{2R} \quad \mathbf{\frac{1}{2} M}$$

As, $r \ll R$, the magnetic induction B_p may be considered to be constant over the entire cross sectional area of inner loop of radius r . Hence magnetic flux linked with the smaller loop will be

$$\Phi_S = B_p A_S = \frac{\mu_0 I_p}{2R} \pi r^2 \quad \mathbf{\frac{1}{2} M}$$

Also, $\Phi_S = M I_p$ $\mathbf{\frac{1}{2} M}$

$$\therefore M = \frac{\Phi_S}{I_p} = \frac{\mu_0 \pi r^2}{2R} \quad \frac{1}{2} M$$

OR

The magnetic induction B_1 set up by the current I_1 flowing in first conductor at a point somewhere in the middle of second conductor is

$$B_1 = \frac{\mu_0 I_1}{2\pi a} \quad \dots(1) \quad \frac{1}{2} M$$

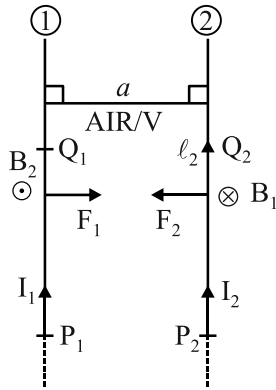

The magnetic force acting on the portion P_2Q_2 of length ℓ_2 of second conductor is

$$F_2 = I_2 \ell_2 B_1 \sin 90^\circ \quad \dots(2)$$

From equation (1) and (2),

$$F_2 = \frac{\mu_0 I_1 I_2 \ell_2}{2\pi a}, \text{ towards first conductor} \quad \frac{1}{2} M$$

$$\frac{F_2}{\ell_2} = \frac{\mu_0 I_1 I_2}{2\pi a} \quad \dots(3)$$

The magnetic induction B_2 set up by the current I_2 flowing in second conductor at a point somewhere in the middle of first conductor is

$$B_2 = \frac{\mu_0 I_2}{2\pi a} \quad \dots(4) \quad \frac{1}{2} M$$

The magnetic force acting on the portion P_1Q_1 of length ℓ_1 of first conductor is

$$F_1 = I_1 \ell_1 B_2 \sin 90^\circ \quad \dots(5)$$

From equation (3) and (5)

$$F_1 = \frac{\mu_0 I_1 I_2 \ell_1}{2\pi a}, \text{ towards second conductor} \quad \frac{1}{2} M$$

$$\frac{F_1}{\ell_1} = \frac{\mu_0 I_1 I_2}{2\pi a} \quad \dots(6)$$

The standard definition of 1A

If $I_1 = I_2 = 1A$

$\ell_1 = \ell_2 = 1m$

$$a = 1m \text{ in V/A then } \frac{F_1}{\ell_1} = \frac{F_2}{\ell_2} = \frac{\mu_0 \times 1 \times 1}{2\pi \times 1} = 2 \times 10^{-7} \text{ N/m}$$

\therefore One ampere is that electric current which when flows in each one of the two infinitely long straight parallel conductors placed 1m apart in vacuum causes each one of them to experience a force of $2 \times 10^{-7} \text{ N/m}$.

1M

SECTION D

A29 (i) d (ii) c (iii) c OR b (iv) d

A30: (i) a (ii) b (iii) b (iv) d OR c

SECTION E

A31: i. DIAGRAM/S : 1M

DERIVATION : 2M

NUMERICAL : 2 M

Lens maker's Formula

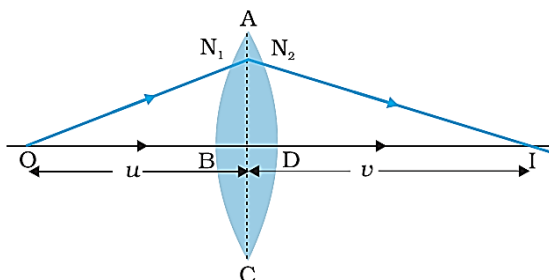

When a ray refracts from a lens (double convex), in above figure, then its image formation can be seen in term of two steps :

Step 1: The first refracting surface forms the image I_1 of the object O

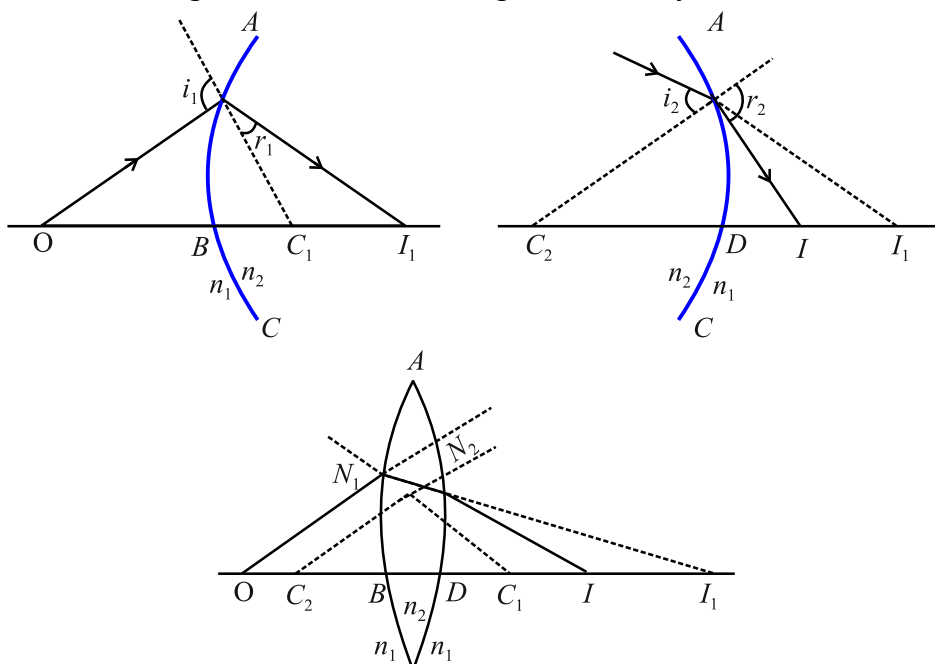

Step 2: The image of object O for first surface acts like a virtual object for the second surface. Now for the first surface ABC, ray will move from rarer to denser medium, then

$$\frac{n_2}{BI_1} + \frac{n_1}{OB} = \frac{n_2 - n_1}{BC_1} \quad \dots(i) \quad \frac{1}{2} M$$

Similarly for the second interface, ADC we can write.

$$\frac{n_1}{DI} - \frac{n_2}{DI_1} = \frac{n_2 - n_1}{DC_2} \quad \dots(ii) \quad \frac{1}{2} M$$

DI_1 is negative as distance is measured against the direction of incident light.

Adding equation (1) and equation (2), we get

$$\frac{n_2}{BI_1} + \frac{n_1}{OB} + \frac{n_1}{DI} - \frac{n_2}{DI_1} = \frac{n_2 - n_1}{BC_1} + \frac{n_2 - n_1}{DC_2}$$

or $\frac{n_1}{DI} + \frac{n_1}{OB} = (n_2 - n_1) \left(\frac{1}{BC_1} + \frac{1}{DC_2} \right) \quad \dots(iii) \quad (\because \text{for thin lens } BI_1 = DI_1)$

Now, if we assume the object to be at infinity *i.e.* $OB \rightarrow \infty$, then its image will form at focus F (with focal length f), *i.e.* ½ M

$DI = f$, thus equation (iii) can be rewritten as

$$\frac{n_1}{f} + \frac{n_1}{\infty} = (n_2 - n_1) \left(\frac{1}{BC_1} + \frac{1}{DC_2} \right)$$

or $\frac{n_1}{f} = (n_2 - n_1) \left(\frac{1}{BC_1} + \frac{1}{DC_2} \right)$... (iv)

Now according to the sign conventions

$$BC_1 = +R_1 \text{ and } DC_2 = -R_2 \quad \dots (v) \quad \text{½ M}$$

Substituting equation (v) in equation (iv), we get

$$\frac{n_1}{f} = (n_2 - n_1) \left(\frac{1}{R_1} - \frac{1}{R_2} \right)$$

$$\frac{1}{f} = \left(\frac{n_2}{n_1} - 1 \right) \left(\frac{1}{R_1} - \frac{1}{R_2} \right)$$

$$\frac{1}{f} = (n_{21} - 1) \left(\frac{1}{R_1} - \frac{1}{R_2} \right)$$

(ii) $\frac{1}{f_a} = (1.6 - 1) \left(\frac{1}{R_1} - \frac{1}{R_2} \right)$... (1) 1M

$\frac{1}{f_\ell} = \left[\frac{1.6}{1.3} - 1 \right] \left(\frac{1}{R_1} - \frac{1}{R_2} \right)$ (2) 1M

From equation (1) and (2)

$$\frac{f_\ell}{f_a} = \left[\frac{0.6}{0.3} \times 1.3 \right] \Rightarrow f_\ell = 2.6 \times 10 \text{ cm} \Rightarrow f_\ell = 26 \text{ cm}$$

OR

(i) A wavefront is defined as a surface of constant phase.

(a) The ray indicates the direction of propagation of wave while the wavefront is the surface of constant phase.

(b) The ray at each point of a wavefront is normal to the wavefront at that point.

1M

(ii) AB: Incident Plane Wave Front & CE is Refracted Wave front . 2M

$$\sin i = BC/AC \quad \& \quad \sin r = AE / AC$$

$$\sin i / \sin r = BC / AE = v_1 / v_2 = \text{constant}$$

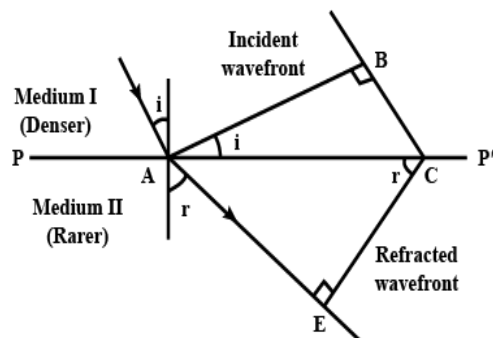

(iii) $\theta = \lambda / a$ i.e. $a = \frac{\lambda}{\theta} = \frac{6 \times 10^{-7}}{0.1 \times \frac{\pi}{180}} = 3.4 \times 10^{-4} \text{ m}$ **1M**

(iv) Two differences between interference pattern and diffraction pattern **1M**

A32: (i) Derivation of the expression for the capacitance **2M**

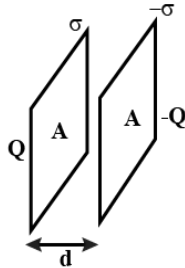

Let the two plates be kept parallel to each other separated by a distance d and cross-sectional area of each plate is A . Electric field by a single thin plate $E = \sigma / 2\epsilon_0$

Total electric field between the plates $E = \sigma / \epsilon_0 = Q / A \epsilon_0$

Potential difference between the plates $V = Ed = [Q / A \epsilon_0] d$.

Capacitance $C = Q / V = A\epsilon_0 / d$

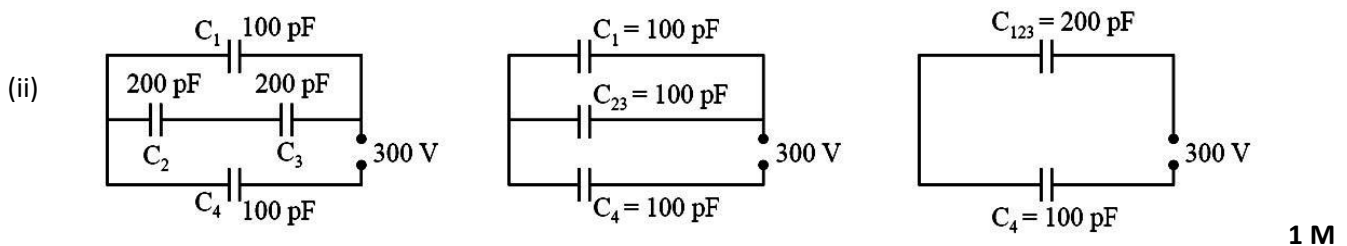

The equivalent capacitance $= \frac{200}{3} \text{ pF}$

charge on $C_4 = \frac{200}{3} \times 10^{-12} \times 300 = 2 \times 10^{-8} \text{ C}$, **½ M**

potential difference across $C_4 = \frac{200 \times 10^{-12} \times 300}{3 \times 100 \times 10^{-12}} = 200 \text{ V}$

potential difference across $C_1 = 300 - 200 = 100 \text{ V}$

charge on $C_1 = 100 \times 10^{-12} \times 100 = 1 \times 10^{-8} \text{ C}$ **½ M**

potential difference across C_2 and C_3 series combination $= 100 \text{ V}$

potential difference across C_2 and C_3 each $= 50 \text{ V}$

charge on C_2 and C_3 each $= 200 \times 10^{-12} \times 50 = 1 \times 10^{-8} \text{ C}$ **½+½ M**

OR

(i) Derivation of the expression for capacitance with dielectric slab ($t < d$) **3M**

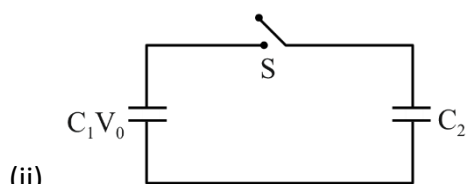

Before the connection of switch S ,

$$\text{Initial energy } U_i = \frac{1}{2}C_1V_0^2 + \frac{1}{2}C_2V_0^2 = \frac{1}{2}(C_1+C_2)V_0^2$$

½ M

After the connection of switch S

$$\text{common potential } V = \frac{C_1V_1 + C_2V_2}{C_1 + C_2} = \frac{C_1V_0}{C_1 + C_2}$$

½ M

$$\text{Final energy } = U_f = \frac{1}{2}(C_1 + C_2) \frac{(C_1V_0)^2}{(C_1 + C_2)^2} = \frac{1}{2} \frac{C_1^2V_0^2}{(C_1 + C_2)}$$

½ M

$$U_f : U_i = C_1 / (C_1 + C_2)$$

½ M

A33:

(a)

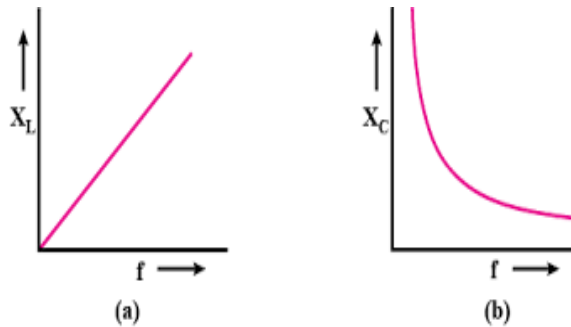

½ + ½ M

(b)

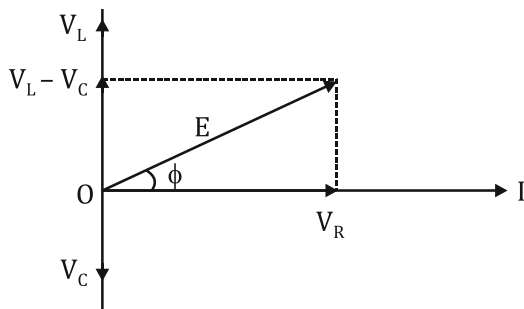

1M

(c)(i) In device X, Current lags behind the voltage by $\pi/2$, X is an inductor

In device Y, Current in phase with the applied voltage, Y is resistor

½ + ½ M

(ii) We are given that

$$0.25 = 220/X_L, X_L = 880\Omega, \text{ Also } 0.25 = 220/R, R = 880\Omega$$

1M

For the series combination of X and Y,

$$\text{Equivalent impedance } Z = 880\sqrt{2}\Omega, I = 0.177\text{ A}$$

1M

OR

a.

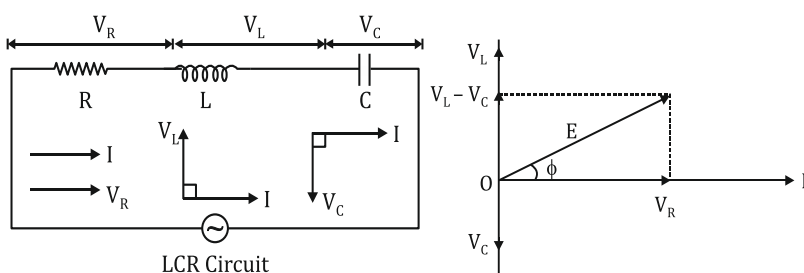

1M

$E = E_0 \sin \omega t$ is applied to a series LCR circuit. Since all three of them are connected in series the current through them is same. But the voltage across each element has a different phase relation with current.

The potential difference V_L , V_C and V_R across L, C and R at any instant is given by

$V_L = IX_L$, $V_C = IX_C$ and $V_R = IR$, where I is the current at that instant.

V_R is in phase with I. V_L leads I by 90° and V_C lags behind I by 90° so the phasor diagram will be as shown

Assuming $V_L > V_C$, the applied emf E which is equal to resultant of potential drop across R, L & C is given as

$$E^2 = I^2 [R^2 + (X_L - X_C)^2]$$

Or $I = \frac{E}{\sqrt{[R^2 + (X_L - X_C)^2]}} = \frac{E}{Z}$, where Z is Impedance. **3M**

Emf leads current by a phase angle ϕ as $\tan \phi = \frac{V_L - V_C}{R} = \frac{X_L - X_C}{R}$

b. The curve (i) is for R_1 and the curve (ii) is for R_2 **1M**

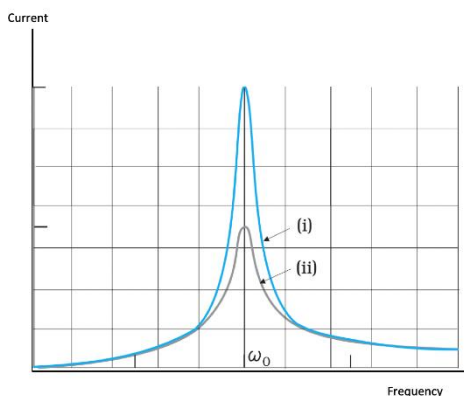

CLASS XII (2023-24) (THEORY)**Time : 3 Hours****70 Marks**

S.No.	Title	No. of Periods	Marks
1	Solutions	10	7
2	Electrochemistry	12	9
3	Chemical Kinetics	10	7
4	d -and f -Block Elements	12	7
5	Coordination Compounds	12	7
6	Haloalkanes and Haloarenes	10	6
7	Alcohols, Phenols and Ethers	10	6
8	Aldehydes, Ketones and Carboxylic Acids	10	8
9	Amines	10	6
10	Biomolecules	12	7
	Total		70

Unit II: Solutions**10 Periods**

Types of solutions, expression of concentration of solutions of solids in liquids, solubility of gases in liquids, solid solutions, Raoult's law, colligative properties - relative lowering of vapour pressure, elevation of boiling point, depression of freezing point, osmotic pressure, determination of molecular masses using colligative properties, abnormal molecular mass, Van't Hoff factor.

Unit III: Electrochemistry**12 Periods**

Redox reactions, EMF of a cell, standard electrode potential, Nernst equation and its application to chemical cells, Relation between Gibbs energy change and EMF of a cell, conductance in electrolytic solutions, specific and molar conductivity, variations of conductivity with concentration, Kohlrausch's Law, electrolysis and law of electrolysis (elementary idea), dry cell-electrolytic cells and Galvanic cells, lead accumulator, fuel cells, corrosion.

Unit IV: Chemical Kinetics**10 Periods**

Rate of a reaction (Average and instantaneous), factors affecting rate of reaction: concentration, temperature, catalyst; order and molecularity of a reaction, rate law and specific rate constant, integrated rate equations and half-life (only for zero and first order reactions), concept of collision theory (elementary idea, no mathematical treatment), activation energy, Arrhenius equation.

Unit VIII: d and f Block Elements**12 Periods**

General introduction, electronic configuration, occurrence and characteristics of transition metals, general trends in properties of the first row transition metals – metallic character, ionization enthalpy, oxidation states, ionic radii, colour, catalytic property, magnetic properties, interstitial compounds, alloy formation, preparation and properties of $K_2Cr_2O_7$ and $KMnO_4$.

Lanthanoids - Electronic configuration, oxidation states, chemical reactivity and lanthanoid contraction and its consequences.

Actinoids - Electronic configuration, oxidation states and comparison with lanthanoids.

Unit IX: Coordination Compounds**12 Periods**

Coordination compounds - Introduction, ligands, coordination number, colour, magnetic properties and shapes, IUPAC nomenclature of mononuclear coordination compounds. Bonding, Werner's theory, VBT, and CFT; structure and stereoisomerism, importance of coordination compounds (in qualitative analysis, extraction of metals and biological system).

Unit X: Haloalkanes and Haloarenes.**10 Periods**

Haloalkanes: Nomenclature, nature of C–X bond, physical and chemical properties, optical rotation mechanism of substitution reactions.

Haloarenes: Nature of C–X bond, substitution reactions (Directive influence of halogen in monosubstituted compounds only).

Uses and environmental effects of - dichloromethane, trichloromethane, tetrachloromethane, iodoform, freons, DDT.

Unit XI: Alcohols, Phenols and Ethers**10 Periods**

Alcohols: Nomenclature, methods of preparation, physical and chemical properties (of primary alcohols only), identification of primary, secondary and tertiary alcohols, mechanism of dehydration, uses with special reference to methanol and ethanol.

Phenols: Nomenclature, methods of preparation, physical and chemical properties, acidic nature of phenol, electrophilic substitution reactions, uses of phenols.

Ethers: Nomenclature, methods of preparation, physical and chemical properties, uses.

Unit XII: Aldehydes, Ketones and Carboxylic Acids**10 Periods**

Aldehydes and Ketones: Nomenclature, nature of carbonyl group, methods of preparation, physical and chemical properties, mechanism of nucleophilic addition, reactivity of alpha hydrogen in aldehydes, uses.

Carboxylic Acids: Nomenclature, acidic nature, methods of preparation, physical and chemical properties; uses.

Unit XIII: Amines**10 Periods**

Amines: Nomenclature, classification, structure, methods of preparation, physical and chemical properties, uses, identification of primary, secondary and tertiary amines.

Diazonium salts: Preparation, chemical reactions and importance in synthetic organic chemistry.

Unit XIV: Biomolecules**12 Periods**

Carbohydrates - Classification (aldoses and ketoses), monosaccharides (glucose and fructose), D-L configuration oligosaccharides (sucrose, lactose, maltose), polysaccharides (starch, cellulose, glycogen); Importance of carbohydrates.

Proteins -Elementary idea of - amino acids, peptide bond, polypeptides, proteins, structure of proteins - primary, secondary, tertiary structure and quaternary structures (qualitative idea only), denaturation of proteins; enzymes. Hormones - Elementary idea excluding structure.

Vitamins - Classification and functions.

Nucleic Acids: DNA and RNA.

PRACTICALS

Evaluation Scheme for Examination	Marks
Volumetric Analysis	08
Salt Analysis	08
Content Based Experiment	06
Project Work	04
Class record and viva	04
Total	30

PRACTICAL SYLLABUS**60Periods**

Micro-chemical methods are available for several of the practical experiments. Wherever possible, such techniques should be used.

A. Surface Chemistry

- (a) Preparation of one lyophilic and one lyophobic sol

Lyophilic sol - starch, egg albumin and gum

Lyophobic sol - aluminium hydroxide, ferric hydroxide, arsenous sulphide.

- (b) Dialysis of sol-prepared in (a) above.
(c) Study of the role of emulsifying agents in stabilizing the emulsion of different oils.

B. Chemical Kinetics

- (a) Effect of concentration and temperature on the rate of reaction between Sodium Thiosulphate and Hydrochloric acid.
(b) Study of reaction rates of any one of the following:
(i) Reaction of Iodide ion with Hydrogen Peroxide at room temperature using different concentration of Iodide ions.
(ii) Reaction between Potassium Iodate, (KIO_3) and Sodium Sulphite: (Na_2SO_3) using starch solution as indicator (clock reaction).

C. Thermochemistry

Any one of the following experiments

- i) Enthalpy of dissolution of Copper Sulphate or Potassium Nitrate.
ii) Enthalpy of neutralization of strong acid (HCl) and strong base (NaOH).
iii) Determination of enthalpy change during interaction (Hydrogen bond formation) between Acetone and Chloroform.

D. Electrochemistry

Variation of cell potential in $Zn/Zn^{2+} || Cu^{2+}/Cu$ with change in concentration of electrolytes ($CuSO_4$ or $ZnSO_4$) at room temperature.

E. Chromatography

- i) Separation of pigments from extracts of leaves and flowers by paper chromatography and determination of R_f values.
ii) Separation of constituents present in an inorganic mixture containing two cations only (constituents having large difference in R_f values to be provided).

F. Preparation of Inorganic Compounds

Preparation of double salt of Ferrous Ammonium Sulphate or Potash Alum. Preparation of Potassium Ferric Oxalate.

G. Preparation of Organic Compounds

Preparation of any one of the following compounds

- i) Acetanilide ii) Di-benzalAcetone iii) p-Nitroacetanilide iv) Aniline yellow or 2 - Naphthol Anilinedye.

H. Tests for the functional groups present in organic compounds:

Unsaturation, alcoholic, phenolic, aldehydic, ketonic, carboxylic and amino (Primary) groups.

I. Characteristic tests of carbohydrates, fats and proteins in pure samples and their detection in given foodstuffs.

J. Determination of concentration/ molarity of KMnO_4 solution by titrating it against a standard solution of:

- i) Oxalic acid,
- ii) Ferrous Ammonium Sulphate

(Students will be required to prepare standard solutions by weighing themselves). K.

Qualitative analysis

Determination of one cation and one anion in a given salt.

Cation : Pb^{2+} , Cu^{2+} , As^{3+} , Al^{3+} , Fe^{3+} , Mn^{2+} , Zn^{2+} , Cu^{2+} , Ni^{2+} , Ca^{2+} , Sr^{2+} , Ba^{2+} , Mg^{2+} , NH_4^+

Anions: $(\text{CO}_3)^{2-}$, S^{2-} , $(\text{SO}_3)^{2-}$, $(\text{NO}_2)^-$, $(\text{SO}_4)^{2-}$, Cl^- , Br^- , I^- , PO_4^{3-} , $(\text{C}_2\text{O}_4)^{2-}$, CH_3COO^- , NO_3^-

(Note: Insoluble salts excluded)

PROJECT

Scientific investigations involving laboratory testing and collecting information from other sources A

few suggested Projects.

- Study of the presence of oxalate ions in guava fruit at different stages of ripening.
- Study of quantity of casein present in different samples of milk.
- Preparation of soybean milk and its comparison with the natural milk with respect to curd formation, effect of temperature, etc.
- Study of the effect of Potassium Bisulphate as food preservative under various conditions (temperature, concentration, time, etc.)
- Study of digestion of starch by salivary amylase and effect of pH and temperature on it.
- Comparative study of the rate of fermentation of following materials: wheat flour, gram flour, potato juice, carrot juice, etc.
- Extraction of essential oils present in Saunf (aniseed), Ajwain (carum), Illaichi (cardamom).
- Study of common food adulterants in fat, oil, butter, sugar, turmeric powder, chilli powder and pepper.
Note: Any other investigatory project, which involves about 10 periods of work, can be chosen with the approval of the teacher.

Practical Examination for Visually Impaired Students of Classes XI and XII Evaluation Scheme

Time Allowed: Two hours

Max. Marks:30

Identification/Familiarity with the apparatus	5 marks
Written test (based on given/prescribed practicals)	10 marks
Practical Record	5 marks
Viva	10 marks
Total	30 marks

General Guidelines

- The practical examination will be of two hour duration.
- A separate list of ten experiments is included here.
- The written examination in practicals for these students will be conducted at the time of practical examination of all other students.
- The written test will be of 30 minutes duration.
- The question paper given to the students should be legibly typed. It should contain a total of 15 practical skill based very short answer type questions. A student would be required to answer any 10 questions.
- A writer may be allowed to such students as per CBSE examination rules.
- All questions included in the question papers should be related to the listed practicals. Every question should require about two minutes to be answered.
- These students are also required to maintain a practical file. A student is expected to record at least five of the listed experiments as per the specific instructions for each subject. These practicals should be duly checked and signed by the internal examiner.
- The format of writing any experiment in the practical file should include aim, apparatus required, simple theory, procedure, related practical skills, precautions etc.
- Questions may be generated jointly by the external/internal examiners and used for assessment.
- The viva questions may include questions based on basic theory/principle/concept, apparatus/materials/ chemicals required, procedure, precautions, sources of error etc.

A. Items for Identification/Familiarity of the apparatus for assessment in practical (All experiments)

Beaker, glass rod, tripod stand, wire gauze, Bunsen burner, Whatman filter paper, gas jar, capillary tube, pestle and mortar, test tubes, tongs, test tube holder, test tube stand, burette, pipette, conical flask, standard flask, clamp stand, funnel, filter paper

Hands-on Assessment

- Identification/familiarity with the apparatus
- Odour detection in qualitative analysis

B. List of Practicals

The experiments have been divided into two sections: Section A and Section B. The experiments mentioned in Section B are mandatory.

SECTION- A

A Surface Chemistry

- (1) Preparation of one lyophilic and one lyophobic sol
Lyophilic sol - starch, egg albumin and gum
- (2) Preparation of one lyophobic sol
Lyophobic sol – Ferric hydroxide

Chromatography
(1) Separation of pigments from extracts of leaves and flowers by paper chromatography and determination of R_f values (distance values may be provided).

C Tests for the functional groups present in organic compounds:

- (1) Alcoholic and Carboxylic groups.

(2) Aldehydic and Ketonic

**D Characteristic tests of carbohydrates and proteins in the given foodstuffs. E
Preparation of Inorganic Compounds- Potash Alum**

SECTION-B (Mandatory)

F Quantitative analysis

- (1) (a) Preparation of the standard solution of Oxalic acid of a given volume
(b) Determination of molarity of KMnO_4 solution by titrating it against a standard solution of Oxalic acid.
- (2) The above exercise [F 1 (a) and (b)] to be conducted using Ferrous ammonium sulphate (Mohr's salt)

G Qualitative analysis:

- (1) Determination of one cation and one anion in a given salt.

Cation – NH_4^+

Anions – CO_3^{2-} , S^{2-} , SO_3^{2-} , Cl^- , CH_3COO^-

(Note: Insoluble salts excluded)

Note: The above practicals may be carried out in an experiential manner rather than recording observations.

Prescribed Books:

1. Chemistry Part -I, Class-XII, Published by NCERT.
2. Chemistry Part -II, Class-XII, Published by NCERT.

CHEMISTRY (Code No. 043) QUESTION PAPER DESIGN CLASSES –XI and XII (2023-24)

S	Domains	Total Marks	%
1	Remembering and Understanding: Exhibit memory of previously learned material by recalling facts, terms, basic concepts and answers. Demonstrate understanding of facts and ideas by organizing, comparing, translating, interpreting, giving descriptions and stating main ideas.	28	40
2	Applying: Solve problems to new situations by applying acquired knowledge, facts, techniques and rules in a different way.	21	30
3	Analysing, Evaluating and Creating: Examine and break information into parts by identifying motives or causes. Make inferences and find evidence to support generalizations. Present and defend opinions by making judgments about information, validity of ideas or quality of work based on a set of criteria. Compile information together in a different way by combining elements in a new pattern or proposing alternative solutions.	21	30

1. No chapter wise weightage. Care to be taken to cover all the chapters.
2. Suitable *internal variations may be made for generating various templates. Choice(s):*

- There will be no overall choice in the question paper.
- However, 33% internal choices will be given in all the sections.

SAMPLE PAPER (2023 -24)

CHEMISTRY THEORY (043)

Max. Marks:70

Time: 3 hours

General Instructions:

Read the following instructions carefully.

- There are **33** questions in this question paper with internal choice.
 - SECTION A consists of 16 multiple-choice questions carrying 1 mark each.
 - SECTION B consists of 5 short answer questions carrying 2 marks each.
 - SECTION C consists of 7 short answer questions carrying 3 marks each.
 - SECTION D consists of 2 case-based questions carrying 4 marks each.
 - SECTION E consists of 3 long answer questions carrying 5 marks each.
 - All questions are compulsory.
 - Use of log tables and calculators is not allowed.
-

SECTION A

The following questions are multiple-choice questions with one correct answer. Each question carries 1 mark. There is no internal choice in this section.

- Which of the following solutions will have the highest conductivity at 298 K?
 - 0.01 M HCl solution
 - 0.1 M HCl solution
 - 0.01 M CH₃COOH solution
 - 0.1 M CH₃COOH solution

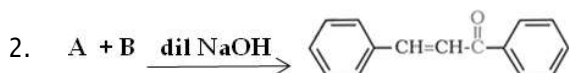

Identify A and B:

- A = 1-phenylethanal, B = acetophenone
 - A = Benzophenone, B = formaldehyde
 - A = Benzaldehyde, B = Acetophenone
 - A = Benzophenone, B = Acetophenone
- The vitamins which can be stored in our body are:
 - Vitamin A, B, D and E
 - Vitamin A, C, D and K
 - Vitamin A, B, C and D
 - Vitamin A, D, E and K
 - What is IUPAC name of the ketone A, which undergoes iodoform reaction to give CH₃CH=C(CH₃)COONa and yellow precipitate of CHI₃?
 - 3-Methylpent-3-en-2-one
 - 3-Methylbut-2-en- one
 - 2, 3-Dimethylethanone
 - 3-Methylpent-4-one
 - Which of the following is not correct?
 - In haloarenes, the electron pairs on halogen atom are in conjugation with π-electrons of the ring.
 - The carbon-magnesium bond is covalent and non-polar in nature.
 - During S_N1 reaction, the carbocation formed in the slow step being sp² hybridised is planar.
 - Out of CH₂=CH-Cl and C₆H₅CH₂Cl, C₆H₅CH₂Cl is more reactive towards S_N1 reaction

6. Match the properties with the elements of 3d series:

- | | |
|--|--------|
| (i) lowest enthalpy of atomisation | (p) Sc |
| (ii) shows maximum number of oxidation states | (q) Mn |
| (iii) transition metal that does not form coloured compounds | (r) Zn |
| | (s) Ti |

- | | |
|----------------------------------|----------------------------------|
| (a) (i) (r), (ii) (q), (iii) (p) | (b) (i) (r), (ii) (s), (iii) (p) |
| (c) (i) (p), (ii) (q), (iii) (r) | (d) (i) (s), (ii) (r), (iii) (p) |

7. Which of the following statement is true?

- (a) molecularity of reaction can be zero or a fraction.
- (b) molecularity has no meaning for complex reactions.
- (c) molecularity of a reaction is an experimental quantity
- (d) reactions with the molecularity three are very rare but are fast.

8. In which of the following solvents, the $C_4H_8NH_3^+X^-$ is soluble;

- (a) ether
- (b) acetone
- (c) water
- (d) bromine water

9. Which of the following observation is shown by 2-phenyl ethanol with Lucas Reagent?

- (a) Turbidity will be observed within five minutes
- (b) No turbidity will be observed
- (c) Turbidity will be observed immediately
- (d) Turbidity will be observed at room temperature but will disappear after five minutes.

10. If the initial concentration of substance A is 1.5 M and after 120 seconds the concentration of substance A is 0.75 M, the rate constant for the reaction if it follows zero - order kinetics is:

- (a) $0.00625 \text{ molL}^{-1}\text{s}^{-1}$
- (b) 0.00625 s^{-1}
- (c) $0.00578 \text{ molL}^{-1}\text{s}^{-1}$
- (d) 0.00578 s^{-1}

11. Anisole undergoes bromination with bromine in ethanoic acid even in the absence of iron (III) bromide catalyst

- (a) Due to the activation of benzene ring by the methoxy group.
- (b) Due to the de-activation of benzene ring by the methoxy group.
- (c) Due to the increase in electron density at ortho and para positions
- (d) Due to the formation of stable carbocation.

12. The trend of which property is represented by the following graph?

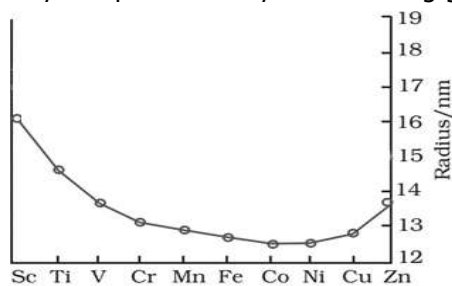

- | | |
|-----------------------------|-------------------|
| (a) ionization enthalpy | (b) atomic radii |
| (c) enthalpy of atomization | (d) melting point |

For Visually Challenged Learners

12. Which of the following is not considered a transition element?

- (a) Scandium (b) Silver (c) Vanadium (d) Zinc

13. Given below are two statements labelled as Assertion (A) and Reason (R)

Assertion (A): Alcohols react both as nucleophiles and electrophiles.

Reason (R): The bond between C–O is broken when alcohols react as nucleophiles.

Select the most appropriate answer from the options given below:

- (a) Both A and R are true and R is the correct explanation of A
(b) Both A and R are true but R is not the correct explanation of A.
(c) A is true but R is false.
(d) A is false but R is true.

14. Given below are two statements labelled as Assertion (A) and Reason (R)

Assertion (A): Strong oxidising agents oxidise toluene and its derivatives to benzoic acids.

Reason (R): It is possible to stop the oxidation of toluene at the aldehyde stage with suitable reagents.

Select the most appropriate answer from the options given below:

- (a) Both A and R are true and R is the correct explanation of A
(b) Both A and R are true but R is not the correct explanation of A.
(c) A is true but R is false.
(d) A is false but R is true.

15. Given below are two statements labelled as Assertion (A) and Reason (R)

Assertion (A): Enzymes are very specific for a particular reaction and for a particular substrate.

Reason (R): Enzymes are biocatalysts.

Select the most appropriate answer from the options given below:

- (a) Both A and R are true and R is the correct explanation of A
(b) Both A and R are true but R is not the correct explanation of A.
(c) A is true but R is false.
(d) A is false but R is true.

16. Given below are two statements labelled as Assertion (A) and Reason (R)

Assertion (A): During electrolysis of aqueous copper sulphate solution using copper electrodes hydrogen gas is released at the cathode.

Reason (R): The electrode potential of $\text{Cu}^{2+} / \text{Cu}$ is greater than that of H^+ / H_2

Select the most appropriate answer from the options given below:

- (a) Both A and R are true and R is the correct explanation of A
(b) Both A and R are true but R is not the correct explanation of A.
(c) A is true but R is false.
(d) A is false but R is true.

SECTION B

This section contains 5 questions with internal choice in one question. The following questions are very short answer type and carry 2 marks each.

17. a. Radioactive decay follows first – order kinetics. The initial amount of two radioactive elements X and Y is 1 gm each. What will be the ratio of X and Y after two days if their half-lives are 12 hours and 16 hours respectively?
b. The hypothetical reaction $P + Q \longrightarrow R$ is half order w.r.t 'P' and zero order w.r.t 'Q'. What is the unit of rate constant for this reaction?
18. A 5% solution of $\text{Na}_2\text{SO}_4 \cdot 10\text{H}_2\text{O}$ (MW = 322) is isotonic with 2% solution of non- electrolytic, non volatile substance X. Find out the molecular weight of X.
19. (a) Arrange the isomeric dichlorobenzene in the increasing order of their boiling point and melting points.
(b) Explain why the electrophilic substitution reactions in haloarenes occur slowly and require more drastic conditions as compared to those in benzene.
20. (a) Out of p-tolualdehyde and p-nitrobenzaldehyde, which one is more reactive towards nucleophilic addition reactions, why?
(b) Write the structure of the product formed when acetone reacts with 2,4 DNP reagent.

OR

Convert the following:

- (a) Benzene to m-nitrobenzaldehyde
(b) Bromobenzene to benzoic acid
21. (a) DNA fingerprinting is used to determine paternity of an individual. Which property of DNA helps in the procedure?
(b) What structural change will occur when a native protein is subjected to change in pH?

SECTION C

This section contains 7 questions with internal choice in one question. The following questions are short answer type and carry 3 marks each.

22. (a) Write the formula for the following coordination compound
Bis(ethane-1,2-diamine) dihydroxidochromium(III) chloride
(b) Does ionization isomer for the following compound exist? Justify your answer.
 $\text{Hg}[\text{Co}(\text{SCN})_4]$
(c) Is the central metal atom in coordination complexes a Lewis acid or a Lewis base? Explain.
23. (a) Can we construct an electrochemical cell with two half-cells composed of ZnSO_4 solution and zinc electrodes? Explain your answer.
(b) Calculate the λ_m^0 for Cl^- ion from the data given below:
 $\Lambda_m^0 \text{MgCl}_2 = 258.6 \text{ Scm}^2\text{mol}^{-1}$ and $\lambda_m^0 \text{Mg}^{2+} = 106 \text{ Scm}^2\text{mol}^{-1}$
(c) The cell constant of a conductivity cell is 0.146 cm^{-1} . What is the conductivity of 0.01 M solution of an electrolyte at 298 K, if the resistance of the cell is 1000 ohm?

24. Write the name of the reaction, structure and IUPAC name of the product formed when (**any 2**):
- phenol reacts with CHCl_3 in the presence of NaOH followed by hydrolysis.
 - $\text{CH}_3\text{CH}_2\text{CH}(\text{CH}_3)\text{CH}(\text{CH}_3)\text{ONa}$ reacts with $\text{C}_2\text{H}_5\text{Br}$
 - $\text{CH}_3\text{CH}_2\text{CN}$ reacts with stannous chloride in the presence of hydrochloric acid followed by hydrolysis
25. You are given four organic compounds "A", "B", "C" and "D". The compounds "A", "B" and "C" form an orange-red precipitate with 2,4 DNP reagent. Compounds "A" and "B" reduce Tollen's reagent while compounds "C" and "D" do not. Both "B" and "C" give a yellow precipitate when heated with iodine in the presence of NaOH . Compound "D" gives brisk effervescence with sodium bicarbonate solution. Identify "A", "B", "C" and "D" given the number of carbon atoms in three of these carbon compounds is three while one has two carbon atoms. Give an explanation for your answer.
26. When sucrose is hydrolysed the optical rotation values are measured using a polarimeter and are given in the following table:

S.No.	Time (hours)	Specific Rotation
1	0	+ 66.5°
2	∞	-39.9°

- Account for the two specific rotation values.
 - What is the specific name given to sucrose based on the above observation?
 - One of the products formed during the hydrolysis of sucrose is a glucose, that reacts with hydroxylamine to give compound A. Identify compound A.
27. An organic compound A with the molecular formula $(+)\text{C}_4\text{H}_9\text{Br}$ undergoes hydrolysis to form $(\pm)\text{C}_4\text{H}_9\text{OH}$. Give the structure of A and write the mechanism of the reaction.
28. The rate constants of a reaction at 200K and 500K are 0.02s^{-1} and 0.20s^{-1} respectively. Calculate the value of E_a (Given $2.303R = 19.15 \text{ JK}^{-1}\text{mol}^{-1}$)

SECTION D

The following questions are case-based questions. Each question has an internal choice and carries 4 (1+1+2) marks each. Read the passage carefully and answer the questions that follow.

29. **Crystal field splitting by various ligands**

Metal complexes show different colours due to d-d transitions. The complex absorbs light of specific wavelength to promote the electron from t_{2g} to e_g level. The colour of the complex is due to the transmitted light, which is complementary of the colour absorbed.

The wave number of light absorbed by different complexes of Cr ion are given below:

Complex	Wavenumber of light absorbed (cm^{-1})	Energy of light absorbed (kJ/mol)
$[\text{CrA}_6]^{3-}$	13640	163
$[\text{CrB}_6]^{3+}$	17830	213
$[\text{CrC}_6]^{3+}$	21680	259
$[\text{CrD}_6]^{3-}$	26280	314

Answer the following questions:

- (a) Out of the ligands "A", "B", "C" and "D", which ligand causes maximum crystal field splitting? Why?

OR

Which of the two, "A" or "D" will be a weak field ligand? Why?

- (b) Which of the complexes will be violet in colour? $[\text{CrA}_6]^{3-}$ or $[\text{CrB}_6]^{3+}$ and why? (Given: If 560 – 570 nm of light is absorbed, the colour of the complex observed is violet.)
- (c) If the ligands attached to Cr^{3+} ion in the complexes given in the table above are water, cyanide ion, chloride ion, and ammonia (not in this order)

Identify the ligand, write the formula and IUPAC name of the following:

- (i) $[\text{CrA}_6]^{3-}$ (ii) $[\text{CrC}_6]^{3+}$

30. The lead–acid battery represents the oldest rechargeable battery technology. Lead acid batteries can be found in a wide variety of applications including small–scale power storage such as UPS systems, ignition power sources for automobiles, along with large, grid–scale power systems. The spongy lead act as the anode and lead dioxide as the cathode. Aqueous sulphuric acid is used as an electrolyte. The half–reactions during discharging of lead storage cells are:

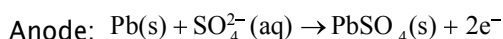

There is no safe way of disposal and these batteries end – up in landfills. Lead and sulphuric acid are extremely hazardous and pollute soil, water as well as air. Irrespective of the environmental challenges it poses, lead–acid batteries have remained an important source of energy.

Designing green and sustainable battery systems as alternatives to conventional means remains relevant. Fuel cells are seen as the future source of energy. Hydrogen is considered a green fuel. Problem with fuel cells at present is the storage of hydrogen. Currently, ammonia and methanol are being used as a source of hydrogen for fuel cell. These are obtained industrially, so add to the environmental issues.

If the problem of storage of hydrogen is overcome, is it still a "green fuel?" Despite being the most abundant element in the Universe, hydrogen does not exist on its own so needs to be extracted from the water using electrolysis or separated from carbon fossil fuels. Both of these processes require a significant amount of energy which is currently more than that gained from the hydrogen itself. In addition, this extraction typically requires the use of fossil fuels. More research is being conducted in this field to solve these problems. Despite the problem of no good means to extract Hydrogen, it is a uniquely abundant and renewable source of energy, perfect for our future zero–carbon needs.

Answer the following questions:

- (a) How many coulombs have been transferred from anode to cathode in order to consume one mole of sulphuric acid during the discharging of lead storage cell?
- (b) How much work can be extracted by using lead storage cell if each cell delivers about 2.0 V of voltage? ($1\text{ F} = 96500\text{ C}$)
- (c) Do you agree with the statement – "Hydrogen is a green fuel." Give your comments for and against this statement and justify your views.

OR

Imagine you are a member of an agency funding scientific research. Which of the following projects will you fund and why?

- (i) safe recycling of lead batteries
- (ii) extraction of hydrogen

SECTION E

The following questions are long answer type and carry 5 marks each. All questions have an internal choice.

31. Attempt **any five** of the following:

- (a) Which of the following ions will have a magnetic moment value of 1.73 BM.

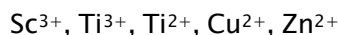

- (b) In order to protect iron from corrosion, which one will you prefer as a sacrificial electrode, Ni or Zn? Why? (Given standard electrode potentials of Ni, Fe and Zn are -0.25 V , -0.44 V and -0.76 V respectively.)
- (c) The second ionization enthalpies of chromium and manganese are 1592 kJ/mol and 1509 kJ/mol respectively. Explain the lower value of Mn.
- (d) Give two similarities in the properties of Sc and Zn.
- (e) What is actinoid contraction? What causes actinoid contraction?
- (f) What is the oxidation state of chromium in chromate ion and dichromate ion?
- (g) Write the ionic equation for reaction of KI with acidified KMnO_4 .
32. (a) What is the effect of temperature on the solubility of glucose in water?
- (b) Ibrahim collected a 10mL each of fresh water and ocean water. He observed that one sample labeled "P" froze at $0\text{ }^\circ\text{C}$ while the other "Q" at $-1.3\text{ }^\circ\text{C}$. Ibrahim forgot which of the two, "P" or "Q" was ocean water. Help him identify which container contains ocean water, giving rationalization for your answer.
- (c) Calculate Van't Hoff factor for an aqueous solution of $\text{K}_3[\text{Fe}(\text{CN})_6]$ if the degree of dissociation (α) is 0.852. What will be boiling point of this solution if its concentration is 1 molal? ($K_b=0.52\text{ K kg/mol}$)

OR

- (a) What type of deviation from Raoult's Law is expected when phenol and aniline are mixed with each other? What change in the net volume of the mixture is expected? Graphically represent the deviation.
- (b) The vapour pressure of pure water at a certain temperature is 23.80 mm Hg . If 1 mole of a non-volatile non-electrolytic solute is dissolved in 100g water, Calculate the resultant vapour pressure of the solution.
33. An organic compound with molecular formula $\text{C}_7\text{H}_7\text{NO}_2$ exists in three isomeric forms, the isomer 'A' has the highest melting point of the three. 'A' on reduction gives compound 'B' with molecular formula $\text{C}_7\text{H}_9\text{N}$. 'B' on treatment with NaNO_2/HCl at $0-5\text{ }^\circ\text{C}$ to form compound 'C'. On treating C with H_3PO_2 , it gets converted to D with formula C_7H_8 , which on further reaction with CrO_2Cl_2 followed by hydrolysis forms 'E' $\text{C}_7\text{H}_6\text{O}$. Write the structure of compounds A to E. Write the chemical equations involved.

OR

(a) Account for the following:

(i) N-ethylbenzenesulphonyl amide is soluble in alkali .

(ii) Reduction of nitrobenzene using Fe and HCl is preferred over Sn and HCl.

(b) Arrange the following in:

(i) decreasing order of pK_b values

$C_6H_5NH_2$, $C_6H_5NHCH_3$, $C_6H_5CH_2NH_2$, CH_3NH_2 , NH_3

(ii) increasing order of solubility in water

C_2H_5Cl , $C_2H_5NH_2$, C_2H_5OH

(iii) decreasing boiling point

CH_3COOH , C_2H_5OH , CH_3NH_2 , CH_3OCH_3

SAMPLE PAPER (2023 -24)
CHEMISTRY THEORY (043)
MARKING SCHEME

SECTION A

1. (b) 0.1 M HCl solution, conductivity is higher for strong electrolyte, conductivity decreases with dilution
2. (c) A= Benzaldehyde , B= Acetophenone. This is an example of crossed Aldol condensation.
3. (d) Vitamin A,D, E and K These are fat soluble vitamins
4. (a) 3-Methylpent-3-en-2-one
5. (b) The carbon-magnesium bond is covalent and non-polar in nature .
6. (a) (i) (r) , (ii) (q), (iii) (p)
Zinc has no unpaired electrons in 3d or 4s orbitals, so enthalpy of atomization is low
Mn = 3d⁵4s² shows +2,+3,+4,+5,+6 and+7 oxidation state , maximum number in 3d series
7. (b) molecularity has no meaning for complex reactions.
8. (c) water
9. (b) no turbidity will be observed, given compound is a primary alcohol
10. (a) 0.00625 molL⁻¹s⁻¹ for zero order $k = [R_0] - [R] / t = 1.5 - 0.75 / 120$
11. (a) Due to the activation of benzene ring by the methoxy group.
12. (b) atomic radii

for visually challenged learners

12. (d) Zinc
13. (c) A is true but R is false
14. (b) Both A and R are true but R is not the correct explanation of A
15. (b) Both A and R are true and R is not the correct explanation of A.
16. (d) A is false but R is true.

Cu will deposit at cathode

SECTION B

17. (a) for first order reaction

half life of X = 12 hours

2 days = 48 hours means 4 half lives , amount of X left = 1/16 of initial value

half life of Y = 16 hours (1/2)

2 days = 48 hours means 3 half lives, amount left = 1/8 of initial value

Ratio of X:Y = 1:2 (1/2)

- (b) $\text{mol}^{1/2}\text{L}^{-1/2}\text{s}^{-1}$ as Rate = $k [P]^{1/2}$ (1)

18. $\pi_1 = \pi_2$ (1/2)

$iC_1RT = C_2RT$ (1/2)

$$\frac{3 \times 5}{322} = \frac{2}{M} \quad (1/2)$$

$$M = \frac{2 \times 322}{3 \times 5} \quad (1/2)$$

$$M = 42.9 \text{ g}$$

19. (a) m-dichlorobenzene < o-dichlorobenzene < p-dichlorobenzene (1/2)
 symmetrical structure and close packing in para isomer

ortho has a stronger dipole dipole interaction as compared to meta (1/2)

(b) the halogen atom because of its -I effect has some tendency to withdraw electrons from the benzene ring. As a result, the ring gets somewhat deactivated as compared to benzene and hence the electrophilic substitution reactions in haloarenes occur slowly and require more drastic conditions as compared to those in benzene. (1)

20. (a) p-nitrobenzaldehyde is more reactive towards the nucleophilic addition reaction than p-tolualdehyde as Nitro group is electron withdrawing in nature. Presence of nitro group decrease electron density, hence facilitates the attack of nucleophile. Presence of -CH₃ leads to +I effect as -CH₃ is electron releasing group. (1)

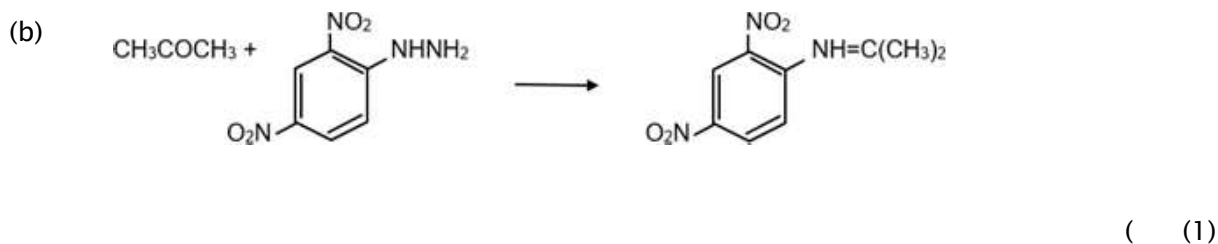

OR

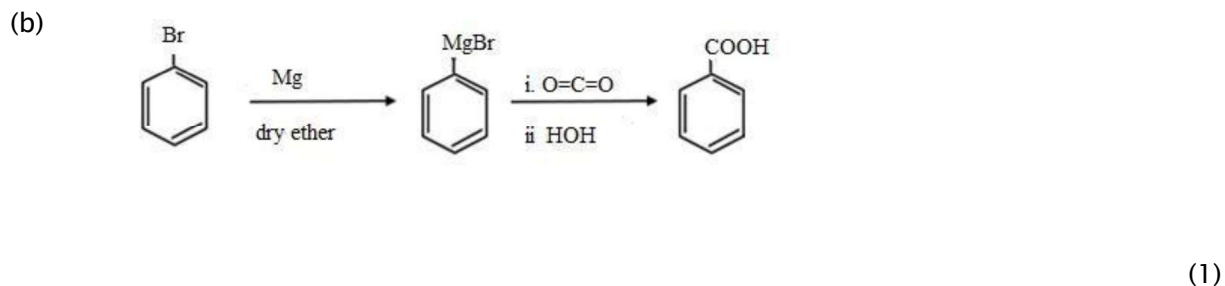
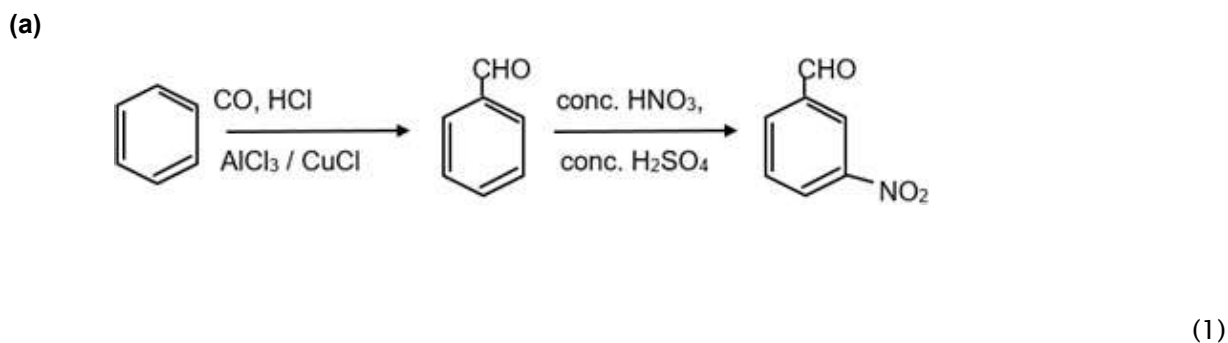

21. (a) Replication

A sequence of bases on DNA is unique for a person and is the genetic material transferred to the individual from the parent which helps in the determination of paternity. (1)

(b) During denaturation secondary and tertiary structures are destroyed but the primary structure remains intact. (1)

SECTION C

22. (a) $[\text{Cr}(\text{en})_2(\text{OH})_2]\text{Cl}$ or $[\text{Cr}(\text{H}_2\text{NCH}_2\text{CH}_2\text{NH}_2)_2(\text{OH})_2]\text{Cl}$ (1)

(b) No, ionization isomers are possible by exchange of ligand with counter ion only and not by exchange of central metal ion. (1)

(c) The central atom is electron pair acceptor so it is a Lewis acid. (1)

23. (a) Yes, if the concentration of ZnSO_4 in the two half cell is different, the electrode potential will be different making the cell possible. (1)

(b) $\Lambda^0_m(\text{MgCl}_2) = \lambda^0_m(\text{Mg}^{2+}) + 2\lambda^0_m(\text{Cl}^-)$

$$258.6 = 106 + 2\lambda^0_m(\text{Cl}^-)$$

$$\lambda^0_m(\text{Cl}^-) = 76.3 \text{ Scm}^2\text{mol}^{-1} \quad (1)$$

(c) cell constant $G^* = k \times R$

$$k = G^*/R = 0.146 / 1000 = 1.46 \times 10^{-4} \text{ Scm}^{-1}. \quad (1)$$

24. (a) Reimer Tiemann, (1/2)

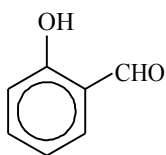

2-Hydroxybenzaldehyde

(1/2+1/2)

(b) Williamson synthesis, $\text{CH}_3\text{CH}_2\text{CH}(\text{CH}_3)\text{CH}(\text{CH}_3)\text{O C}_2\text{H}_5$

2-Ethoxy-3-methylpentane

(1/2+1/2+1/2)

(c) Stephen reaction, $\text{CH}_3\text{CH}_2\text{CHO}$, Propanal

(1/2+1/2 +1/2)

25. A, B and C contain carbonyl group as they give positive 2,4 DNP test

A and B are aldehydes as aldehydes reduce Tollen's reagent

C is a ketone, as it contains carbonyl group but does not give positive Tollen's test (1/2)

C is a methyl ketone as it gives positive iodoform test

B is an aldehyde that gives positive iodoform test (1/2)

D is a carboxylic acid

Since the number of carbons in the compounds A,B,C and D is three or two

B is CH_3CHO as this is only aldehyde which gives a positive iodoform test (1/2)

The remaining compounds A, C and D have three carbons

A is $\text{CH}_3\text{CH}_2\text{CHO}$, C is CH_3COCH_3 and D is $\text{CH}_3\text{CH}_2\text{COOH}$ (1/2 each)

26. (a) The reactant Sucrose is dextrorotatory. On hydrolysis it give glucose dextrorotatory and fructose which is levorotatory. The specific rotation of fructose is higher than glucose

Sucrose is dextrorotatory but after hydrolysis gives dextrorotatory glucose and levorotatory fructose. Since the levorotation of fructose (-92.4°) is more than dextrorotation of glucose ($+52.5^\circ$), the mixture is levorotatory. (1)

(b) Invert sugar, The hydrolysis of sucrose brings about a change in the sign of rotation, from dextro (+) to laevo (-) and the product is named as invert sugar. (1)

(c) Glucose (1)

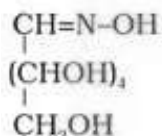

Mechanism:

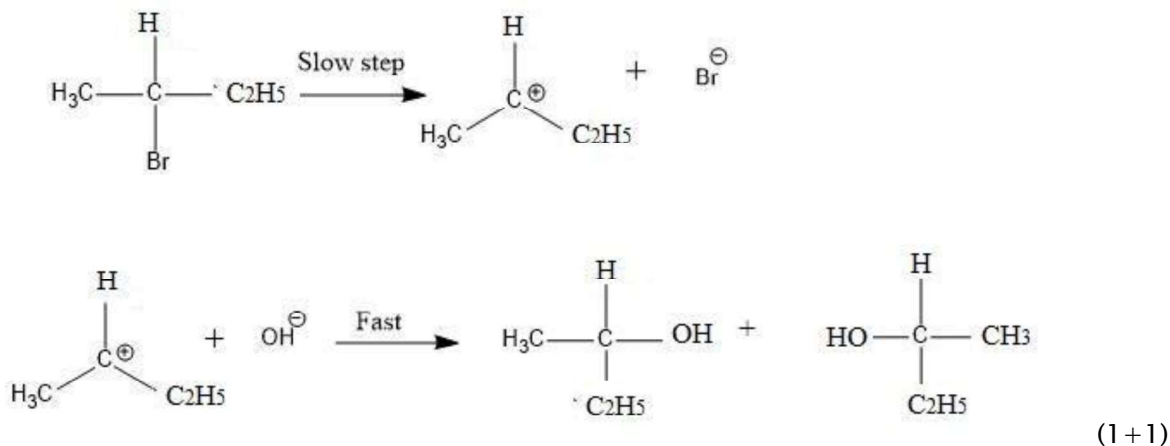

28.

$$\log\left(\frac{k_2}{k_1}\right) = \frac{E_a}{2.303R} \left[\frac{1}{T_1} - \frac{1}{T_2} \right]$$

$$\log\frac{0.20}{0.05} = \frac{E_a}{2.303R} \left[\frac{1}{200} - \frac{1}{500} \right]$$

$$\log 10 = \frac{E_a}{19.15} \left(\frac{300}{200 \times 500} \right)$$

$$E_a = \frac{19.15 \times 200 \times 500}{300}$$

$$E_a = 6383 \text{ J / mol}$$

(1+1+1)

SECTION D

29. (a) D. Energy is directly proportional to the wave number. Maximum energy of light is required for an electron to jump from t_{2g} to e_g in case of $[\text{CrD}_6]^{3-}$ (1/2+1/2)

OR

(a) A, The splitting caused in least in this case as the energy required for electron to jump from t_{2g} to e_g , is minimum. (1/2 +1/2)

(b) $[\text{CrB}_6]^{3+}$, wavelength of light absorbed is $1/17830 = 560\text{nm}$ for the complex while $1/13640 = 733\text{nm}$ for $[\text{CrA}_6]^{3-}$ complex. (1/2+1/2)

(c) (i) $[\text{CrCl}_6]^{3-}$, Hexachloridochromate(III) ion (1 each)

(ii) $[\text{Cr}(\text{NH}_3)_6]^{3+}$, Hexaamminechromium(III) ion

A = Cl^- , B = H_2O , C = NH_3 , D = CN^-

30. (a) 2mol e^- (or 2F) have been transferred from anode to cathode to consume 2 mol of H_2SO_4

therefore, one mole H_2SO_4 requires one faraday of electricity or 96500 coulombs. (1)

(b) $w_{\text{max}} = -nFE^\circ = -2 \times 96500 \times 2.0 = 386000 \text{ J}$ of work can be extracted using lead storage cell when the cell is in use. (1)

(c) **Both yes and no should be accepted as correct answers depending upon what explanation is provided.**

Yes, Hydrogen is a fuel that on combustion gives water as a byproduct. There are no carbon emissions and no pollutions caused.

However, at present the means to obtain hydrogen are electrolysis of water which use electricity obtained from fossil fuels and increase carbon emissions.

In spite of the problems faced today in the extraction of hydrogen, we cannot disagree on the fact that hydrogen is a clean source of energy. Further research can help in finding solutions and greener ways like using solar energy for extraction of hydrogen. (2)

No. It is true that Hydrogen is a fuel that on combustion gives water as a byproduct. There are no carbon emissions and no pollutions caused.

However, at present the means to obtain hydrogen are electrolysis of water which use electricity obtained from fossil fuels and increase carbon emissions.

Hydrogen is no doubt a green fuel, but the process of extraction is not green as of today. At present, looking at the process of extraction, hydrogen is not a green fuel. (2)

OR

Both answers will be treated as correct

(i) Lead batteries are currently the most important and widely used batteries. These are rechargeable. The problem is waste management which needs research and awareness. Currently, these are being thrown into landfills and there is no safe method of disposal or recycling. Research into safer method of disposal will reduce the pollution and health hazards caused to a great extent.

(1 mark for importance, 1 for need for the research)

(ii) Fuel cell is a clean source of energy. Hydrogen undergoes combustion to produce water. The need of the hour is green fuel and hydrogen is a clean fuel. The current problem is obtaining hydrogen. Research that goes into this area will help solve the problem of pollution and will be a sustainable solution.

(1 mark for importance, 1 for need for the research)

SECTION E

31. (a) Both Ti^{3+} and Cu^{2+} have 1 unpaired electron, so the magnetic moment for both will be 1.73 BM
- (b) Zn, it has a more negative electrode potential so will corrode itself in place of iron.
- (c) Mn^{2+} has $3d^5 4s^1$ configuration and configuration of Cr^{3+} is $3d^3$, therefore, ionisation enthalpy of Mn^{2+} is lower than Cr^{3+} .
- (d) Sc and Zn both form colourless compound and are diamagnetic.
- (e) The decrease in the atomic and ionic radii with increase in atomic number of actinoids due to poor shielding effect of 5f electron.
- (f) In both chromate and dichromate ion the oxidation state of Cr is +6
- (g) $10\text{I}^- + 2\text{MnO}_4^- + 16\text{H}^+ \rightarrow 2\text{Mn}^{2+} + 8\text{H}_2\text{O} + 5\text{I}_2$ (1 each, any 5)

32. (a) Addition of glucose to water is an endothermic reaction. According to Le Chatelier's principle, on increase in temperature, solubility will increase. (1)
- (b) Q is ocean water, due to the presence of salts it freezes at lower temperature (depression in freezing point) (1)
- (c) $K_3 [Fe(CN)_6]$ gives 4 ions in aqueous solution (1/2)
- $$i = 1 + (n-1)\alpha \quad (1/2)$$
- $$i = 1 + (4-1) \times 0.0.852$$
- $$i = 3.556 \quad (1/2)$$
- $$\Delta T_b = i K_b m = 3.556 \times 0.52 \times 1 = 1.85 \quad (1)$$
- $$T_b = 101.85^\circ C \quad (1/2)$$

OR

- (a) Negative Deviation is expected when phenol and aniline are mixed with each other. The net volume of the mixture will decrease, $\Delta V < 0$ due to stronger intermolecular interactions. (1)

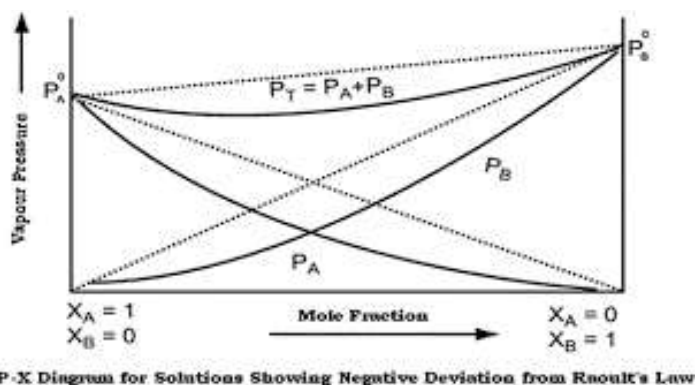

- (1)
- (b) Relative lowering of vapour pressure = $(P^\circ - P) / P^\circ = x_2$ (1/2)
- $$x_2 = n_2 / n_1$$
- $$n_2 = 0.1$$
- $$n_1 = 100/18$$
- $$x_2 = 0.1 / 5.55 + 0.1 = 0.1 / 5.65 = 0.018 \quad (1/2)$$
- $$P^\circ = 23.8 \text{ mm Hg}$$
- $$\text{Relative lowering of vapour pressure} = (23.80 - P) / 23.80 = 0.018 \quad (1/2)$$
- $$23.80 - P = 0.428 \quad (1/2)$$
- $$P = 23.80 - 0.428 = 23.37 \text{ mm Hg} \quad (1)$$

33. Compound "A" is p-methylnitrobenzene Compound "B" is p-methylbenzenamine
 Compound C is p-methylbenzenediazoiiumchloride Compound D - Toluene
 Compound E - Benzaldehyde
 The chemical reactions involved are

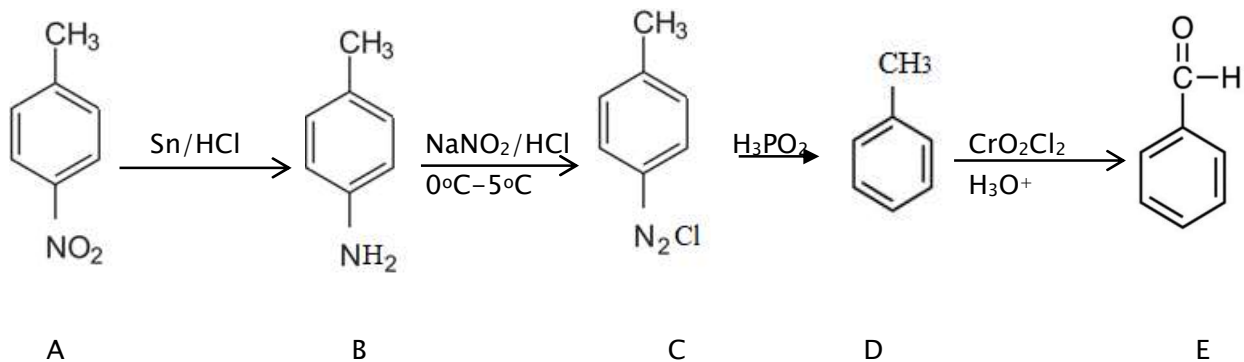

(1 mark for correct identification of A, 1 each for identification and reaction of formation of B,C,D and E from A)

OR

(a) (i) The hydrogen attached to N-Ethylbenzene sulphonamide is acidic in nature. This is due to the presence of strong electron withdrawing sulphonyl group. Hence, it is soluble in alkali. (1)

(ii) Reduction with iron scrap and hydrochloric acid is preferred because FeCl₂ formed gets hydrolysed to release hydrochloric acid during the reaction. Thus, only a small amount of hydrochloric acid is required to initiate the reaction. (1)

(b) (i) C₆H₅NH₂ > C₆H₅NHCH₃ > NH₃ > C₆H₅CH₂NH₂ > CH₃NH₂ (1)

(ii) C₂H₅Cl < C₂H₅NH₂ < C₂H₅OH (1)

(iii) CH₃COOH > C₂H₅OH > CH₃NH₂ > CH₃OCH₃ (1)

Chemistry (Class XII)

(I) Read the passage given below and answer the following questions:

In spite of the predictions of stable noble gas compounds since at least 1902, unsuccessful attempts at their synthesis gave rise to the widely held opinion that noble gases are not only noble but also inert. It was not until 1962 that this dogma was shattered when Bartlett in Canada published the first stable noble gas compound XePtF_6 . This discovery triggered a worldwide frenzy in this area, and within a short time span many new xenon, radon, and krypton compounds were prepared and characterized. The recent discoveries show the ability of xenon to act as a ligand. The discovery by Seppelt's group that more than one xenon atom can attach itself to a metal center which in the case of gold leads to surprisingly stable Au-Xe bonds. The bonding in $[\text{AuXe}_4]^{2+}$ involves 4 Xe ligands attached by relatively strong bonds to a single Au(II) center in a square planar arrangement with a Xe-Au bond length of about 274 pm. This discovery provides not only the first example of multiple xenon ligands but also represents the first strong metal - xenon bond.

(Source: Christie, K. O. (2001). A renaissance in noble gas chemistry. *Angewandte Chemie International Edition*, 40(8), 1419-1421.)

1. In the complex ion $[\text{AuXe}_4]^{2+}$, Xe acts as :
 - a. central atom
 - b. ligand
 - c. chelating agent
 - d. electrophile
2. Hybridisation shown by Au in $[\text{AuXe}_4]^{2+}$ is :
 - a. sp^3
 - b. sp^3d
 - c. sp^3d^2
 - d. sp^2
3. Compounds of noble gases except _____ are known.
 - a. Krypton
 - b. Radon
 - c. Helium
 - d. Xenon
4. Xe is a _____ ligand
 - a. ambidentate
 - b. bidentate
 - c. unidentate
 - d. hexadentate

ANSWERS : 1a, 2 b 3 c 4 c

(II) Read the passage given below and answer the following questions:

Boiling point or freezing point of liquid solution would be affected by the dissolved solids in the liquid phase. A soluble solid in solution has the effect of raising its boiling point and depressing its freezing point. The addition of non-volatile substances to a solvent decreases the vapor pressure and the added solute particles affect the formation of pure solvent crystals. According to many researches the decrease in freezing point directly correlated to the concentration of solutes dissolved in the solvent. This phenomenon is expressed as freezing point depression and it is useful for several applications such as freeze concentration of liquid food and to find the molar mass of an unknown solute in the solution. Freeze concentration is a high quality liquid food concentration method where water is removed by forming ice crystals. This is done by cooling the liquid food below the freezing point of the solution. The freezing point depression is referred as a colligative property and it is proportional to the molar concentration of the solution (m), along with vapor pressure lowering, boiling point elevation, and osmotic pressure. These are physical characteristics of solutions that depend only on the identity of the solvent and the concentration of the solute. The characters are not depending on the solute's identity. (Jayawardena, J. A. E. C., Vanniarachchi, M. P. G., & Wansapala, M. A. J. (2017). Freezing point depression of different Sucrose solutions and coconut water.)

1. When a non volatile solid is added to pure water it will:
 - a. boil above 100°C and freeze above 0°C
 - b. boil below 100°C and freeze above 0°C
 - c. boil above 100°C and freeze below 0°C
 - d. boil below 100°C and freeze below 0°C
2. Colligative properties are:
 - a. dependent only on the concentration of the solute and independent of the solvent's and solute's identity.
 - b. dependent only on the identity of the solute and the concentration of the solute and independent of the solvent's identity.
 - c. dependent on the identity of the solvent and solute and thus on the concentration of the solute.
 - d. dependent only on the identity of the solvent and the concentration of the solute and independent of the solute's identity.
3. Assume three samples of juices A, B and C have glucose as the only sugar present in them. The concentration of sample A, B and C are 0.1M, .5M and 0.2 M respectively. Freezing point will be highest for the fruit juice:
 - a. A
 - b. B
 - c. C
 - d. All have same freezing point
4. Identify which of the following is a colligative property :
 - a. freezing point
 - b. boiling point
 - c. osmotic pressure
 - d. all of the above

Ans 1 (b) 2 (d) 3 (a) 4(c)

(III) Read the passage given below and answer the following questions:

The rate of a reaction, which may also be called its velocity or speed, can be defined with relation to the concentration of any of the reacting substances, or to that of any product of the reaction. If the species chosen is a reactant which has a concentration c at time t the rate is $-dc/dt$, while the rate with reference to a product having a concentration x at time t is dx/dt . Any concentration units may be used for expressing the rate; thus, if moles per liter are employed for concentration and seconds for the time, the units for the rate are moles liter⁻¹sec⁻¹. For gas reactions pressure units are sometimes used in place of concentrations, so that legitimate units for the rate would be (mm. Hg) sec⁻¹ and atm. sec⁻¹

The order of a reaction concerns the dependence of the rate upon the concentrations of reacting substances; thus, if the rate is found experimentally to be proportional to the α^{th} power of the concentration of one of the reactants A, to the β^{th} power of the concentration of a second reactant B, and so forth, via.,

$$\text{rate} = k C_A^\alpha C_B^\beta \quad (1)$$

the over-all order of the reaction is simply

$$n = \alpha + \beta + \dots \quad (2)$$

Such a reaction is said to be of the α^{th} order with respect to the substance A, the β^{th} order with respect to B and so on...

(Laidler, K. J., & Glasstone, S. (1948). Rate, order and molecularity in chemical kinetics. *Journal of Chemical Education*, 25(7), 383.)

In the following questions, a statement of assertion followed by a statement of reason is given. Choose the correct answer out of the following choices on the basis of the above passage.

- A. Assertion and reason both are correct statements and reason is correct explanation for assertion.
- B. Assertion and reason both are correct statements but reason is not correct explanation for assertion.
- C. Assertion is correct statement but reason is wrong statement.
- D. Assertion is wrong statement but reason is correct statement.

1. **Assertion:** Rate of reaction is a measure of change in concentration of reactant with respect to time.

Reason: Rate of reaction is a measure of change in concentration of product with respect to time.

2. **Assertion:** For a reaction: $P + 2Q \rightarrow \text{Products}$, Rate = $k [P]^{1/2}[Q]^1$ so the order of reaction is 1.5

Reason: Order of reaction is the sum of stoichiometric coefficients of the reactants.

3. **Assertion:** The unit of k is independent of order of reaction.

Reason: The unit of k is moles L⁻¹s⁻¹.

4. **Assertion:** Reactions can occur at different speeds.

Reason: Rate of reaction is also called speed of reaction.

Ans: 1B 2C 3D 4B

(IV) Read the passage given below and answer the following questions:

Reduction of carboxylic acids and their derivatives plays an important role in organic synthesis, in both laboratory and industrial processes. Traditionally, the reduction is performed using stoichiometric amounts of hydride reagents, generating stoichiometric amounts of waste. A much more attractive, atom-economical approach is a catalytic reaction using H₂; however, hydrogenation of carboxylic acid derivatives under mild conditions is a very challenging task, with amides presenting the highest challenge among all classes of carbonyl compounds. Very few examples of the important hydrogenation of amides to amines, in which the C-O bond is cleaved with the liberation of water (Scheme 1), were reported. C-O cleavage of amides can also be affected with silanes as reducing agents.

Received September 5, 2010; E-mail: david.milstein@weizmann.

hydrogenation of amides to the
with cleavage of the C-N
products of C-O cleavage
the case of anilides). The
and neutral, homogeneous

Scheme 1. General Sche

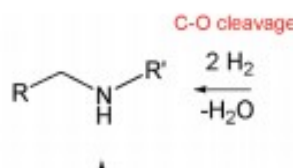

We have now prepared the new, dearomatized, bipyridine-based pincer complex 3, catalyst 3 (Here referred as Cat. 3). Remarkably, it efficiently catalyzes the selective hydrogenation of amides to form amines and alcohols (eq 1). The reaction proceeds under mild pressure and neutral conditions, with no additives being required. Since the reaction proceeds well under anhydrous conditions, hydrolytic cleavage of the amide is not involved in this process.

been reported.⁶ Amines and
chemical, pharmaceutical, and
each a reaction is conceptually
step in amide hydrogenation
carbonyl group to form a very

anhydrous conditions
involved in this pro

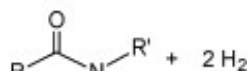

(Balaraman, E., Gnanaprakasam, B., Shimon, L. J., & Milstein, D. (2010). Direct hydrogenation of amides to alcohols and amines under mild conditions. *Journal of the American Chemical Society*, 132(47), 16756-16758.)

In the following questions, a statement of assertion followed by a statement of reason is given. Choose the correct answer out of the following choices on the basis of the above passage.

- A. Assertion and reason both are correct statements and reason is correct explanation for assertion.
- B. Assertion and reason both are correct statements but reason is not correct explanation for assertion.
- C. Assertion is correct statement but reason is wrong statement.
- D. Assertion is wrong statement but reason is correct statement.

- 1. Assertion:** The use of catalyst 3 is an efficient method of preparation of primary amines
Reason: Use of catalyst 3 is a step down reaction.
- 2. Assertion:** Use of hydride catalyst or hydrogen brings about cleavage of C-O bond in amides.
Reason: Hydride catalyst or hydrogen cause to reduction of amides.
- 3. Assertion:** N-methyl ethanamide on reaction with catalyst 3 will yield ethanol and methanamine.
Reason: Use of Catalyst 3 brings about cleavage of C-N bond of amides
- 4. Assertion:** Aniline can be prepared from suitable amide using catalyst 3
Reason: The use of catalyst 3 is limited to aliphatic amides only.

Ans: 1B 2B 3 A 4C

(V) Read the passage given below and answer the following questions:

Nucleophilic substitution reaction of haloalkane can be conducted according to both S_N^1 and S_N^2 mechanisms. However, which mechanism it is based on is related to such factors as the structure of haloalkane, and properties of leaving group, nucleophilic reagent and solvent.

Influences of halogen : No matter which mechanism the nucleophilic substitution reaction is based on, the leaving group always leave the central carbon atom with electron pair. This is just the opposite of the situation that nucleophilic reagent attacks the central carbon atom with electron pair. Therefore, the weaker the alkalinity of leaving group is , the more stable the anion formed is and it will be more easier for the leaving group to leave the central carbon atom; that is to say, the reactant is more easier to be substituted. The alkalinity order of halogen ion is $I^- < Br^- < Cl^- < F^-$ and the order of their leaving tendency should be $I^- > Br^- > Cl^- > F^-$. Therefore, in four halides with the same alkyl and different halogens, the order of substitution reaction rate is $RI > RBr > RCl > RF$. In addition, if the leaving group is very easy to leave, many carbocation intermediates are generated in the reaction and the reaction is based on S_N^1 mechanism. If the leaving group is not easy to leave, the reaction is based on S_N^2 mechanism.

Influences of solvent polarity: In S_N^1 reaction, the polarity of the system increases from the reactant to the transition state, because polar solvent has a greater stabilizing effect on the transition state than the reactant, thereby reduce activation energy and accelerate the reaction. In S_N^2 reaction, the polarity of the system generally does not change from the reactant to the transition state and only charge dispersion occurs. At this time, polar solvent has a great stabilizing effect on Nu than the transition state, thereby increasing activation energy and slow down the reaction rate. For example, the decomposition rate (S_N^1) of tertiary chlorobutane in 25°C water (dielectric constant 79) is 300000 times faster than in ethanol (dielectric constant 24). The reaction rate (S_N^2) of 2-bromopropane and NaOH in ethanol containing 40% water is twice slower than in absolute ethanol. In a word, the level of solvent polarity has influence on both S_N^1 and S_N^2 reactions, but with different results. Generally speaking, weak polar solvent is favorable for S_N^2 reaction, while strong polar solvent is favorable for S_N^1 reaction, because only under the action of polar solvent can halogenated hydrocarbon dissociate into carbocation and halogen ion and solvents with a strong polarity is favorable for solvation of carbocation, increasing its stability. Generally speaking, the substitution reaction of tertiary haloalkane is based on S_N^1 mechanism in solvents with a strong polarity (for example, ethanol containing water).

(Ding, Y. (2013). A Brief Discussion on Nucleophilic Substitution Reaction on Saturated Carbon Atom. In *Applied Mechanics and Materials* (Vol. 312, pp. 433-437). Trans Tech Publications Ltd.)

1. S_N^1 mechanism is favoured in which of the following solvents:
 - a. benzene
 - b. carbon tetrachloride
 - c. acetic acid
 - d. carbon disulphide
2. Nucleophilic substitution will be fastest in case of:
 - a. 1-Chloro-2,2-dimethyl propane

- b. 1-Iodo-2,2-dimethyl propane
 - c. 1-Bromo-2,2-dimethyl propane
 - d. 1-Fluoro-2,2-dimethyl propane
3. S_N^1 reaction will be fastest in which of the following solvents?
- a. Acetone (dielectric constant 21)
 - b. Ethanol (dielectric constant 24)
 - c. Methanol (dielectric constant 32)
 - d. Chloroform (dielectric constant 5)
4. Polar solvents make the reaction faster as they:
- a. destabilize transition state and decrease the activation energy
 - b. destabilize transition state and increase the activation energy
 - c. stabilize transition state and increase the activation energy
 - d. stabilize transition state and decrease the activation energy
5. S_N^1 reaction will be fastest in case of:
- a. 1-Chloro-2-methyl propane
 - b. 1-Iodo-2-methyl propane
 - c. 1-Chlorobutane
 - d. 1-Iodobutane

Ans: 1 c, 2b, 3 c, 4c, 5 b

(VI) Read the passage given below and answer the following questions:

Within the 3d series, manganese exhibits oxidation states in aqueous solution from +2 to +7, ranging from $\text{Mn}^{2+}(\text{aq})$ to $\text{MnO}_4^- (\text{aq})$. Likewise, iron forms both $\text{Fe}^{2+}(\text{aq})$ and $\text{Fe}^{3+}(\text{aq})$ as well as the FeO_4^{2-} ion. Cr and Mn form oxyions CrO_4^{2-} , MnO_4^- , owing to their willingness to form multiple bonds. The pattern with the early transition metals—in the 3d series up to Mn, and for the 4d, 5d metals up to Ru and Os—is that the maximum oxidation state corresponds to the number of “outer shell” electrons. The highest oxidation states of the 3d metals may depend upon complex formation (e.g., the stabilization of Co^{3+} by ammonia) or upon the pH (thus $\text{MnO}_4^{2-} (\text{aq})$ is prone to disproportionation in acidic solution). Within the 3d series, there is considerable variation in relative stability of oxidation states, sometimes on moving from one metal to a neighbor; thus, for iron, Fe^{3+} is more stable than Fe^{2+} , especially in alkaline conditions, while the reverse is true for cobalt. The ability of transition metals to exhibit a wide range of oxidation states is marked with metals such as vanadium, where the standard potentials can be rather small, making a switch between states relatively easy.

(Cotton, S. A. (2011). Lanthanides: Comparison to 3d metals. *Encyclopedia of inorganic and Bioinorganic Chemistry*.)

In the following questions, a statement of assertion followed by a statement of reason is given. Choose the correct answer out of the following choices on the basis of the above passage.

- A. Assertion and reason both are correct statements and reason is correct explanation for assertion.
- B. Assertion and reason both are correct statements but reason is not correct explanation for assertion.
- C. Assertion is correct statement but reason is wrong statement.
- D. Assertion is wrong statement but reason is correct statement.

1. Assertion: Highest oxidation state is exhibited by transition metal lying in the middle of the series.

Reason: The highest oxidation state exhibited corresponds to number of (n-1)d electrons.

2. Assertion: Fe^{3+} is more stable than Fe^{2+}

Reason: Fe^{3+} has $3d^5$ configuration while Fe^{2+} has $3d^6$ configuration.

3. Assertion: Vanadium had the ability to exhibit a wide range of oxidation states.

Reason: The standard potentials Vanadium are rather small, making a switch between oxidation states relatively easy.

4. Assertion: Transition metals like Fe, Cr and Mn form oxyions

Reason: Oxygen is highly electronegative and has a tendency to form multiple bonds.

5.Assertion: The highest oxidation states of the 3d metals depends only on electronic configuration of the metal.

Reason: The number of electrons in the (n-1)d and ns subshells determine the oxidation states exhibited by the metal.

Ans: 1.c 2 a 3 a 4 b 5d

(VII) Read the passage given below and answer the following questions:

Reductive alkylation is the term applied to the process of introducing alkyl groups into ammonia or a primary or secondary amine by means of an aldehyde or ketone in the presence of a reducing agent. The present discussion is limited to those reductive alkylations in which the reducing agent is hydrogen and a catalyst or "nascent" hydrogen, usually from a metal-acid combination; most of these reductive alkylations have been carried out with hydrogen and a catalyst. The principal variation excluded is that in which the reducing agent is formic acid or one of its derivatives; this modification is known as the Leuckart reaction. The process of reductive alkylation of ammonia consists in the addition of ammonia to a carbonyl compound and reduction of the addition compound or its dehydration product. The reaction usually is carried out in ethanol solution when the reduction is to be effected catalytically

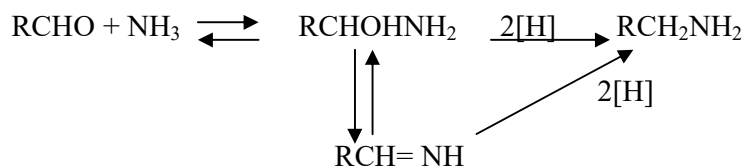

Since the primary amine is formed in the presence of the aldehyde it may react in the same way as ammonia, yielding an addition compound, a Schiff's base ($\text{RCH}=\text{NCH}_2\text{R}$) and finally, a secondary amine. Similarly, the primary amine may react with the imine, forming an addition product which also is reduced to a secondary amine. Finally, the secondary amine may react with either the aldehyde or the imine to give products which are reduced to tertiary amines.

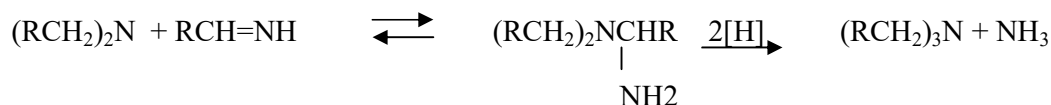
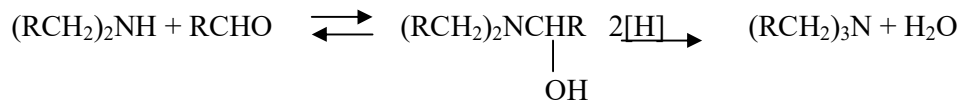
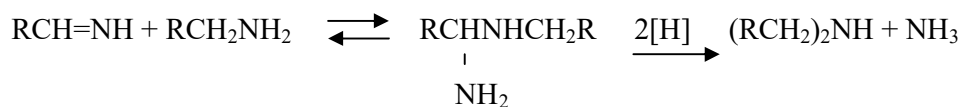

Similar reactions may occur when the carbonyl compound employed is a ketone.

(source: Emerson, W. S. (2011). *The Preparation of Amines by Reductive Alkylation. Organic Reactions, 174–255.* doi:10.1002/0471264180.or004.03)

Q1. Ethanal on reaction with ammonia forms an imine (X) which on reaction with nascent hydrogen gives (Y). Identify 'X' and 'Y'.

- A. X is $\text{CH}_3\text{CH}=\text{NH}$ and Y is CH_3NH_2
- B. X is $\text{CH}_3\text{CHOHNH}_2$ and Y is $\text{CH}_3\text{CH}_2\text{NH}_2$
- C. X is $\text{CH}_3\text{CHOHNH}_2$ and Y is CH_3NH_2
- D. X is $\text{CH}_3\text{CH}=\text{NH}$ and Y is $\text{CH}_3\text{CH}_2\text{NH}_2$

Q2. Acetaldehyde is reacted with ammonia followed by reduction in presence of hydrogen as a catalyst. The primary amine so formed further reacts with acetaldehyde. The Schiff's base formed during the reaction is:

- A. $\text{CH}_3\text{CH}=\text{NHCH}_3$
- B. $\text{CH}_3\text{CH}=\text{NHCH}_2\text{CH}_3$
- C. $\text{CH}_3=\text{NHCH}_2\text{CH}_3$
- D. $\text{CH}_3\text{CH}_2\text{CH}=\text{NHCH}_3$

Q3. The reaction of ammonia and its derivatives with aldehydes is called:

- A. Nucleophilic substitution reaction
- B. Electrophilic substitution reaction
- C. Nucleophilic addition reaction
- D. Electrophilic addition reaction

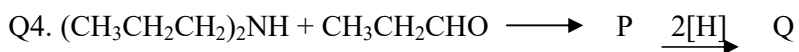

The compound Q is:

- A. $(\text{CH}_3\text{CH}_2\text{CH}_2)_3\text{N}$
- B. $(\text{CH}_3\text{CH}_2\text{CH}_2)_2\text{N}(\text{CH}_2\text{CH}_3)$
- C. $(\text{CH}_3\text{CH}_2)_3\text{N}$
- D. $(\text{CH}_3\text{CH}_2)_2\text{NH}$

Q5. Reductive alkylation of ammonia by means of an aldehyde in presence of hydrogen as reducing agents results in formation of:

- A. Primary amines
- B. Secondary amines
- C. Tertiary amines
- D. Mixture of all three amines

(Ans: 1D,2B,3C,4 A,5D)

(VIII) Read the passage given below and answer the following questions:

Some colloids are stable by their nature, i.e., gels, alloys, and solid foams. Gelatin and jellies are two common examples of a gel. The solid and liquid phases in a gel are interdispersed with both phases being continuous. In most systems, the major factor influencing the stability is the charge on the colloidal particles. If a particular ion is preferentially adsorbed on the surface of the particles, the particles in suspension will repel each other, thereby preventing the formation of aggregates that are larger than colloidal dimensions. The ion can be either positive or negative depending on the particular colloidal system, i.e., air bubbles accumulate negative ions, sulphur particles have a net negative charge in a sulphur sol, and the particles in a metal hydroxide sol are positively charged. Accumulation of charge on a surface is not an unusual phenomenon-dust is attracted to furniture surfaces by electrostatic forces. When salts are added to lyophobic colloidal systems the colloidal particles begin to form larger aggregates and a sediment forms as they settle. This phenomenon is called flocculation, and the suspension can be referred to as flocculated, or colloidal unstable. If the salt is removed, the suspension can usually be restored to its original state; this process is called deflocculation or peptization. The original and restored colloidal systems are called deflocculated, peptized, or stable sols.

Why does a small amount of salt have such a dramatic effect on the stability of a lyophobic colloidal system? The answer lies in an understanding of the attractive and repulsive forces that exist between colloidal particles. Van der Waals forces are responsible for the attractions, while the repulsive forces are due to the surface charge on the particles. In a stable colloid, the repulsive forces are of greater magnitude than the attractive forces. The magnitude of the electrical repulsion is diminished by addition of ionized salt, which allows the dispersed particles to aggregate and flocculate. River deltas provide an example of this behaviour. A delta is formed at the mouth of a river because the colloidal clay particles are flocculated when the freshwater mixes with the salt water of the ocean

(source: Sarquis, J. (1980). *Colloidal systems. Journal of Chemical Education*, 57(8), 602. doi:10.1021/ed057p602)

Q1. Gelatin is a _____ colloidal system.

- A. Solid in solid
- B. Solid in gas
- C. Liquid in solid
- D. Liquid in gas

Q2. Colloidal solutions are stable due to:

- A. presence of charges on the colloidal particles
- B. formation of aggregates by colloidal particles
- C. preferential adsorption on the surface
- D. preferential absorption on the surface

Q3. Settling down of colloidal particles to form a suspension is called:

- A. flocculation
- B. peptization
- C. aggregation
- D. deflocculation

Q4. When Van der Waals forces are greater than forces due to the surface charge on the particles,

- A. flocculation occurs.
- B. the colloid is stable.
- C. peptization takes place.
- D. deflocculation occurs.

Q5. The particles in suspension will repel each other, thereby preventing the formation of aggregates that are larger than colloidal dimensions. This statement explains:

- A. formation of delta
- B. river water is a colloidal of clay particles
- C. effect of salt on lyphobic colloid
- D. phenomenon of flocculation

(Ans: 1C, 2C, 3A,4A,5B)

(IX) Read the passage given below and answer the following questions:

Industrially widely applied esterification reactions are commonly catalysed using mineral liquid acids, such as sulphuric acid and p-toluenesulphonic acid. The catalytic activity of homogeneous catalysts is high. They suffer, however, from several drawbacks, such as their corrosive nature, the existence of side reactions, and the fact that the catalyst cannot be easily separated from the reaction mixture. The use of solid acid catalysts offers an alternative and has received a lot of attention in the past years. Solid acid catalysts are not corrosive and, coated onto a support, they can be easily reused. Examples of solid acid catalysts used in esterification reactions include ion-exchange resins, zeolites and superacids like sulphated zirconia and niobium acid. Ion-exchange resins are the most common heterogeneous catalysts used and have proven to be effective in liquid phase esterification and etherification reactions. Because of their selective adsorption of reactants and swelling nature, these resins not only catalyse the esterification reaction but also affect the equilibrium conversion. Shortcomings include insufficient thermal resistance, which limits the reaction temperature to 120 °C, preventing widespread use in industry. Zeolites, like Y, X, BEA, ZSM-5 and MCM-41 offer an interesting alternative and have proven to be efficient catalysts for esterification reactions. Zeolites have found wide application in oil refining, petrochemistry and in the production of fine chemicals. Their success is based on the possibility to prepare zeolites with strong Brønsted acidity that can be controlled within a certain range, combined with a good resistance to high reaction temperatures.

In this study, the activity of various commercial available solid acid catalysts is assessed with respect to the esterification of acetic acid with butanol. The ion-exchange resins Amberlyst 15 and Smopex-101, the acid zeolites H-ZSM-5, H-MOR, H-BETA and H-USY, and the solid superacids sulphated zirconia and niobium acid are selected. Comparative esterification experiments have been carried out using the homogeneous catalysts sulphuric acid, p-toluenesulphuric acid and a heteropolyacid (HPA).

The weight-based activity of the heterogeneous catalysts tested is maximum for Smopex101. The following table gives the activity of different catalysts in the esterification reaction between acetic acid and butanol at 75⁰C.

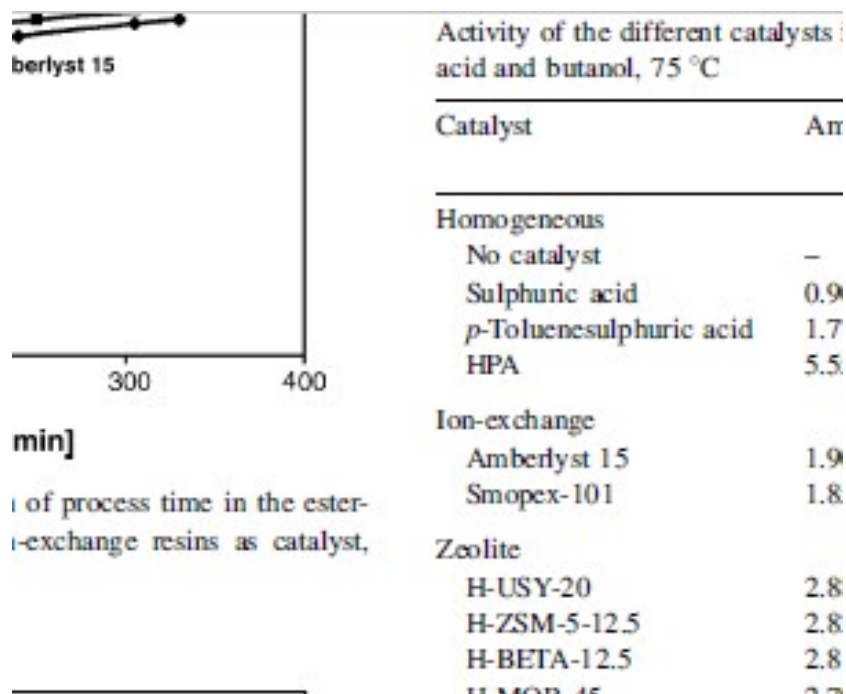

Here: k_{obs} : observed reaction rate constant ($\text{m}^3 \text{mol}^{-1} \text{s}^{-1}$)
 k_c : catalysed reaction rate constant ($\text{m}^3 \text{mol}^{-1} \text{g}_{cat}^{-1} \text{s}^{-1}$)
 Please note: $k_c = k_{obs} / \text{amount (in g)}$

(source: PETERS, T., BENES, N., HOLMEN, A., & KEURENTJES, J. (2006). *Comparison of commercial solid acid catalysts for the esterification of acetic acid with butanol. Applied Catalysis A: General*, 297(2), 182–188. doi:10.1016/j.apcata.2005.09.00)

Q1. Which of the following are heterogeneous catalysts for esterification reaction:

- A. sulphuric acid and *p*-toluenesulphonic acid
- B. sulphuric acid and niobium acid
- C. *p*-toluenesulphonic acid and niobium acid
- D. niobium acid and sulphated zirconia

Q2. Unit for observed rate constant for esterification reaction is $\text{m}^3 \text{mol}^{-1} \text{s}^{-1}$, so the reaction is:

- A. zero order
- B. first order
- C. second order
- D. third order

Q3. The catalytic activity of homogeneous catalysts is high. The weight based activity of HPA is less than which of the following heterogeneous catalysts?

- A. Smopex-101
- B. Amberlyst 15
- C. sulphated ZrO_2

D. H-USY-20

Q4. The weight-based activity of the heterogeneous catalysts tested decreases in the following order:

- A. Smopex-101 > Amberlyst 15 > sulphated ZrO₂ > H-USY-20 > H-BETA-12.5 > H-MOR-45 > Nb₂O₅ > H-ZSM-5-12
- B. Smopex-101 > Amberlyst 15 > sulphated ZrO₂ > H-USY-20 > H-BETA-12.5 > H-MOR-45 > H-ZSM-5-12 > Nb₂O₅
- C. Smopex-101 > Amberlyst 15 > sulphated ZrO₂ > H-USY-20 > H-BETA-12.5 > Nb₂O₅ > H-MOR-45 > H-ZSM-5-12
- D. Smopex-101 > sulphated ZrO₂ > Amberlyst 15 > H-USY-20 > H-BETA-12.5 > H-MOR-45 > H-ZSM-5-12 > Nb₂O₅

Q5. Catalysts used in oil refining industry are:

- A. ion exchange resins
- B. superacids
- C. zeolites
- D. mineral liquid acids

(ANS: 1D, 2C, 3A, 4A, 5C)

(X) Read the passage given below and answer the following questions:

Biopolymers are polymers that are generated from renewable natural sources, are often biodegradable and nontoxic. They can be produced by biological systems (i.e. microorganisms, plants and animals), or chemically synthesized from biological materials (e.g., sugars, starch, natural fats or oils, etc.). Two strategies are applied in converting these raw materials into biodegradable polymers: extraction of the native polymer from a plant or animal tissue, and a chemical or biotechnological route of monomer polymerization. Biodegradable biopolymers (BDP) are an alternative to petroleum-based polymers (traditional plastics). Some BDP degrade in only a few weeks, while the degradation of others takes several months. In principle the properties relevant for application as well as biodegradability are determined by the molecular structure. According to the American Society for Testing and Materials, biopolymers are degradable polymers in which degradation results from the action of naturally occurring microorganisms such as bacteria, fungi and algae .

Poly(lactic acid) (PLA) is an example of biopolymer. It is a thermoplastic polyester. Generally, there are two major routes to produce poly(lactic acid) from the lactic acid ($\text{CH}_3\text{CH}(\text{OH})\text{COOH}$) monomer. The first route involves condensation–water removal by the use of solvent under high vacuum and temperature. This approach produces a low to intermediate molar mass polymer. An alternative method is to remove water under milder conditions, without solvent, to produce a cyclic intermediate dimer, referred to as lactide. This intermediate is readily purified by vacuum distillation. Ring opening polymerization of the dimer is accomplished under heat, again without the need for solvent. By controlling the purity of the dimer it is possible to produce a wide range of molar masses .PLA is a good material for production of clothing, carpet tiles, interior and outdoor furnishing, geotextiles, bags, filtration systems, etc.

The primary biodegradability of PLA was tested using hydrolysis tests at various composting temperatures and pH. It was demonstrated that composting is a useful method for PLA biodegradation. The degradation rate is very slow in ambient temperatures. A 2017 study found that at 25 °C in sea water, PLA showed no degradation over a year. As a result, it is poorly degraded in landfills and household composts, but is effectively digested in hotter industrial composts.

(source: Flieger, M., Kantorová, M., Prell, A., Řezanka, T., & Votruba, J. (2003). *Biodegradable plastics from renewable sources. Folia Microbiologica*, 48(1), 27–44. doi:10.1007/bf02931273)

In the following questions, a statement of assertion followed by a statement of reason is given. Choose the correct answer out of the following choices on the basis of the above passage.

- A. Assertion and reason both are correct statements and reason is correct explanation for assertion.
- B. Assertion and reason both are correct statements but reason is not correct explanation for assertion.

- C. Assertion is correct statement but reason is wrong statement.
- D. Assertion is wrong statement but reason is correct statement.

Q1. Assertion: Biodegradable polymers degrade in few weeks.

Reason: Microorganisms bring about degradation of biopolymers.

Q2. Assertion: Lactic acid on polymerisation forms

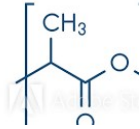

Reason: PLA is used in producing geotextiles.

Q3. Assertion: Lactic acid undergoes condensation polymerisation

Reason: Lactic acid is a bifunctional monomeric unit.

Q4. Assertion: . The degradation of PLA is very slow in ambient temperature.

Reason: PLA is a thermoplastic.

Q5. Assertion: PLA is poorly degraded in landfills.

Reason: The degradation rate of PLA is very slow in ambient temperatures.

(ANS: 1D, 2B, 3A,4B,5A)

(XI) Read the passage given below and answer the following questions:

In the last 10 years much has been learned about the molecular structure of elemental sulfur. It is now known that many different types of rings are sufficiently metastable to exist at room temperature for several days. It is known that at high temperature, the equilibrium composition allows for a variety of rings and chains to exist in comparable concentration, and it is known that at the boiling point and above, the vapor as well as the liquid contains small species with three, four, and five atoms.

The sulfur atom has the same number of valence electrons as oxygen. Thus, sulfur atoms S_2 and S_3 have physical and chemical properties analogous to those of oxygen and ozone. S_2 has a ground state of $3\sigma 3s^2 \sigma^* 3s^2 \sigma 3p_z^2 \pi 3p_x^2 = \pi 3p_y^2 \pi^* 3p_x^1 = \pi^* 3p_y^1$. S_3 , thiozone has a well-known uv spectrum, and has a bent structure, analogous to its isovalent molecules O_3 , SO_2 , and S_2O . The chemistry of the two elements, sulphur and oxygen, differs because sulfur has a pronounced tendency for catenation. The most frequently quoted explanation is based on the electron structure of the atom. Sulfur has low-lying unoccupied 3d orbitals, and it is widely believed that the 4s and 3d orbitals of sulfur participate in bonding in a manner similar to the participation of 2s and 2p orbitals in carbon.

(source: Meyer, B. (1976). *Elemental sulfur. Chemical Reviews*, 76(3), 367–388. doi:10.1021/cr60301a003)

In the following questions, a statement of assertion followed by a statement of reason is given. Choose the correct answer out of the following choices on the basis of the above passage.

- A. Assertion and reason both are correct statements and reason is correct explanation for assertion.
- B. Assertion and reason both are correct statements but reason is not correct explanation for assertion.
- C. Assertion is correct statement but reason is wrong statement.
- D. Assertion is wrong statement but reason is correct statement.

Q1 Assertion: Sulphur belongs to same group in the periodic table as oxygen.

Reason: S_2 has properties analogous to O_2 .

Q2. Assertion: Thiozone has bent structure like ozone.

Reason: Ozone has a lone pair which makes the molecule bent.

Q3. Assertion: S_2 is paramagnetic in nature

Reason: The electrons in $\pi^* 3p_x$ and $\pi^* 3p_y$ orbitals in S_2 are unpaired.

Q4. Assertion: Sulphur has a greater tendency for catenation than oxygen.

Reason: 3d and 4s orbitals of Sulphur have same energy.

(ANS: 1B,2B, 3A,4C)

(XII) Read the passage given below and answer the following questions:

Adenosine triphosphate (ATP) is the energy-carrying molecule found in the cells of all living things. ATP captures chemical energy obtained from the breakdown of food molecules and releases it to fuel other cellular processes. ATP is a nucleotide that consists of three main structures: the nitrogenous base, adenine; the sugar, ribose; and a chain of three phosphate groups bound to ribose. The phosphate tail of ATP is the actual power source which the cell taps. Available energy is contained in the bonds between the phosphates and is released when they are broken, which occurs through the addition of a water molecule (a process called hydrolysis). Usually only the outer phosphate is removed from ATP to yield energy; when this occurs ATP is converted to adenosine diphosphate (ADP), the form of the nucleotide having only two phosphates.

The importance of ATP (adenosine triphosphate) as the main source of chemical energy in living matter and its involvement in cellular processes has long been recognized. The primary mechanism whereby higher organisms, including humans, generate ATP is through mitochondrial oxidative phosphorylation. For the majority of organs, the main metabolic fuel is glucose, which in the presence of oxygen undergoes complete combustion to CO₂ and H₂O:



The free energy (ΔG) liberated in this exergonic (ΔG is negative) reaction is partially trapped as ATP in two consecutive processes: glycolysis (cytosol) and oxidative phosphorylation (mitochondria). The first produces 2 mol of ATP per mol of glucose, and the second 36 mol of ATP per mol of glucose. Thus, oxidative phosphorylation yields 17-18 times as much useful energy in the form of ATP as can be obtained from the same amount of glucose by glycolysis alone.

The efficiency of glucose metabolism is the ratio of amount of energy produced when 1 mol of glucose oxidised in cell to the enthalpy of combustion of glucose. The energy lost in the process is in the form of heat. This heat is responsible for keeping us warm.

(source: Erecińska, M., & Silver, I. A. (1989). ATP and Brain Function. *Journal of Cerebral Blood Flow & Metabolism*, 9(1), 2–19. <https://doi.org/10.1038/jcbfm.1989.2> and <https://www.britannica.com/science/adenosine-triphosphate>)

Q1. Cellular oxidation of glucose is a:

- A. spontaneous and endothermic process
- B. non spontaneous and exothermic process
- C. non spontaneous and endothermic process
- D. spontaneous and exothermic process

Q2. What is the efficiency of glucose metabolism if 1 mole of glucose gives 38ATP energy?(Given: The enthalpy of combustion of glucose is 686 kcal, 1ATP= 7.3kcal)

- A. 100%
- B. 38%
- C. 62%
- D. 80%

Q3. Which of the following statement is true?

- A. ATP is a nucleoside made up of nitrogenous base adenine and ribose sugar .
- B. ATP consists the nitrogenous base, adenine and the sugar, deoxyribose.
- C. ATP is a nucleotide which contains a chain of three phosphate groups bound to ribose sugar.
- D. The nitrogenous base of ATP is the actual power source.

Q4. Nearly 95% of the energy released during cellular respiration is due to:

- A. glycolysis occurring in cytosol
- B. oxidative phosphorylation occurring in cytosol
- C. glycolysis in occurring mitochondria
- D. oxidative phosphorylation occurring in mitochondria

Q5. Which of the following statements is correct:

- A. ATP is a nucleotide which has three phosphate groups while ADP is a nucleoside which three phosphate groups.
- B. ADP contains a nitrogenous bases adenine, ribose sugar and two phosphate groups bound to ribose.
- C. ADP is the main source of chemical energy in living matter.
- D. ATP and ADP are nucleosides which differ in number of phosphate groups.

(ANS: 1D,2B(Glucose catabolism yields a TOTAL of 38 ATP. $38 \text{ ATP} \times 7.3 \text{ kcal/mol ATP} = 262 \text{ kcal}$. Glucose has 686 kcal. Thus the efficiency of glucose metabolism is $262/686 \times 100 = 38\%$.) ,3C,4D,5B)

(XIII) Read the passage given below and answer the following questions:

The transition metals when exposed to oxygen at low and intermediate temperatures form thin, protective oxide films of up to some thousands of Angstroms in thickness. Transition metal oxides lie between the extremes of ionic and covalent binary compounds formed by elements from the left or right side of the periodic table. They range from metallic to semiconducting and deviate by both large and small degrees from stoichiometry. Since d-electron bonding levels are involved, the cations exist in various valence states and hence give rise to a large number of oxides. The crystal structures are often classified by considering a cubic or hexagonal close-packed lattice of one set of ions with the other set of ions filling the octahedral or tetrahedral interstices. The actual oxide structures, however, generally show departures from such regular arrays due in part to distortions caused by packing of ions of different size and to ligand field effects. These distortions depend not only on the number of d-electrons but also on the valence and the position of the transition metal in a period or group. (source: Smeltzer, W. W., & Young, D. J. (1975). Oxidation properties of transition metals. *Progress in Solid State Chemistry*, 10, 17-54.)

In the following questions, a statement of assertion followed by a statement of reason is given. Choose the correct answer out of the following choices on the basis of the above passage.

- A. Assertion and reason both are correct statements and reason is correct explanation for assertion.
- B. Assertion and reason both are correct statements but reason is not correct explanation for assertion.
- C. Assertion is correct statement but reason is wrong statement.
- D. Assertion is wrong statement but reason is correct statement.

1. Assertion: Cations of transition elements occur in various valence states

Reason: Large number of oxides of transition elements are possible.

2. Assertion: Crystal structure of oxides of transition metals often show defects.

Reason: Ligand field effect cause distortions in crystal structures.

3. Assertion : Transition metals form protective oxide films.

Reason: Oxides of transition metals are always stoichiometric.

4. Assertion: CrO₂ crystallises in a hexagonal close-packed array of oxide ions with two out of every three octahedral holes occupied by chromium ions.

Reason: Transition metal oxide may be hexagonal close-packed lattice of oxide ions with metal ions filling the octahedral voids.

(ANS: 1 B , 2 A, 3C , 4D)

(XIV) Read the passage given below and answer the following questions:

The d block elements are the 40 elements contained in the four rows of ten columns (3-12) in the periodic table. As all the d block elements are metallic, the term d-block metals is synonymous. This set of d-block elements is also often identified as the transition metals, but sometimes the group 12 elements (zinc, cadmium, mercury) are excluded from the transition metals as the transition elements are defined as those with partly filled d or f shells in their compounds. Inclusion of the elements zinc, cadmium and mercury is necessary as some properties of the group 12 elements are appropriate logically to include with a discussion of transition metal chemistry.

The term transition element or transition metal appeared to derive from early studies of periodicity such as the Mendeleev periodic table of the elements. His horizontal table of the elements was an attempt to group the elements together so that the chemistry of elements might be explained and predicted. In this table there are eight groups labeled I-VIII with each subdivided into A and B subgroups. Mendeleev recognized that certain properties of elements in Group VIII are related to those of some of the elements in Group VII and those at the start of the next row Group I. In that sense, these elements might be described as possessing properties transitional from one row of the table to the next. (source: Winter, M. J. (2015). *D-block Chemistry* (Vol. 27). Oxford University Press, USA.)

In the following questions, a statement of assertion followed by a statement of reason is given. Choose the correct answer out of the following choices on the basis of the above passage.

- A. Assertion and reason both are correct statements and reason is correct explanation for assertion.
- B. Assertion and reason both are correct statements but reason is not correct explanation for assertion.
- C. Assertion is correct statement but reason is wrong statement.
- D. Assertion is wrong statement but reason is correct statement.

1. Assertion: Group 12 elements are not considered as transition metals.

Reason: Transition metals are those which have incompletely filled d shell in their compounds.

2. Assertion: All d block elements are metallic in nature.

Reason: The d –block elements belong to Group 3 -12 of the periodic table.

3. Assertion : Group VIII elements of Mendeleev periodic table are transition elements.

Reason: Group I –VIII in Mendeleev periodic table is divided into two subgroups, A and B.

4. Assertion: Nickel is a transition element that belongs to group 10 and period 4 of the modern periodic table.

Reason: Electronic configuration of Nickel is $[\text{Ar}]_{18}3d^84s^2$

(ANS: 1A, 2B, 3D,4A)

(XV) Read the passage given below and answer the following questions:

EVIDENCE FOR THE FIBROUS NATURE OF DNA

The basic chemical formula of DNA is now well established. As shown in Figure 1 it consists of a very long chain, the backbone of which is made up of alternate sugar and phosphate groups, joined together in regular 3' 5' phosphate di-ester linkages. To each sugar is attached a nitrogenous base, only four different kinds of which are commonly found in DNA. Two of these---adenine and guanine--- are purines, and the other two thymine and cytosine---are pyrimidines. A fifth base, 5-methyl cytosine, occurs in smaller amounts in certain organisms, and a sixth, 5-hydroxy-methyl-cytosine, is found instead of cytosine in the T even phages. It should be noted that the chain is unbranched, a consequence of the regular internucleotide linkage. On the other hand the sequence of the different nucleotides is, as far as can be ascertained, completely irregular. Thus, DNA has some features which are regular, and some which are irregular. A similar conception of the DNA molecule as a long thin fiber is obtained from physicochemical analysis involving sedimentation, diffusion, light scattering, and viscosity measurements. These techniques indicate that DNA is a very asymmetrical structure approximately 20 A wide and many thousands of angstroms long. Estimates of its molecular weight currently center between 5×10^6 and 10^7 (approximately 3×10^4 nucleotides). Surprisingly each of these measurements tend to suggest that the DNA is relatively rigid, a puzzling finding in view of the large number of single bonds (5 per nucleotide) in the phosphate-sugar back bone. Recently these indirect inferences have been confirmed by electron microscopy.

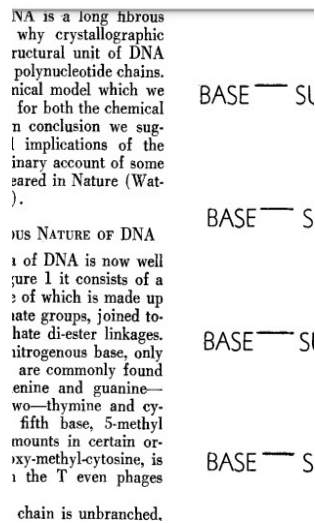

Figure 1

(source: Watson, J. D., & Crick, F. H. (1953, January). The structure of DNA. In *Cold Spring Harbor symposia on quantitative biology* (Vol. 18, pp. 123-131). Cold Spring Harbor Laboratory Press.)

1. Purines present in DNA are:

- A. adenine and thymine
- B. guanine and thymine
- C. cytosine and thymine
- D. adenine and guanine**

2. DNA molecule has _____ internucleotide linkage and _____ sequence of the different nucleotides

- A. regular , regular
- B. regular , irregular
- C. irregular , regular
- D. irregular , irregular**

3. DNA has a _____ backbone

- A. phosphate -purine
- B. pyrimidines- sugar
- C. phosphate- sugar
- D. purine- pyrimidine**

4. Out of the four different kinds of nitrogenous bases which are commonly found in DNA, _____ has been replaced in some organisms.

- A. adenine
- B. guanine
- C. cytosine
- D. thymine**

(ANS 1D, 2 B, 3 C, 4 C)

(XVI) Read the passage given below and answer the following questions:

Polysaccharides may be very large molecules. Starch, glycogen, cellulose, and chitin are examples of polysaccharides.

Starch is the stored form of sugars in plants and is made up of amylose and amylopectin (both polymers of glucose). Amylose is soluble in water and can be hydrolyzed into glucose units breaking glycosidic bonds, by the enzymes α -amylase and β -amylase. It is straight chain polymer. Amylopectin is a branched chain polymer of several D-glucose molecules. 80% of amylopectin is present in starch. Plants are able to synthesize glucose, and the excess glucose is stored as starch in different plant parts, including roots and seeds. The starch that is consumed by animals is broken down into smaller molecules, such as glucose. The cells can then absorb the glucose.

Glycogen is the storage form of glucose in humans and other vertebrates, and is made up of monomers of glucose. It is structurally quite similar to amylopectin. Glycogen is the animal equivalent of starch. It is stored in liver and skeletal muscles.

Cellulose is one of the most abundant natural biopolymers. The cell walls of plants are mostly made of cellulose, which provides structural support to the cell. Wood and paper are mostly cellulosic in nature.

Like amylose, cellulose is a linear polymer of glucose. Cellulose is made up of glucose monomers that are linked by bonds between particular carbon atoms in the glucose molecule. Every other glucose monomer in cellulose is flipped over and packed tightly as extended long chains. This gives cellulose its rigidity and high tensile strength—which is so important to plant cells. Cellulose passing through our digestive system is called dietary fiber.

(Source: <https://chem.libretexts.org>)

1. In animals, Glycogen is stored in :
 - A. Liver
 - B. Spleen
 - C. Lungs
 - D. Small Intestine
2. Amylose is :
 - A. straight chain, water insoluble component of starch, which constitutes 20 % of it.
 - B. straight chain, water soluble component of starch, which constitutes 20 % of it.
 - C. branched chain, water insoluble component of starch, which constitutes 80 % of it.
 - D. branched chain, water soluble component of starch, which constitutes 80 % of it.
3. Which biopolymer breaks down to release glucose, whenever glucose levels drop in Our body :
 - A. starch
 - B. cellulose
 - C. chitin

- D. glycogen
4. The linkages which join monosaccharides to form long chain polysaccharides :
- A. Peptide linkage
 - B. Disulphide bonds
 - C. Hydrogen bonds
 - D. Glycosidic linkage
5. Cellulose on complete hydrolysis yields:
- A. amylose
 - B. amylopectin
 - C. glucose
 - D. amylose and amylopectin

(ANS 1 A,2B,3D, 4D,5C)

CLASS XII (2023-24) (THEORY)

Time: 03 Hours

Max. Marks: 70

Unit	Title	Marks
VI	Reproduction	16
VII	Genetics and Evolution	20
VIII	Biology and Human Welfare	12
IX	Biotechnology and its Applications	12
X	Ecology and Environment	10
	Total	70

Unit-VI Reproduction

Chapter-2: Sexual Reproduction in Flowering Plants

Flower structure; development of male and female gametophytes; pollination - types, agencies and examples; out breeding devices; pollen-pistil interaction; double fertilization; post fertilization events - development of endosperm and embryo, development of seed and formation of fruit; special modes- apomixis, parthenocarpy, polyembryony; Significance of seed dispersal and fruit formation.

Chapter-3: Human Reproduction

Male and female reproductive systems; microscopic anatomy of testis and ovary; gametogenesis -spermatogenesis and oogenesis; menstrual cycle; fertilisation, embryo development upto blastocyst formation, implantation; pregnancy and placenta formation (elementary idea); parturition (elementary idea); lactation (elementary idea).

Chapter-4: Reproductive Health

Need for reproductive health and prevention of Sexually Transmitted Diseases (STDs); birth control - need and methods, contraception and medical termination of pregnancy (MTP); amniocentesis; infertility and assisted reproductive technologies - IVF, ZIFT, GIFT (elementary idea for general awareness).

Unit-VII Genetics and Evolution

Chapter-5: Principles of Inheritance and Variation

Heredity and variation: Mendelian inheritance; deviations from Mendelism – incomplete dominance, co-dominance, multiple alleles and inheritance of blood groups, pleiotropy; elementary idea of polygenic inheritance; chromosome theory of inheritance; chromosomes and genes; Sex determination - in humans, birds and honey bee; linkage and crossing over; sex linked inheritance - haemophilia, colour blindness; Mendelian disorders in humans - thalassemia; chromosomal disorders in humans; Down's syndrome, Turner's and Klinefelter's syndromes.

Chapter-6: Molecular Basis of Inheritance

Search for genetic material and DNA as genetic material; Structure of DNA and RNA; DNA packaging; DNA replication; Central Dogma; transcription, genetic code, translation; gene

expression and regulation - lac operon; Genome, Human and rice genome projects; DNA fingerprinting.

Chapter-7: Evolution

Origin of life; biological evolution and evidences for biological evolution (paleontology, comparative anatomy, embryology and molecular evidences); Darwin's contribution, modern synthetic theory of evolution; mechanism of evolution - variation (mutation and recombination) and natural selection with examples, types of natural selection; Gene flow and genetic drift; Hardy - Weinberg's principle; adaptive radiation; human evolution.

Unit-VIII Biology and Human Welfare

Chapter-8: Human Health and Diseases

Pathogens; parasites causing human diseases (malaria, dengue, chikungunya, filariasis, ascariasis, typhoid, pneumonia, common cold, amoebiasis, ring worm) and their control; Basic concepts of immunology - vaccines; cancer, HIV and AIDS; Adolescence - drug and alcohol abuse.

Chapter-10: Microbes in Human Welfare

Microbes in food processing, industrial production, sewage treatment, energy generation and microbes as bio-control agents and bio-fertilizers. Antibiotics; production and judicious use.

Unit-IX Biotechnology and its Applications

Chapter-11: Biotechnology - Principles and Processes

Genetic Engineering (Recombinant DNA Technology).

Chapter-12: Biotechnology and its Applications

Application of biotechnology in health and agriculture: Human insulin and vaccine production, stem cell technology, gene therapy; genetically modified organisms - Bt crops; transgenic animals; biosafety issues, biopiracy and patents.

Unit-X Ecology and Environment

Chapter-13: Organisms and Populations

Population interactions - mutualism, competition, predation, parasitism; population attributes - growth, birth rate and death rate, age distribution. (Topics excluded: Organism and its Environment, Major Abiotic Factors, Responses to Abiotic Factors, Adaptations)

Chapter-14: Ecosystem

Ecosystems: Patterns, components; productivity and decomposition; energy flow; pyramids of number, biomass, energy (Topics excluded: Ecological Succession and Nutrient Cycles).

Chapter-15: Biodiversity and its Conservation

Biodiversity-Concept, patterns, importance; loss of biodiversity; biodiversity conservation; hotspots, endangered organisms, extinction, Red Data Book, Sacred Groves, biosphere reserves, national parks, wildlife, sanctuaries and Ramsar sites.

PRACTICALS

Time allowed: 3 Hours

Max. Marks: 30

Evaluation Scheme	Marks
One Major Experiment 5	5
One Minor Experiment 2 & 3	4
Slide Preparation 1 & 4	5
Spotting	7
Practical Record + Viva Voce	4
Investigatory Project and its Project Record + Viva Voce (Credit to the student's work over the academic session may be given)	5
Total	30

A. List of Experiments

1. Prepare a temporary mount to observe pollen germination.
2. Study the plant population density by quadrat method.
3. Study the plant population frequency by quadrat method.
4. Prepare a temporary mount of onion root tip to study mitosis.
5. Isolate DNA from available plant material such as spinach, green pea seeds, papaya, etc.

B. Study and observe the following (Spotting):

1. Flowers adapted to pollination by different agencies (wind, insects, birds).
2. Pollen germination on stigma through a permanent slide or scanning electron micrograph.
3. Identification of stages of gamete development, i.e., T.S. of testis and T.S. of ovary through permanent slides (from grasshopper/mice).
4. Meiosis in onion bud cell or grasshopper testis through permanent slides.
5. T.S. of blastula through permanent slides (Mammalian).
6. Mendelian inheritance using seeds of different colour/sizes of any plant.
7. Prepared pedigree charts of any one of the genetic traits such as rolling of tongue, blood groups, ear lobes, widow's peak and colour blindness.
8. Controlled pollination - emasculation, tagging and bagging.
9. Common disease causing organisms like *Ascaris*, *Entamoeba*, *Plasmodium*, any fungus causing ringworm through permanent slides, models or virtual images or specimens. Comment on symptoms of diseases that they cause.

10. Models specimen showing symbolic association in root modules of leguminous plants, Cuscuta on host, lichens.
11. Flash cards models showing examples of homologous and analogous organs.

**Practical Examination for Visually Impaired Students of Classes XI and XII
Evaluation Scheme**

Time: 02 Hours

Max. Marks: 30

Topic	Marks
Identification/Familiarity with the apparatus	5
Written test (Based on given / prescribed practicals)	10
Practical Records	5
Viva	10
Total	30

General Guidelines

- The practical examination will be of two hour duration. A separate list of ten experiments is included here.
- The written examination in practicals for these students will be conducted at the time of practical examination of all other students.
- The written test will be of 30 minutes duration.
- The question paper given to the students should be legibly typed. It should contain a total of 15 practical skill based very short answer type questions. A student would be required to answer any 10 questions.
- A writer may be allowed to such students as per CBSE examination rules.
- All questions included in the question paper should be related to the listed practicals. Every question should require about two minutes to be answered.
- These students are also required to maintain a practical file. A student is expected to record at least five of the listed experiments as per the specific instructions for each subject. These practicals should be duly checked and signed by the internal examiner.
- The format of writing any experiment in the practical file should include aim, apparatus required, simple theory, procedure, related practical skills, precautions etc.
- Questions may be generated jointly by the external/internal examiners and used for assessment.
- The viva questions may include questions based on basic theory / principle / concept, apparatus / materials / chemicals required, procedure, precautions, sources of error etc.

Class XII

- A. Items for Identification/ familiarity with the apparatus for assessment in practicals (All experiments)** Beaker, flask, petriplates, soil from different sites - sandy, clayey, loamy, small potted plants, aluminium foil, paint brush, test tubes, starch solution, iodine, ice cubes, Bunsen burner/spirit lamp/water bath, large flowers, Maize inflorescence, model of developmental stages highlighting morula and blastula of frog, beads/seeds of different shapes/size/texture *Ascaris*, Cactus/*Opuntia*(model).

B. List of Practicals

1. Study of flowers adapted to pollination by different agencies (wind, insects).
2. Identification of T.S of morula or blastula of frog (Model).
3. Study of Mendelian inheritance pattern using beads/seeds of different sizes/texture.
4. Preparation of pedigree charts of genetic traits such as rolling of tongue, colour blindness.
5. Study of emasculation, tagging and bagging by trying out an exercise on controlled pollination.
6. Identify common disease causing organisms like *Ascaris* (model) and learn some common symptoms of the disease that they cause.
7. Comment upon the morphological adaptations of plants found in xerophytic conditions.

Note: The above practicals may be carried out in an experiential manner rather than recording observations.

Prescribed Books:

1. Biology, Class-XII, Published by NCERT
2. Other related books and manuals brought out by NCERT (consider multimedia also)
3. Biology Supplementary Material (Revised). Available on CBSE website.

Question Paper Design (Theory) 2023-24

Class XII

Biology (044)

Competencies	
Demonstrate Knowledge and Understanding	50%
Application of Knowledge / Concepts	30%
Analyse, Evaluate and Create	20%

Note:

- Typology of questions: VSA including MCQs, Assertion – Reasoning type questions; SA; LA-I; LA-II; Source-based/ Case-based/ Passage-based/ Integrated assessment questions.
- An internal choice of approximately 33% would be provided.

Suggestive verbs for various competencies

- **Demonstrate, Knowledge and Understanding**
State, name, list, identify, define, suggest, describe, outline, summarize, etc.
- **Application of Knowledge/Concepts**
Calculate, illustrate, show, adapt, explain, distinguish, etc.
- **Analyze, Evaluate and Create**
Interpret, analyse, compare, contrast, examine, evaluate, discuss, construct, etc.

MARKING SCHEME (2023-24)
Class XII
Biology (Subject Code-044)

Q. No.	Answer	Marks
Section - A		
1	d) black pepper	1
2	d) tapetum	1
3	d) 7	1
4	a) males and females, respectively	1
5	a) 0.32	1
6	a) random and directionless	1
7	d) Nucleotide	1
8	d) aa	1
9	c) Cyclosporin A produced from <i>Trichoderma polysporum</i>	1
10	d)	1
11	b) Reduce pesticide accumulation in food chain	1
12	d) Soil Sample C	1
13	d) A is false but R is true	1
14	c) A is true but R is false	1
15	a) Both A and R are true and R is the correct explanation of A.	1
16	a) Both A and R are true and R is the correct explanation of A.	1
Section – B		
17	<p>Spermatogenesis starts at the age of puberty due to significant increase in the secretion of gonadotropin releasing hormone (GnRH). This is a hypothalamic hormone. [0.5]</p> <p>The increased levels of GnRH then act at the anterior pituitary gland and stimulate secretion of two gonadotropins – luteinising hormone (LH) and follicle stimulating hormone (FSH). [0.5]</p> <p>LH acts at the Leydig cells and stimulates synthesis and secretion of androgens. Androgens, in turn, stimulate the process of spermatogenesis. [0.5]</p> <p>FSH acts on the Sertoli cells and stimulates secretion of some factors which help in the process of spermiogenesis. [0.5]</p>	2
18	<p>a) CTT would become CAT which codes for valine. Thus, valine would replace glutamic acid at that point. [0.5]</p> <p>b) Sickle cell anaemia [0.5], the mutant haemoglobin molecule undergoes polymerization [0.5] leading to the change in the shape of the RBC from biconcave disc to elongated sickle like structure. [0.5]</p>	2

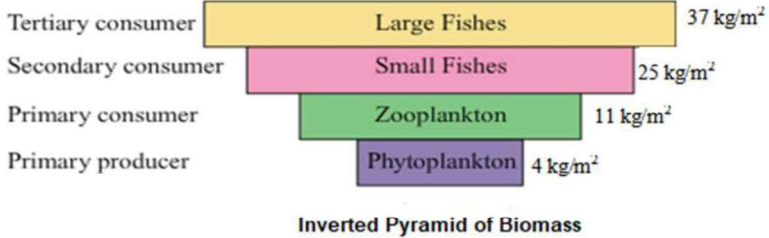
19	<p>On administration of the first dose of the vaccine (L), the body shows a response of low intensity (X) as the immune system comes in contact with the antigenic protein of the weakened/inactivated pathogen for the first time. This is called primary immune response. [1]</p> <p>On subsequent encounter with the same antigenic protein in the second dose (M), the body elicits a highly intensified secondary response (Y). Because of the memory of the first contact with the antigen, the secondary immune response is faster and stronger, leading to more effective pathogen elimination in comparison to the primary immune response. [1]</p>	2
20	<p>a) Plate I, b-galactosidase enzyme is responsible for blue colour. Gene is inserted in the b-galactosidase site of the plasmid thereby causing insertional inactivation of the enzyme, so no blue colour is made. [1]</p> <p>b) Plate II - Gene of interest not inserted in the plasmid [0.5] Plate III - No plasmid [0.5]</p>	2
21	<div style="text-align: center;">  <p>The diagram is an inverted pyramid of biomass. At the base is 'Primary producer' (Phytoplankton) with 4 kg/m². Above it is 'Primary consumer' (Zooplankton) with 11 kg/m². The next level is 'Secondary consumer' (Small Fishes) with 25 kg/m². At the top is 'Tertiary consumer' (Large Fishes) with 37 kg/m². The pyramid is inverted, meaning the biomass increases as you move up the trophic levels.</p> <p>Inverted Pyramid of Biomass</p> <p>OR</p> <p>a) Gross Primary Productivity is $45000 + 40367 = 85367 \text{ KJm}^{-2}\text{y}^{-1}$ [1]</p> <p>b) Net production is gradually reducing as we move from producers to consumers due to heat loss/respiration /10% law. [1]</p> </div>	2
Section – C		
22	<p>a) Sperm A [0.5]</p> <p>b) In the figure given, Sperm 'A' has come in contact with the zona pellucida layer (P) of the ovum (Q), it will induce changes in the membrane that will block the entry of additional sperms (B and C). Thus, it ensures that only one sperm can fertilise the ovum. [0.5]</p> <ul style="list-style-type: none"> • The secretions of the acrosome of sperm A will help it to enter into the cytoplasm of the ovum (Q) through the zona pellucid (P) and the plasma membrane, this will induce the completion of the meiotic division of the secondary oocyte (Q). [1] • The second meiotic division in Q being unequal will result in the formation of a second polar body and a haploid ovum. Then, the haploid nucleus of the sperm 'A' and that of the ovum (Q) will fuse together to form a diploid zygote. [1] 	3
23	<p>The embryo with 8 to 16 blastomeres is called a morula.</p> <ul style="list-style-type: none"> • The morula continues to divide and transforms into blastocyst as it moves further into the uterus. • The blastomeres in the blastocyst are arranged into an outer layer called trophoblast and • An inner group of cells attached to trophoblast called the inner cell mass. • The trophoblast layer then gets attached to the endometrium and the inner cell mass gets differentiated as the embryo. • After attachment, the uterine cells divide rapidly and covers the blastocyst. • As a result, the blastocyst becomes embedded in the endometrium of the uterus. This is called implantation and it leads to pregnancy. [0.5X6=3] 	3

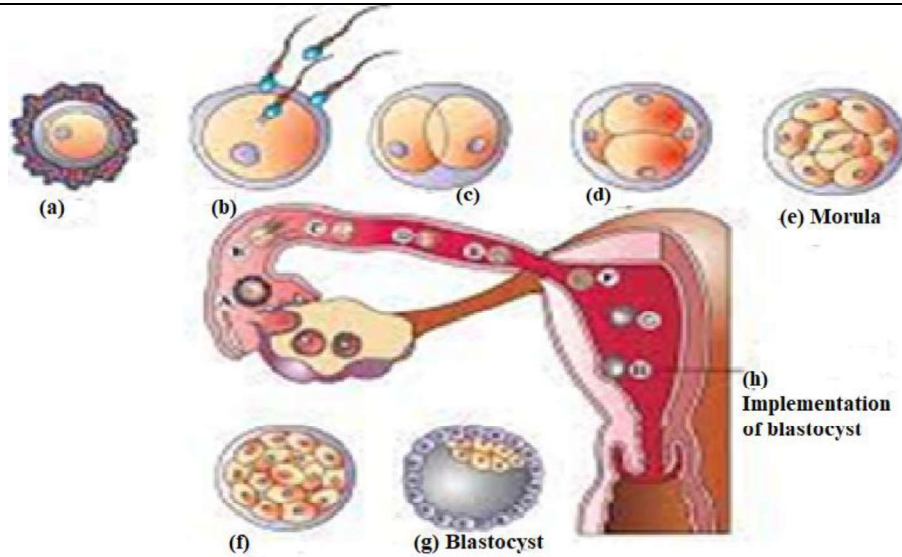

Fig : Fertilisation and passage of growing embryo in fallopian tube

24	<p>a) The embryo has Turner's Syndrome [0.5] due to aneuploidy of the sex chromosome. Such a disorder is caused due to the absence of one of the X chromosomes, i.e., 45 with XO. [0.5]</p> <p>b) She was advised MTP as the child will have the following problems:</p> <ul style="list-style-type: none"> · rudimentary ovaries · poorly developed breasts · lack of other secondary sexual characters · delayed or no onset of the menstrual cycle and infertile. <p style="text-align: right;">[Any 2; 2 marks]</p>	3
25	<p>a) A -stabilising; B - directional; C - disruptive; [1.5]</p> <p>b) Graph A – Stabilising Graph B – Directional Graph C – Disruptive</p> <p style="text-align: right;">[1.5]</p>	3
26	<ul style="list-style-type: none"> • It will adversely affect the secondary treatment or biological treatment of sewage. • When the aeration tank is not functional, the air will not be pumped into it. • This will not allow the vigorous growth of useful aerobic microbes into flocs (masses of bacteria associated with fungal filaments to form mesh like structures). • Thus, the major part of the organic matter in the effluent will not be consumed by these bacteria. • The BOD (biochemical oxygen demand) of the effluent will not be reduced. BOD refers to the amount of the oxygen that would be consumed if all the organic matter in one liter of water were oxidised by bacteria. 	3

	<ul style="list-style-type: none"> The greater the BOD of waste water, more is its polluting potential. Thus, the effluent will remain polluted with high amount of organic matter and high BOD. [0.5X6=3] 	
27	<p>a) <i>Cry I Ab</i> [0.5]</p> <p>b) The spores of Bt contain crystalline toxin which is inactive [0.5]; for this crystalline toxin protein to become active it needs alkaline pH, which is present in insect gut [0.5] The gut lining is broken down/mid gut epithelial cells become porous/swollen/cell lysis. [0.5]</p> <p>c) The Bt-toxin gene is cloned and inserted into the plant genome by recombinant DNA technology. These genetically modified (GM) plants express the Bt-toxin genes and become pest-resistant. [1]</p> <p style="text-align: center;">OR</p> <p>a) (i) Functional enzyme lipase is given to the patient by injection. [0.5] (ii) This procedure is not completely curative. [0.5]</p> <p>b)</p> <ul style="list-style-type: none"> The disease can be treated by using Gene therapy. [0.5] Gene therapy is a collection of methods that allows correction of a gene defect that has been diagnosed in a child/embryo. [0.5] Here genes are inserted into a person's cells and tissues to treat a disease. Correction of a genetic defect involves delivery of a normal gene into the individual or embryo to take over the function of and compensate for the non-functional gene. [1] 	3
28	<p>Prokaryotic organisms' diversity is not given any figures by ecologist because of following reasons.</p> <ul style="list-style-type: none"> Classification and identification of vast diversity of microbes is very difficult and cannot be efficiently done with use of currently available methods. For many microorganisms, it is difficult to culture them under laboratory condition. According to current biochemical and molecular techniques, it is estimated that microbes diversity can range in billions with microbes inhabiting diverse habitat on earth, with enormous diversity present in air, water and soil. Hence, more advanced molecular and biochemical techniques are needed to classify and identify this enormous diversity of microbes. 	3
Section – D		
29	<p>a) Plasmids which can be used to insert the gene of interest from a desired organism into a host/ they act as vectors to transfer gene of interest into the host. [1]</p> <p style="text-align: center;">OR</p> <p>Ori- Origin of replication (ori) - No replication will take place resulting in no copies of linked DNA.</p> <p>b) i) 5'... ATC GTA/AAG CTT /CAT...3' 3'... TAG CAT/TTC GAA /GTA...5' [1 mark for both strand]</p> <p style="text-align: center;">OR</p> <p>5'... AAG CTT ...3' 3'... TTC GAA ...5' [1 mark for both strand]</p> <p>ii) No, as the restriction enzymes need to be the same which cut the DNA of the plasmid and the gene of interest from the plant. [0.5+0.5=1]</p> <p>c) PUC18 as it has a higher copyrate. [0.5+0.5=1]</p>	4
30	<p>a) <i>P. aurelia</i> species is competitively superior <i>P. aurelia</i> grows in numbers more quickly than <i>P.</i></p>	4

	<p><i>caudatum</i> and shows more individuals in the same volume of culture/ 100 <i>Paramecia aurelia</i> in 6 days whereas 60 <i>P. caudatum</i> in 8 days. [2]</p> <p>b) <i>Competitive Exclusion Principle</i> which states that two closely related species competing for the same resources cannot co-exist indefinitely and the competitively inferior one will be eliminated. G.F. Gause, [1]</p> <p>c) One such mechanism is 'resource partitioning'. If two species compete for the same resource, they could avoid competition by choosing different times for feeding or different foraging patterns, to avoid competition and co-exist due to behavioural differences in their foraging activities. [1]</p> <p style="text-align: center;">OR</p> <p>Graph A - As both species grow simultaneously.</p>	
--	--	--

Section-E

31	<p>Couple 1: Normal reports of female, Normal sperms in testes, Missing connection in epididymis and Vas deferens in male.</p> <p>Assisted Reproductive Technology: Semen will be devoid of sperms in this case. So, In-vitro fertilization (IVF) by collecting the sperms from epididymis, followed by ZIFT or IUT (Test Tube Baby) is suggested. ZIFT is transfer of zygote or early embryo up to 8 blastomeres in fallopian tube and IUT refers to transfer of embryos with more than 8 blastomeres in uterus. [1]</p> <p>Couple 2: Blockage in the fallopian tube in the female, Normal reports of male.</p> <p>Assisted reproductive Technology: Blockage of Fallopian Tube will not allow transfer of sperms to the site of fertilisation. In-vitro fertilization (IVF) followed by IUT (Test Tube Baby). It would involve transfer of embryo with more than 8 blastomeres in uterus. [1]</p> <p>Couple 3: Normal reports of female, Poor semen parameters in terms of count, motility and morphology in male partner</p> <p>Assisted Reproductive Technology: Intracytoplasmic sperm injection (ICSI) in which sperm is directly injected into the ovum. Artificial insemination procedure is used mainly when sperms have poor characteristic or low sperm count. [1]</p> <p>Couple 4: Low ovarian reserve in female, Normal reports in male</p> <p>Assisted Reproductive Technology: In-vitro-fertilization (IVF) by selection of normal blastocysts from ovary followed by Zygote intra-fallopian transfer involving transfer of zygote or early embryos up to 8 blastomeres (ZIFT) or transfer of embryo with more than 8 blastomeres in the uterus (IUT). [1]</p> <p>Couple 5: Poor ovarian reserve in female, morphologically abnormal sperms in male partner.</p> <p>Assisted Reproductive Technology: ICSI intracytoplasmic sperm injection in which selected normal sperms will be injected into the selected blastocyst. Intracytoplasmic sperm injection (ICSI) procedure is used mainly when sperms have poor characteristic or low sperm count. [1]</p> <p style="text-align: center;">OR</p>	5
----	--	---

Situation No.	Requirement of contraceptive for-	Name of contraceptive device	Mode of action
---------------	-----------------------------------	------------------------------	----------------

	1	blocking the entry of sperms through cervix	Diaphragms/ cervical caps/ vaults	Cover the cervix during coitus	
	2	spacing between children	Cu or hormone releasing IUDs such as Cu T/Cu7/ Multiload 375/ Progestasert/LNG 20	Cu ions from Cu containing IUDs increase phagocytosis of sperms within uterus, suppress sperm motility and fertilizing capacity/ hormone releasing IUDs make uterus unsuitable for implantation	
	3	effective emergency contraceptive	Pills containing Progestogens or progestogen-estrogen combination or IUDs within 72 hours of coitus	Pills inhibit ovulation and implantation as well as alter the quality of cervical mucus to prevent the entry of sperms/IUDs - Cu ions increase phagocytosis of sperms within uterus, suppress sperm motility and fertilizing capacity/ hormone releasing IUDs make uterus unsuitable for implantation	
	4	terminal method to prevent any more pregnancy in female	Tubectomy	Block gamete transport and prevent conception.	
	5	sterilization in male	Vasectomy	Blocks sperm transport.	
	[0.5 X 10 =5]				

32	<p>5'--ATG ACC GTA TTT TCT GTA GTG CCC GTA CTT CAG GCA TAA---3'= CODING</p> <p>a) 3'- TAC TGG CAT AAA AGA CAT CAC GGG CAT GAA GTC CGT ATT---5'= TEMPLATE [1 mark]</p> <p>5'---AUG ACC GUA UUU UCU GUA GUG CCC GUA CUU CAG GCA UAA---3' [1 mark]</p> <p>b) i. <u>In a bacterium</u> 5'---AUG ACC GUA UUU UCU GUA GUG CCC GUA CUU CAG GCA UAA---3' [1 mark]</p> <p>ii. <u>In humans</u> 5'---mGpppAUG ACC UUU UCU GUG CCC CUU CAG GCA UAA- Poly A tail--3' [1 mark]</p> <p>c) 9 amino acids in the polypeptide because UAA is stop/terminator codon and does not code for any amino acid. [1 mark]</p> <p style="text-align: center;">OR</p> <p>a) Codominance [0.5]</p> <p>b) Codominance is a condition in which two different alleles for a genetic trait are expressed. Individuals receive one version of a gene, called an allele, from each parent. [0.5]</p> <p>c) i) If pure breeding red coated cattles are represented as 'RR' and pure breeding white coated as 'rr'. If Red is dominant over White. A cross between 'RR' and 'rr' would produce red coated cattles (RR) and white coated cattle (rr) in the ratio of 3: 1</p>	5
----	---	---

Parents: RR (Red) X rr (White)

Gametes: R r

	R	r
R	RR Red coat	Rr Redcoat
r	Rr Red coat	rr White coat

F1 generation- 3:1

[2]

- ii) If the red and white coated cattles produce pink colour on a cross then, they exhibit incomplete dominance in the inheritance of coat colour due to which they produce pink coloured coat upon hybridisation.

If pure breeding red coated cattles are represented as 'RR' and pure breeding white coated as 'rr', then the pink coated cattles are 'Rr'.

A cross between 'RR' and 'rr' would produce pink coated cattles (Rr) and white coated cattle (rr) in the ratio of 1 :2: 1

Parents: RR (Red) X rr (White)

Gametes: R W

	R	r
R	RR Red coat	Rr Pink coat
r	Rr Pink coat	rr (White)

F1 Generation- 1:2:1

[2]

33

- **Lymphoid organs:** These are the organs where origin and/or maturation and proliferation of lymphocytes occur.
- **The primary lymphoid organs** are bone marrow and thymus where immature lymphocytes differentiate into antigen-sensitive lymphocytes.
- After maturation the lymphocytes migrate to **secondary lymphoid organs** like spleen, lymph nodes, tonsils, Peyer's patches of small intestine and appendix.
- The **secondary lymphoid organs** provide the sites for interaction of lymphocytes with the antigen, which then proliferate to become effector cells.
- The **bone marrow** is the main lymphoid organ where all blood cells including lymphocytes are produced.
- The **thymus** is a lobed organ located near the heart and beneath the breastbone.
- Both **bone-marrow and thymus** provide micro-environments for the development and maturation of T-lymphocytes.
- The **spleen** is a large bean - shaped organ. It mainly contains lymphocytes and phagocytes.
- It acts as a filter of the blood by trapping blood-borne micro - organisms. Spleen also has a large reservoir of erythrocytes.

5

- The **lymph nodes** are small solid structures located at different points along the lymphatic system. Lymph nodes serve to trap the micro-organisms or other antigens, which happen to get into the lymph and tissue fluid. Antigens trapped in the lymph nodes are responsible for the activation of lymphocytes present there and cause the immune response.

There is lymphoid tissue also located within the lining of the major tracts (respiratory, digestive and urogenital tracts) called mucosa - associated lymphoid tissue (**MALT**). It constitutes about 50 per cent of the lymphoid tissue in human body. [0.5 × 10 =5]

OR

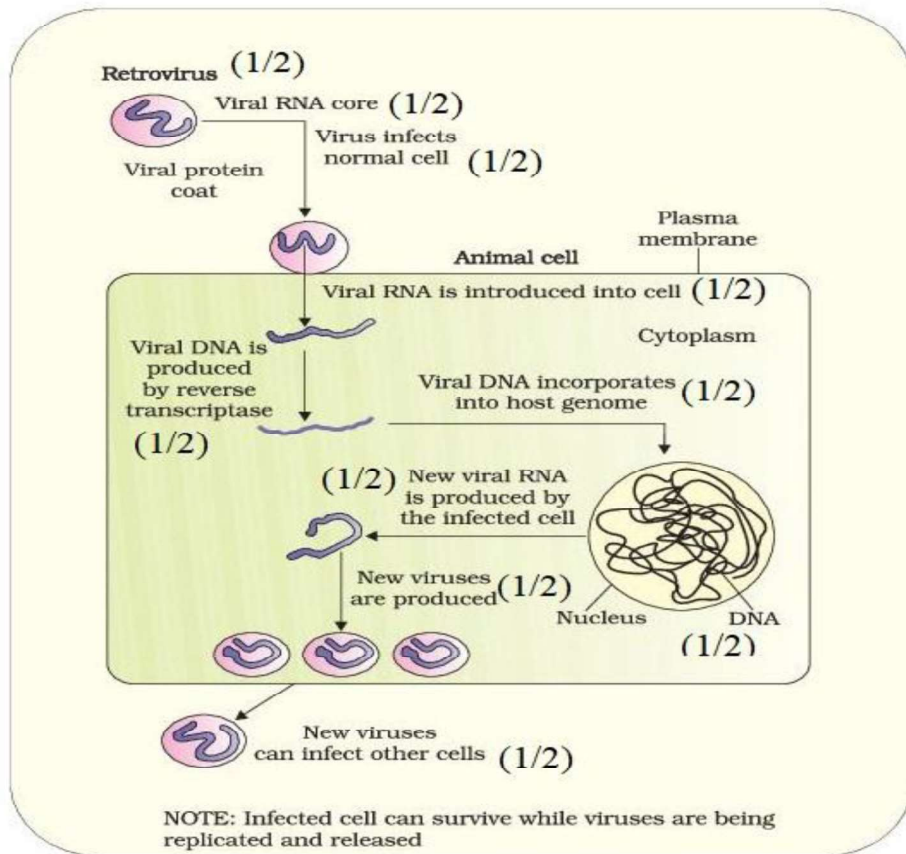

Figure Replication of retrovirus

Sample Question Paper 2023-24

Class XII

Biology (Subject Code-044)

Maximum Marks: 70

Time: 3 hours

General Instructions:

- (i) All questions are compulsory.
- (ii) The question paper has five sections and 33 questions. All questions are compulsory.
- (iii) Section–A has 16 questions of 1 mark each; Section–B has 5 questions of 2 marks each; Section– C has 7 questions of 3 marks each; Section– D has 2 case-based questions of 4 marks each; and Section–E has 3 questions of 5 marks each.
- (iv) There is no overall choice. However, internal choices have been provided in some questions. A student has to attempt only one of the alternatives in such questions.
- (v) Wherever necessary, neat and properly labeled diagrams should be drawn.

Section - A

Q.No.	Question	Marks																				
1	Remnants of nucellus are persistent during seed development in: a) pea b) groundnut c) wheat d) black pepper	1																				
2	The wall layer of microsporangium which nourishes the pollen grain is: a) epidermis b) endothecium c) middle layers d) tapetum	1																				
3	A short piece of DNA, having 20 base pairs, was analyzed to find the number of nucleotide bases in each of the polynucleotide strands. Some of the results are shown in the table. <table border="1" data-bbox="485 1541 1218 1696"><thead><tr><th></th><th colspan="4">Number of nucleotide bases</th></tr><tr><th></th><th>Adenine</th><th>Cytosine</th><th>Guanine</th><th>Thymine</th></tr></thead><tbody><tr><th>Strand 1</th><td>4</td><td>4</td><td></td><td></td></tr><tr><th>Strand 2</th><td></td><td>5</td><td></td><td></td></tr></tbody></table> How many nucleotides containing Adenine were present in strand 2? a) 2 b) 4 c) 5 d) 7		Number of nucleotide bases					Adenine	Cytosine	Guanine	Thymine	Strand 1	4	4			Strand 2		5			1
	Number of nucleotide bases																					
	Adenine	Cytosine	Guanine	Thymine																		
Strand 1	4	4																				
Strand 2		5																				

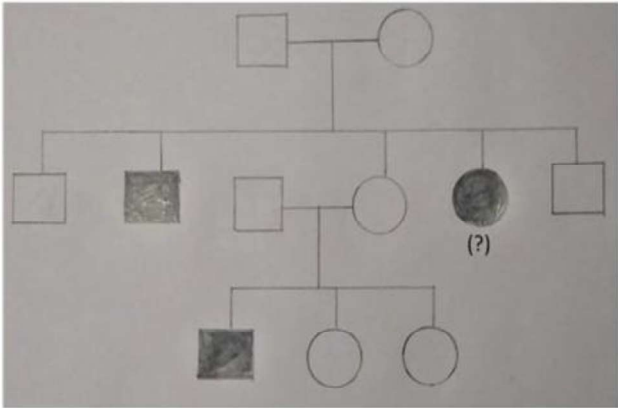
4	<p>In a certain species of insects, some have 13 chromosomes, and the others have 14 chromosomes. The 13 and 14 chromosome bearing organisms are</p> <p>a) males and females, respectively b) females and males, respectively c) all males d) all females</p>	
5	<p>At a particular locus, the frequency of allele A is 0.8 and that of allele a is 0.2. What would be the frequency of heterozygotes in a random mating population at equilibrium?</p> <p>a) 0.32 b) 0.16 c) 0.24 d) 0.48</p>	
6	<p>Variations caused due to mutations are</p> <p>a) random and directionless b) random and directional c) random and small d) random, small and directional</p>	
7	<p>What is the smallest part of a DNA molecule that can be changed by a point mutation?</p> <p>a) Oligonucleotide b) Codon c) Gene d) Nucleotide</p>	
8	<p>What should be the genotype of the indicated member?</p>  <p>a) AA b) Aa c) XY d) aa</p>	

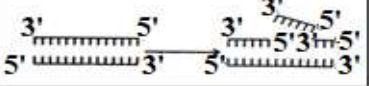
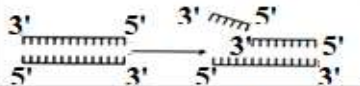
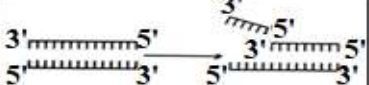
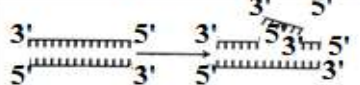
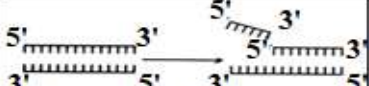
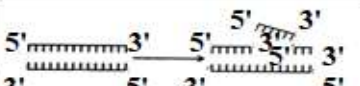
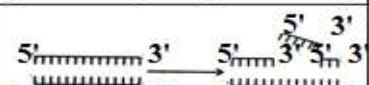
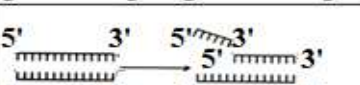
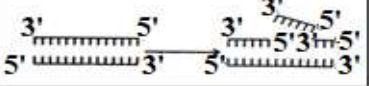
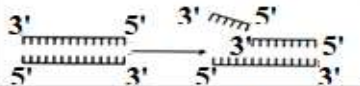
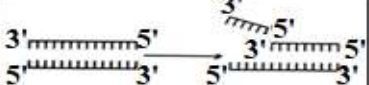
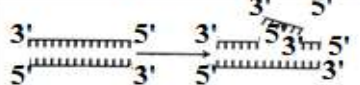
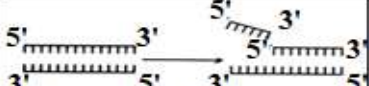
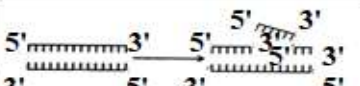
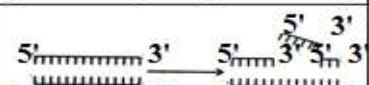
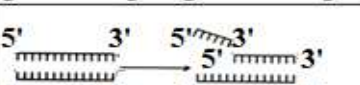
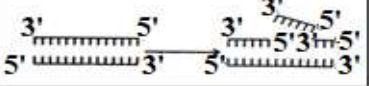
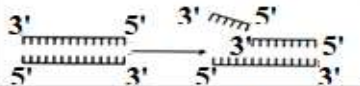
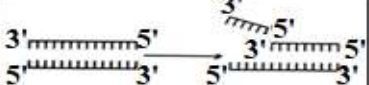
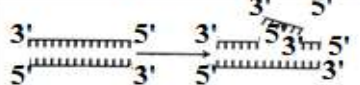
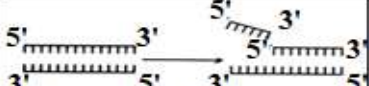
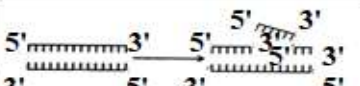
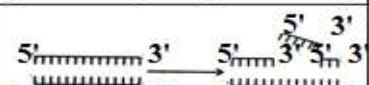
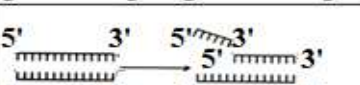
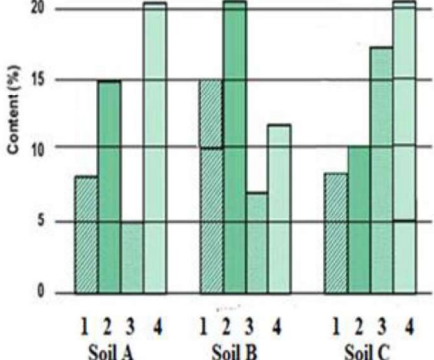
9	<p>A patient was advised to have a kidney transplant. To suppress the immune reaction, the doctor would administer him:</p> <ol style="list-style-type: none"> statins produced from <i>Monascus purpureus</i> statins produced from <i>Streptococcus thermophilus</i> cyclosporin A produced from <i>Trichoderma polysporum</i> cyclosporin A produced from <i>Clostridium butylicum</i> 	1															
10	<p>Identify the activity of endonuclease and exonuclease in the given image.</p> <table border="1" data-bbox="264 447 1068 940"> <thead> <tr> <th></th> <th>Endonuclease</th> <th>Exonuclease</th> </tr> </thead> <tbody> <tr> <td>a)</td> <td></td> <td></td> </tr> <tr> <td>b)</td> <td></td> <td></td> </tr> <tr> <td>c)</td> <td></td> <td></td> </tr> <tr> <td>d)</td> <td></td> <td></td> </tr> </tbody> </table>		Endonuclease	Exonuclease	a)			b)			c)			d)			1
	Endonuclease	Exonuclease															
a)																	
b)																	
c)																	
d)																	
11	<p>The main objective of production of pest resistant GM crops is to</p> <ol style="list-style-type: none"> encourage eco-friendly pesticides reduce pesticide accumulation in food chain eliminate pests from the field without the use of manual labour retain maximum nutritional content in the crop that would be otherwise consumed by pest 	1															
12	<p>Observe the contents 1,2,3 and 4 of soil samples A,B and C shown in the graph. If the temperature and soil moisture of all soil samples are identical, which soil sample (s) will show faster decomposition?</p>  <p>1 indicates lignin content, 2 indicates chitin, 3 indicates Nitrogen content and 4 indicates sugar content</p>	1															

	a) Soil Sample A b) Soil Sample B c) Soil Samples A and B both d) Soil Sample C	
--	--	--

Question No. 13 to 16 consist of two statements – Assertion (A) and Reason (R). Answer these questions selecting the appropriate option given below:

- a) Both A and R are true and R is the correct explanation of A.
- b) Both A and R are true and R is not the correct explanation of A.
- c) A is true but R is false.
- d) A is false but R is true.

13	Assertion: Primary endosperm nucleus is diploid. Reason: It is the product of double fertilisation.	1
14	Assertion: Ribosomal RNA is synthesized in the nucleus of the cell. Reason: It is translated with the enzyme RNA polymerase III.	1
15	Assertion: Smoking can raise blood pressure and increase heart rate. Reason: Nicotine stimulates adrenal glands to release adrenaline and nor-adrenaline into the blood circulation, both of which raise blood pressure and increase heart rate.	1
16	Assertion: PCR is a powerful technique to identify genetic disorders. Reason: PCR can detect mutations in low amounts of DNA.	1

Section - B

17	Explain the process of hormonal regulation of spermatogenesis.	2																																								
18	<p>The diagram below shows the sequence of amino acids in part of a haemoglobin molecule.</p> <div style="text-align: center;"> <table style="border-collapse: collapse; margin: auto;"> <tr> <td style="padding: 5px;">Val</td> <td style="padding: 5px;">His</td> <td style="padding: 5px;">Leu</td> <td style="padding: 5px;">Thr</td> <td style="padding: 5px;">Pro</td> <td style="padding: 5px;">Glu</td> <td style="padding: 5px;">Glu</td> <td style="padding: 5px;">haemoglobin chain</td> </tr> <tr> <td colspan="7" style="border-top: 1px solid black; border-bottom: 1px solid black;"></td> <td></td> </tr> <tr> <td style="padding: 5px;"> </td> <td style="padding: 5px;"> </td> <td style="padding: 5px;"> </td> <td style="padding: 5px;"> </td> <td style="padding: 5px;"> </td> <td style="padding: 5px;"> </td> <td style="padding: 5px;"> </td> <td style="padding: 5px;">mRNA</td> </tr> <tr> <td colspan="7" style="border-top: 1px solid black; border-bottom: 1px solid black;"></td> <td></td> </tr> <tr> <td style="padding: 5px;">CAT</td> <td style="padding: 5px;">GTA</td> <td style="padding: 5px;">AAT</td> <td style="padding: 5px;">TGA</td> <td style="padding: 5px;">GGA</td> <td style="padding: 5px;">* CTT</td> <td style="padding: 5px;">CTC</td> <td style="padding: 5px;">DNA</td> </tr> </table> <p>Key: Val = valine Thr = threonine His = histidine Pro = proline Leu = leucine Glu = glutamic acid</p> </div>	Val	His	Leu	Thr	Pro	Glu	Glu	haemoglobin chain																mRNA									CAT	GTA	AAT	TGA	GGA	* CTT	CTC	DNA	2
Val	His	Leu	Thr	Pro	Glu	Glu	haemoglobin chain																																			
							mRNA																																			
CAT	GTA	AAT	TGA	GGA	* CTT	CTC	DNA																																			

- a) If the base T* was substituted with A, how would it affect the haemoglobin chain?
- b) Name the condition and the effects associated with the above substitution.

19 The graph given below indicates the administration of the first (L) and second dose (M) of a vaccine. The corresponding response of the body is indicated by X and Y. Interpret the graph and explain the reason for such a response shown by the body.

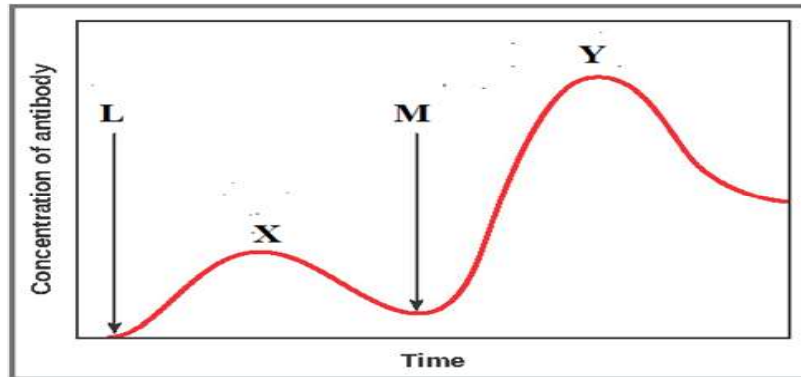

20 The image below shows the result of plating bacteria in chromogenic medium after incorporating the gene of interest in plasmid. Some plates had blue colonies; some plates had white colonies. A single bacterium extracted from Plate I,II,III is shown below:

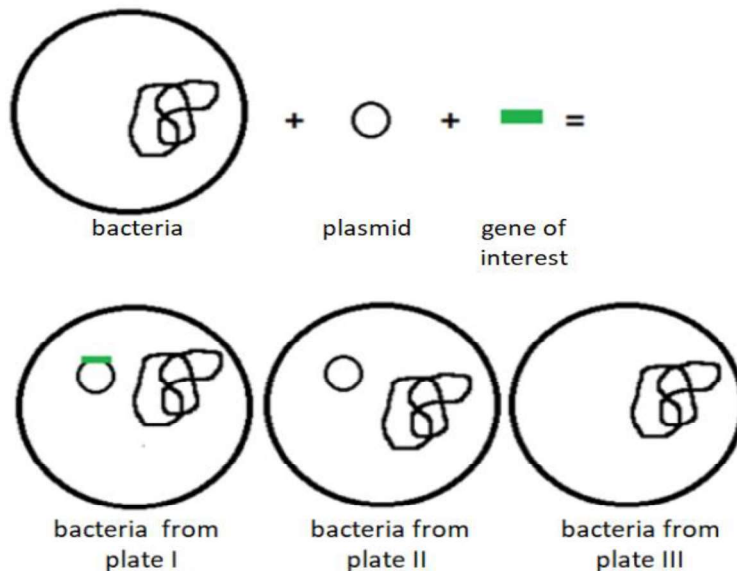

On the basis of your observations

- a) Identify the plate(s) which is/are white. Give a reason.
- b) Identify the plate(s) which is/are blue. Give a reason.

21

Biomass of a standing crop of phytoplankton is 4 kg/m^2 which supports a large standing crop of zooplankton having a biomass 11 kg/m^2 . This is consumed by small fishes having biomass 25 kg/m^2 which are then consumed by large fishes with the biomass 37 kg/m^2 .

Draw an ecological pyramid indicating the biomass at each stage and also name the trophic levels. Mention whether it is an upright or inverted pyramid.

OR

Use the information provided in the table given below to answer the following questions:

Tropic level	Net Production($\text{KJm}^{-2}\text{y}^{-1}$)	Respiration ($\text{KJm}^{-2}\text{y}^{-1}$)
Top Carnivore	50	35
Carnivores	420	378
Herbivores	4490	4041
Producers	45000	40,367

- Calculate the gross primary productivity.
- Analyze the trend in the Net Production from Producers to Top Carnivore. Give a reason for your observation.

2

Section - C

22

The figure given below shows 3 sperms A, B and C.

- Which one of the three sperms will gain entry into the ovum?
- Describe the associated changes induced by it on P and Q.

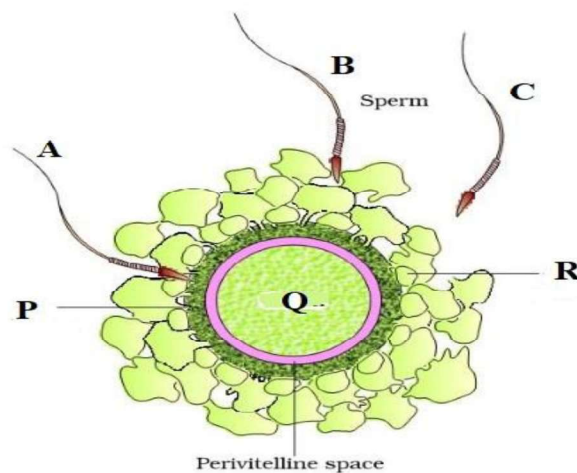
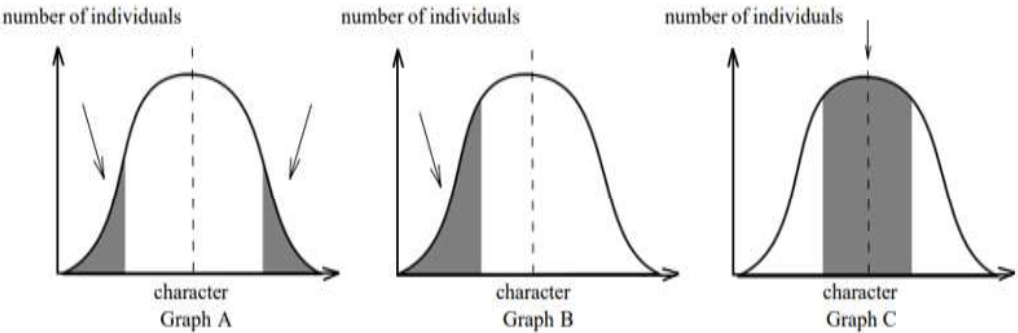

Figure . . . Ovum surrounded by few sperms

3

23	Explain the phases in embryonic development from the morula stage till the establishment of pregnancy in a human female.	3
24	<p>A pregnant human female was advised to undergo MTP. It was diagnosed that the fetus she was carrying had developed from a zygote having 45 chromosomes with only one X chromosome.</p> <p>a) What is this condition called and how does it arise?</p> <p>b) Why was she advised to undergo MTP?</p>	3
25	<p>The graphs below show three types of natural selection. The shaded areas marked with arrows show the individuals in the population which are not selected. The dotted vertical lines show the statistical means.</p>  <p>number of individuals</p> <p>number of individuals</p> <p>number of individuals</p> <p>character Graph A</p> <p>character Graph B</p> <p>character Graph C</p> <p>a) What names are given to the types of selection shown in graphs A, B and C.</p> <p>b) After the selection has operated for several generations in the above populations indicated as Graph A, B and C, graphically illustrate the probable results.</p>	3
26	The aeration tank of a sewage treatment plant is not functioning properly. Explain in detail the impact of this on the treatment of sewage and BOD of the effluent.	3
27	<p>A farmer grew 2 varieties of corn crop in field A and B. He grew normal corn crops in field A and GM corn crops in field B. He observed corn borers attacked only in field A. To control it, spores of Bt were sprayed in field A.</p> <p>a) Name the gene in the spores responsible for the control of this pest.</p> <p>b) What effect will the spores of Bt have on the insect pest?</p> <p>c) How has field B developed resistance against this pest?</p> <p style="text-align: center;">OR</p> <p>Lipoprotein lipase deficiency (LPLD) is a genetic disorder in which a person has a defective gene for lipase. This leads to high triglycerides, stomach pain, fat deposits under the skin. It may eventually affect the liver, pancreas and may also cause diabetes. The disorder occurs if a child acquires defective genes from both</p>	3

	<p>parents (autosomal recessive). ERT (enzyme replacement treatment) is one of the treatments offered to patients with LPLD.</p> <p>a) (i) What procedure is followed in ERT? (ii) What could be one possible drawback of ERT?</p> <p>b) How can LPLD be treated using Biotechnology? Elaborate.</p>	
28	Give three reasons as to why the prokaryotes are not given any figures for their diversity by the ecologists.	3

Section - D

Q. No. 29 and 30 are case-based questions. Each question has 3 subparts with internal choice in one subpart.

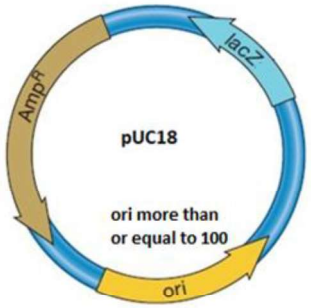
29	<p>The structure below shows pUC18 which is similar to pBR322 in its function. However, they differ in some of their restriction sites and number of <i>ori</i>. The <i>ori</i> number for pBR322 is approximately 20.</p> <div style="text-align: center;">  </div> <p>a) How are puc18 and pBR322 used in biotechnological studies?</p> <p style="text-align: center;">OR</p> <p>What will be the impact if <i>ori</i> in the above structure gets damaged?</p> <p>b) The <i>lac z</i> gene has many recognition sites. Study the segment of DNA given below and answer the questions</p> <p>5'... ATC GTA AAG CTT CAT...3'</p> <p>3'... TAG CAT TTC GAA GTA...5'</p> <p>i) Applying your knowledge of palindrome sequences identify and mark the possible region where the restriction enzyme X will act.</p> <p>ii) Restriction enzyme Y was used to extract gene of interest from a plant. This gene needs to be inserted in the given DNA segment which has been treated with restriction enzyme X. Will there be a successful recombination? Explain with a reason.</p> <p>c) Which one of the two (pUC18 and pBR322) would you prefer for biotechnological studies? Justify.</p>	4
----	---	---

30

Observe the graph given below.

4

The graph represents inter-specific interaction between two species of *Paramecia* competing for the same resource in a culture medium. *Paramecium caudatum* and *Paramecium aurelia* were grown in separate cultures as well as in mixed cultures. It was found that each species grew in numbers according to the logistic equation.

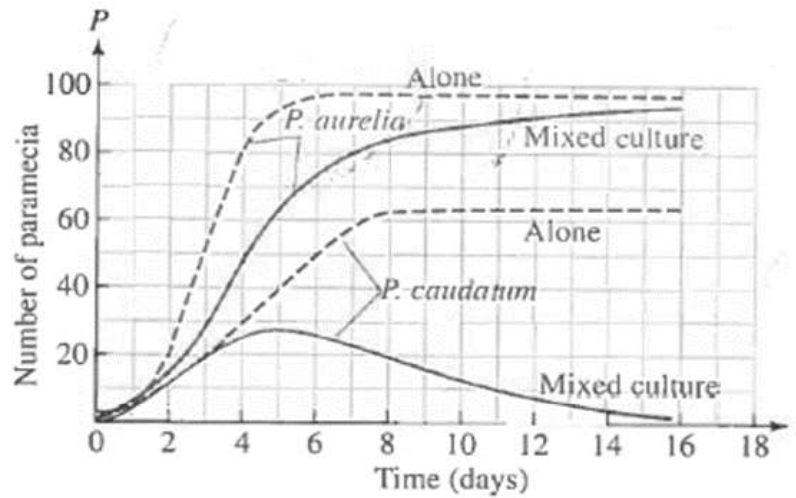

- Which species is competitively superior? Support it with the data provided in the graph.
- State the underlying principle for the above result and name the scientist associated with this principle.
- Explain the mechanism in which two or more species competing with each other can co - exist.

OR

Graphs A and B shown below depict interaction of two species. Which graph indicates Mutualism? Give reason.

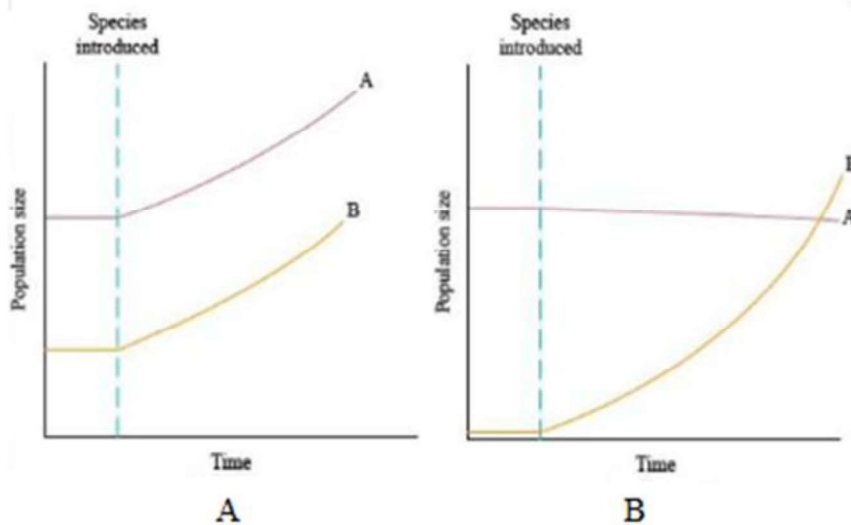

Section - E

31

Placed below are case studies of some couples who were not able to have kids. These couples are not ready for adoption or taking gametes from donors. After thoroughly examining the cases, which Assisted Reproductive Technology will you suggest to these couples as a medical expert? Explain briefly with justification of each case.

5

Couple	Test reports of Female partner	Test reports of male partner
Couple 1	Normal reports	Normal sperms in testes, Missing connection in epididymis and Vas deferens
Couple 2	Blockage in the fallopian tube	Normal reports
Couple 3	Normal reports	Poor semen parameters in terms of count, motility and morphology
Couple 4	low ovarian reserve	Normal reports
Couple 5	Sterilization in male	Morphologically abnormal sperms

OR

Given below are certain situations. Analyse the situation and suggest the name of suitable contraceptive device along with mode of action.

Situation	Requirement of contraceptive for -	Name of contraceptive device	Mode of action
1	blocking the entry of sperms through cervix		
2	spacing between children		
3	effective emergency contraceptive		
4	terminal method to prevent any more pregnancy in female		
5	sterilization in male		

32	<p>Given below is a stretch of DNA showing the coding strand of a structural gene of a transcription unit?</p> <p>5'--ATG ACC GTA TTT TCT GTA GTG CCC GTA CTT CAG GCA TAA—3'</p> <p>a) Write the corresponding template strand and the mRNA strand that will be transcribed, along with its polarity.</p> <p>b) If GUA of the transcribed mRNA is an intron, depict the sequence involved in the formation of mRNA /the mature processed hnRNA strand.</p> <p>i. In a bacterium</p> <p>ii. In humans</p> <p>c) Upon translation, how many amino acids will the resulting polypeptide have? Justify.</p> <p style="text-align: center;">OR</p> <p>In shorthorn cattle, the coat colours red or white are controlled by a single pair of alleles. A calf which receives the allele for red coat from its mother and the allele for white coat from its father is called a 'roan'. It has an equal number of red and white hairs in its coat.</p> <p>a) Is this an example of codominance or of incomplete dominance?</p> <p>b) Give a reason for your answer.</p> <p>c) With the help of genetic cross explain what will be the consequent phenotype of the calf when</p> <p>i. red is dominant over white</p> <p>ii. red is incompletely dominant.</p>	5
33	<p>Explain the role of Primary and Secondary Lymphoid organs with the help of suitable examples.</p> <p style="text-align: center;">OR</p> <p>With the help of a flow chart illustrate how an infected animal cell can survive while viruses are being replicated or released.</p>	5
